



This is a digital copy of a book that was preserved for generations on library shelves before it was carefully scanned by Google as part of a project to make the world's books discoverable online.

It has survived long enough for the copyright to expire and the book to enter the public domain. A public domain book is one that was never subject to copyright or whose legal copyright term has expired. Whether a book is in the public domain may vary country to country. Public domain books are our gateways to the past, representing a wealth of history, culture and knowledge that's often difficult to discover.

Marks, notations and other marginalia present in the original volume will appear in this file - a reminder of this book's long journey from the publisher to a library and finally to you.

Usage guidelines

Google is proud to partner with libraries to digitize public domain materials and make them widely accessible. Public domain books belong to the public and we are merely their custodians. Nevertheless, this work is expensive, so in order to keep providing this resource, we have taken steps to prevent abuse by commercial parties, including placing technical restrictions on automated querying.

We also ask that you:

- + *Make non-commercial use of the files* We designed Google Book Search for use by individuals, and we request that you use these files for personal, non-commercial purposes.
- + *Refrain from automated querying* Do not send automated queries of any sort to Google's system: If you are conducting research on machine translation, optical character recognition or other areas where access to a large amount of text is helpful, please contact us. We encourage the use of public domain materials for these purposes and may be able to help.
- + *Maintain attribution* The Google "watermark" you see on each file is essential for informing people about this project and helping them find additional materials through Google Book Search. Please do not remove it.
- + *Keep it legal* Whatever your use, remember that you are responsible for ensuring that what you are doing is legal. Do not assume that just because we believe a book is in the public domain for users in the United States, that the work is also in the public domain for users in other countries. Whether a book is still in copyright varies from country to country, and we can't offer guidance on whether any specific use of any specific book is allowed. Please do not assume that a book's appearance in Google Book Search means it can be used in any manner anywhere in the world. Copyright infringement liability can be quite severe.

About Google Book Search

Google's mission is to organize the world's information and to make it universally accessible and useful. Google Book Search helps readers discover the world's books while helping authors and publishers reach new audiences. You can search through the full text of this book on the web at <http://books.google.com/>

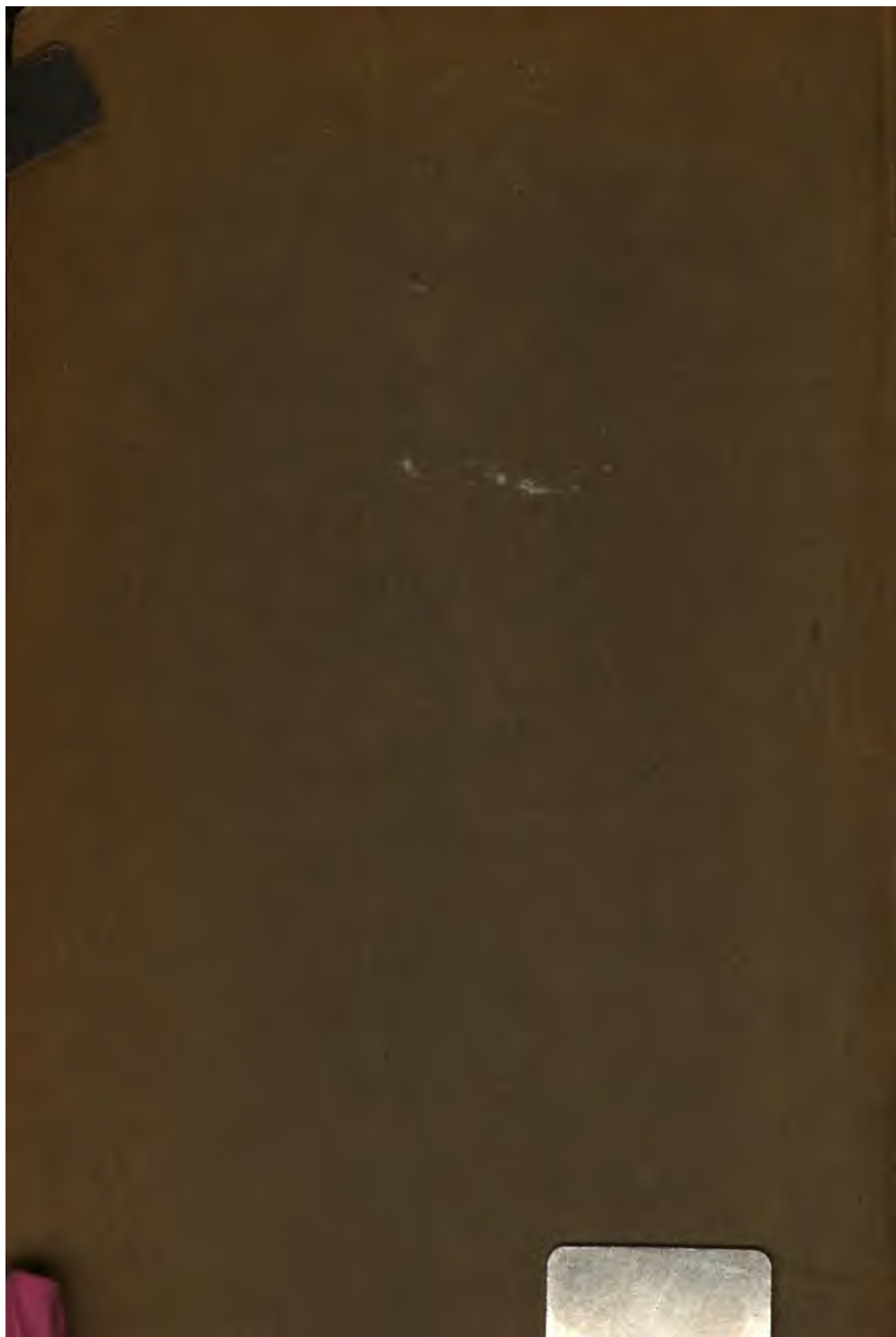



4 1914

Lewis P. McGilvary
Elect. Eng. 1916

PRESENTED FROM
THE LIBRARY OF

Lewis P. McGilvary
Elect. Eng. 1916
1902 Arlington Place
MADISON, WIS.

Lewis P. McGilvary
Elect. Eng. 1916

STRENGTH OF MATERIALS

Lewis P. McGilvar
Elect. Eng. 1916

McGraw-Hill Book Company

Publishers of Books for

Electrical World	The Engineering and Mining Journal
Engineering Record	Engineering News
Railway Age Gazette	American Machinist
Signal Engineer	American Engineer
Electric Railway Journal	Coal Age
Metallurgical and Chemical Engineering	Power

STRENGTH OF MATERIALS

BY

JAMES E. BOYD, M.S.

Professor of Mechanics, The Ohio State University.

FIRST EDITION

THIRD IMPRESSION, CORRECTED

McGRAW-HILL BOOK COMPANY, INC.

239 WEST 39TH STREET, NEW YORK

6 BOUVERIE STREET, LONDON, E. C.

1911

COPYRIGHT, 1911,
BY
McGRAW-HILL BOOK COMPANY

Stanbope Press
F. H. GILSON COMPANY
BOSTON, U.S.A.

252246
JAN 23 1922

1373403

SDH
.B694
19 11

PREFACE.

THIS book is intended to give the student a grasp of the physical and mathematical ideas underlying the Mechanics of Materials, together with enough of the experimental facts and simple applications to sustain his interest, fix his theory, and prepare him for the technical subjects as given in works on Machine Design, Reinforced Concrete, or Stresses in Structures.

It is assumed that the reader has completed the Integral Calculus, and has taken a course in Theoretical Mechanics which includes statics and the moment of inertia of plane areas. Chapters XVI and XVII give a brief discussion of center of gravity and moment of inertia. Students who have not mastered these subjects should study these chapters before taking up Chapter V (preferably before beginning Chapter I).

The problems, which are given with nearly every article, form an essential part of the development of the subject. They were prepared with the twofold object of fixing the theory and enabling the student to discover for himself important facts and applications. The first problems of each set usually require the use of but one new principle, — the one given in the text which immediately precedes; the later problems aim to combine this principle with others previously studied and with the fundamental operations of Mathematics and Mechanics. The constants given in the data or derived from the results of the problems fall within the range of the figures obtained from actual tests of materials. Many of the problems are taken directly from such measurements. Some of them are from tests made by the author or his colleagues at the Ohio State University; others are from bulletins of the University of Illinois Engineering Experiment Station, from "Tests of Metals" at the Watertown Arsenal, and from the Transactions of the American Society of Civil Engineers.

This book is designed for use with "Cambria Steel," to which references are made by title instead of by page, so that they are adapted to any edition of the handbook.

The author acknowledges his indebtedness for suggestions and criticisms to Professors C. T. Morris, E. F. Coddington, Robert Meiklejohn, K. D. Swartzel, and many others of the Faculty of the College of Engineering; and to Professor Horace Judd of the Department of Mechanical Engineering for the material for several of the half-tones. He also expresses his obligations to the books which have helped to mold his ideas of the subject, — Johnson's "Materials of Construction," Ewing's "Strength of Materials," and especially the textbooks which he has used with his classes, — Merriman's "Mechanics of Materials," Heller's "Stresses in Structures," and Goodman's "Mechanics Applied to Engineering."

The symbols used in the mathematical expressions are much the same as in Heller's "Stresses in Structures."

COLUMBUS, OHIO,
November 6, 1911.

CONTENTS.

	PAGE
PREFACE.....	v
NOTATION.....	xi
CHAPTER I. — STRESSES.....	1
Strength of Materials; Tension; Compression; Stress — Total Stress; Unit Stress; Working Stress — Allowable Unit Stress; Deformations — Unit Deformation; Elastic Limit; Modulus of Elasticity; Physical Meaning of E ; Resilience; Modulus of Resilience; Poisson's Ratio; Change in Volume inside the Elastic Limit.	
CHAPTER II. — STRESS BEYOND THE ELASTIC LIMIT.....	15
Stress-strain Diagrams; Elastic Limit and Yield Point; Johnson's Apparent Elastic Limit; Calculation of the Modulus of Elasticity; Ultimate Strength and Breaking Strength; Per cent of Elongation and Reduction of Area; Apparent and Actual Unit Stress; Curves of Various Structural Materials; Factor of Safety; Effect of Form on the Ultimate Strength; Effect of Stresses beyond the Yield Point.	
CHAPTER III. — SHEAR.....	37
Shear and Shearing Stress; Shearing Deformation; Modulus of Elasticity in Shear; Shear Caused by Tension or Compression; Shearing Forces in Pairs; Compressive and Tensile Stress Caused by Shear; Methods of Failure; Bearing Strength — Failure by Cutting.	
CHAPTER IV. — RIVETED JOINTS.....	54
Kinds of Stress; Bearing Stress; Lap Joint with Single Row of Rivets; Butt Joint; Rivets in More than One Row; Efficiency of a Riveted Joint.	
CHAPTER V. — BEAMS.....	66
Definition of a Beam; Kinds of Beams; Internal Stresses in Beams; External Moment and Resisting Moment; Experiments Illustrating Moment and Shear; Shear Diagrams; Moment Diagrams; Relation of Moment and Shear; Area of Shear Diagram Equals Moment.	

	PAGE
CHAPTER VI. — STRESSES IN BEAMS.....	85
Nature of Stresses; Relation of Moment to Stress; Unit Stress in the Outer Fibers; Location of Neutral Axis; Section Modulus; Graphic Representation of Stress Distribution; Stress beyond the Elastic Limit; Modulus of Rupture.	
CHAPTER VII. — DEFLECTION OF BEAMS.....	99
Deflection and Moment; Deflection in Rectangular Coördinates; Beam Supported at Two Points; Cantilever with Load on the Free End; Cantilever with Uniformly Distributed Load; Beam Supported at the Ends, Uniformly Loaded; Beam Supported at the Ends with Concentrated Load at the Middle; Beam Supported at the Ends, Load at any Point between Supports; Beam Supported at the Ends, Two Equal Loads Symmetrically Placed; Any Beam with Two Supports; Stiffness of Beams.	
CHAPTER VIII. — BEAMS WITH MORE THAN TWO SUPPORTS.....	119
Relation of Deflection to Stress; Cantilever Supported at One End; Cantilever Supported at One End, Concentrated Load; General Equations of Moment and Shear; Point of Inflection; Cantilever Fixed at Left End, Supported at Right End, Uniformly Loaded; Beam Fixed at Both Ends, Uniformly Loaded; Beam Fixed at Both Ends, Concentrated Load kl from the Left End; Theorem of Three Moments; Theorem of Three Moments for Distributed Loads; Calculation of Moments; Calculation of Shear; Theorem of Three Moments for Single Concentrated Load on Each Span; Superimposed Loads; Moments in Different Planes.	
CHAPTER IX. — SHEAR IN BEAMS.....	139
Direction of Shear; Intensity of Shearing Stress; Resultant of Shearing and Tensile Stress; Maximum Resultant Stress; Resultant Stress in Beams; Failure of Beams.	
CHAPTER X. — BEAMS OF SPECIAL FORM.....	153
Beams of Constant Strength; Cantilever with Load on the End; Shearing and Bearing Stresses at the End; Cantilever with Uniformly Distributed Load; Beams of Constant Strength, Supported at the Ends; Deflection of Beams of Constant Strength; Cantilever of Constant Depth with Load on End; Cantilever of Constant Breadth with Load on End; Cast-iron Beams; Beams of Two or More Materials; Reinforced Concrete Beams; Resisting Moment in Reinforced Concrete; Resultant Tensile Stress.	
CHAPTER XI. — BENDING COMBINED WITH TENSION OR COMPRESSION.....	169
Transverse and Longitudinal Loading; Eccentric Loading; Maximum Eccentricity without Reversing Stress; Resultant Load not on Principal Axis.	

CONTENTS

ix

	PAGE
CHAPTER XII. — COLUMNS.....	180
Definition; Column Theory; Application of Column Formulas; Euler's Formula; Effect of Ultimate Strength of Material on Strength of Columns; Classification of Columns; End Conditions in Actual Columns; Some Experiments Showing the Effect of End Conditions.	
CHAPTER XIII. — COLUMN FORMULAS USED BY ENGINEERS.....	202
Straight-line Formulas; Algebraic Derivation of the Straight-line Formulas; Ultimate Strength; Straight-line Formulas for Square or Fixed Ends; Rankine's or Gordon's Formulas; Ritter's Rational Constant; General Conclusions; Failure of Beams Due to Flexure on the Compression Side; Failure Due to Buckling of the Web.	
CHAPTER XIV. — TORSION.....	223
Torque; Shearing Stress in a Shaft; Relation of Torque to Angle of Twist; Relation of Torque to Work; Torsion Combined with Bending or Tension; Helical Springs.	
CHAPTER XV. — RESILIENCE IN BENDING AND TORSION.....	231
Beams; Expression for Internal Work; Cantilever with Uniformly Distributed Load; Beams with Variable Section; Leaf Springs; Resilience in Torsion; Sections of Maximum Resilience.	
CHAPTER XVI. — CENTER OF GRAVITY.....	239
Center of Gravity; Determination of Center of Gravity by Balancing; Center of Gravity by Moments; Center of Gravity of Continuous Bodies; Center of Gravity of Plane Areas.	
CHAPTER XVII. — MOMENT OF INERTIA.....	251
Definition; Radius of Gyration; Transfer of Axis; Moment of Inertia of Thin Plate; Moment of Inertia of Plane Area; Change of Direction of Axis; Product of Inertia; Transformation of Axes for Product of Inertia; Direction of Axis for Maximum Moment of Inertia; Moment of Inertia of a Prism or Pyramid.	
CHAPTER XVIII. — COMPUTATION WITHOUT INTEGRALS.....	268
Areas Which Cannot be Integrated; Approximate Computation; Center of Gravity by Experiment; Moment of Inertia by Experiment; Moment of Inertia of a Plane Section.	
CHAPTER XIX. — REPEATED STRESSES.....	275
Lag of Deformation behind Stress; Watertown Arsenal Tests of Eyebars; Failure under Repeated Stress; Design for Varying Stress; Impact Stresses.	



NOTATION.

The symbols which are frequently used in this book are:

- a = radius of circle; pitch of rivets.
 A = area of cross section.
 b = breadth; breadth of rectangular section; base of triangle.
 B = some special value of b .
- C, C_1, C_2 = integration constants.
 d = depth; height of rectangular section; diameter; distance between parallel axes.
 D = some special depth.
 e = eccentricity of load on column.
 E = modulus of elasticity.
- h = height.
 H = product of inertia.
 I = moment of inertia.
 I_x = moment of inertia with respect to the X axis.
 I_0 = moment of inertia with respect to an axis through the center of gravity.
 J = polar moment of inertia of a plane area.
 k = a constant coefficient (in Chapters VII, VIII).
 k = radius of gyration (in Chapter XVII).
- K, K_1, K_2 = constants of integration.
 l = length; length of beam between supports; length of column between points of counterflexure.
 L = length; total length of column.
 M, M_0 = moment, moment at origin of coördinates.
 M_a, M_b, M_c = moment over three consecutive supports.
 M_1, M_2, M_3 , etc. = moment over first, second, and third supports, etc.
 M_t = torque.
 N = normal force at surface.
- P, P_1 , etc. = concentrated loads or forces.
 r = radius of gyration (in Chapters XII, XIII).
 r = distance from origin (in Chapters XVI, XVII).
 R = reaction at support; resultant force.
 R_1 = reaction at left support.
 R_2 = reaction at right or second support.

- s = unit stress.
 s_t, s_c, s_s = unit tensile, compressive, and shearing stress.
 s_u = ultimate unit stress.
 s' = unit stress resulting from shear and compression or tension.
 S, S_0 = total vertical shear, total shear at origin.
 t = thickness.
 T = tension.
- v = distance from neutral axis.
 v_1 = distance of extreme lower fibers from neutral axis.
 v_2 = distance of extreme upper fibers from neutral axis.
 v_3 = some particular value of v .
 w = distributed load per unit length.
 W = total load uniformly distributed.
 $\bar{x}, \bar{y}, \bar{z}$ = coördinates of center of gravity.
 y = deflection of points on beam or column.
 y_{\max} = maximum deflection in a beam or column.
 δ = unit deformation.
 ρ = Poisson's ratio; density; radius of curvature.
 θ, ϕ = angles in figure.

STRENGTH OF MATERIALS.

CHAPTER I.

STRESSES.

1. **Strength of Materials.** — That branch of Mechanics which treats of the changes in form and dimensions of elastic solids and the forces which cause these changes is called *The Mechanics of Materials*. When the physical constants and the results of experimental tests upon the materials of construction are included with the theoretical discussion of the ideal elastic solid, the entire subject is called *The Strength of Materials* or *The Resistance of Materials*.

2. **Tension.** — Support one end of a band of soft rubber, and attach a small hook to the other end, as shown in Fig. 1. Now apply a small weight to the hook. The rubber band is stretched; its length is increased by an amount a , while its cross section is diminished. Add a second weight. If the second weight is equal to the first one, the elongation b , which it causes, is equal to that caused by the first weight. Remove the weights, and the rubber band returns to its original length and cross section.

If steel, iron, wood, concrete, stone, or other solid material is used instead of rubber, the results are similar. There is this apparent difference: while the rubber may be stretched to twice or three times its original length and still return to its original size and shape after the load is removed, one of the other materials

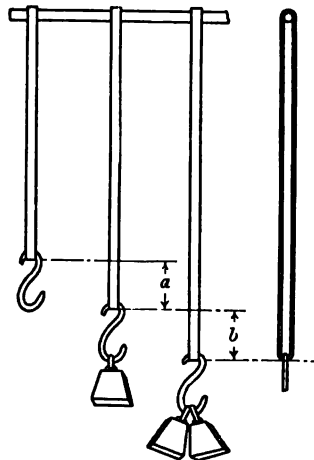

Fig. 1.— Rubber Bands in Tension.

may be stretched only a very small amount (usually less than 0.002 of its length), without receiving a permanent change in its dimensions. Again, the force required to produce a relatively small increase in the length of a rod of wood or steel, for instance, is many times greater than that necessary to *double* the length of a soft rubber band of equal cross section. These differences between the behavior of soft rubber and other solid materials are differences of degree and not of kind. Essentially they are alike.

The rubber bands shown in Fig. 1 are subjected to the action of two forces: the force of the weights pulling downward, and the reaction of the support pulling upward. The bands are in *tension*. A body is said to be in tension when it is subjected to two sets of forces whose resultants are in the same straight line, opposite in direction, and directed *away* from each other.

3. Compression. — When a body is subjected to two sets of

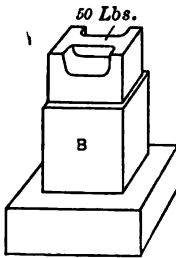

Fig. 2. — Compression.

forces whose resultants are in the same straight line, opposite in direction, and directed *toward* each other, it is said to be in *compression*. In Fig. 2, the block *B* is in compression under the action of the 50 pounds pushing down and the reaction of the support pushing up. The effect of compression upon a body is to shorten it in the line of the forces and increase its dimensions in the plane perpendicular to this line.

Tension and compression may be represented as in Fig. 3, where the arrows represent the forces, and the small rectangles represent the bodies, or portions of a body, upon which the forces act. The rectangles are often omitted; a pair of arrows with their heads together indicate compression, and a pair with their heads in the opposite sense indicate tension.

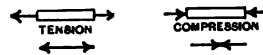

Fig. 3.

4. Stress; Total Stress. — The force exerted by one body upon another at their surface of contact is called the *stress* between the bodies or the *total stress* between the bodies. If a single body be regarded as cut by an imaginary surface, the force exerted across this surface by either portion of the body upon the other portion is the total *internal stress* in the body at the section.

In the case of an internal stress, if the forces are such that the portions of the body are pushed together at the imaginary surface, the stress is *compressive*. If the forces tend to pull the portions apart, the stress is *tensile*. Compressive stress at the surface of contact of two separate bodies is called *bearing stress*.

All parts of the bar AB , Fig. 4, are under tensile stress. The total tensile stress at any section CD is the load L and the weight of the hook and of that portion of the bar below the section.

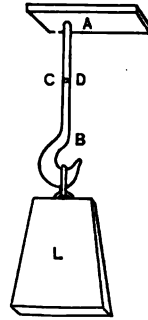

Fig. 4. — Tensile Stress.

All parts of the block in Fig. 5 are in compression. The total compressive stress at any section JK is 10 pounds plus the weight of the portion of the block above the section; or, since action and reaction are equal, it is the upward reaction at the base minus the weight of the portion below JK .

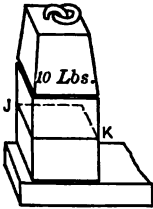

Fig. 5. — Compressive Stress.

5. Unit Stress; Intensity of Stress. — The *unit stress* at any surface is the total stress at the surface divided by its area.

Unit stress is frequently called *intensity of stress*. In American engineering practice, unit stresses are usually expressed in pounds per square inch. Compressive stresses in masonry are sometimes given in tons per square foot; the bearing pressure of masonry upon soils is always so expressed. English engineers frequently use long tons per square inch to express the intensity of stress in steel and similar solids.

Continental engineers, of course, use kilograms per square centimeter. Physicists, the world over, prefer dynes per square centimeter. In the case of tensile or compressive stresses, the surface considered is a plane section perpendicular to the direction of the forces, unless otherwise stated.

PROBLEMS.

- >1. The rod AB , Fig. 4, is circular and 2 inches in diameter. If the load L is 5000 pounds, and the weight of the hook and the lower part of the rod are neglected, what is the unit stress at any section?

Ans. 1592 pounds per square inch.

- >2. If in Fig. 4 the diameter of the rod is 3 inches, what must be the load L to produce an intensity of stress of 3500 pounds per square inch?

3. If a section of the block in Fig. 5 is $\frac{1}{2}$ inch by $\frac{1}{4}$ inch, what is the unit stress near the top? *Ans.* 32 pounds per square inch.

4. A 6-inch by 8-inch oak post 12 feet high supports a load of 6 tons at the top. The oak weighs 48 pounds per cubic foot. Find the unit compressive stress near the top and near the bottom.

Ans. 254 pounds per square inch near the bottom.

5. A concrete wall 18 inches thick and 12 feet high carries a load of 3300 pounds per running foot. The concrete weighs 150 pounds per cubic foot. Find the bearing pressure on the soil immediately under the foot of the wall.

Ans. 2 tons per square foot.

6. A 2-inch round steel rod is subjected to a pull of 100,000 pounds. Find the unit stress in pounds per square inch, long tons per square inch, kilograms per square centimeter, and dynes per square centimeter.

The total load upon a structure is often given in terms of the volume of some material. It is therefore advisable to learn the approximate density of some of the common substances. The figures given below will be used in problems throughout this book unless otherwise stated, and should be memorized.

Material.	Weight per cubic foot in pounds.
Water	62.5
Wrought iron	480
Steel	490
Cast iron	450
Concrete	150
Brick	125
Structural timber	48

A steel rod one inch square and one foot long is calculated as weighing 3.4 pounds. A wrought-iron rod of one square inch cross section weighs 10 pounds per yard.

PROBLEMS.

7. A 1-inch round steel rod 100 feet long hangs vertical and supports a tank weighing 125 pounds, which contains 14 cubic feet of water. Find the unit stress in the rod near the top. *Ans.* 1613 pounds per square inch.

8. A brick wall 12 inches thick, 30 feet high, and 15 feet long is supported by a steel beam 15 feet long and 19 square inches cross section. The ends of the beam are supported on two concrete columns each 12 inches square and 10 feet high. Find the unit stress near the bottom of the columns.

9. A floor is supported by long-leaf yellow-pine joists 2 inches by 12 inches by 16 feet, spaced 16 inches center to center. The floor is inch oak over inch hemlock. The lath and plaster weighs 14 pounds per square foot. Find the load on each joist including its own weight. (Take weights of timber from tables of the United States Department of Agriculture, given in Cambria.)

6. **Working Stress; Allowable Unit Stress.** — *Working stresses* are the unit stresses to which the materials of a structure or

machine are subjected. The *allowable unit stress* for a given material is the maximum working stress which, in the judgment of some engineer or other authority, should be applied to that material. As examples of allowable unit stresses, the building laws of New York city (see Cambria) and the American Railway Engineering and Maintenance of Way Association recommend 16,000 pounds per square inch as the allowable unit tensile stress in structural steel. The United States Department of Agriculture gives 1000 pounds per square inch as the allowable compressive stress, parallel to the grain, in long-leaf yellow pine, and 215 pounds per square inch across the grain.

PROBLEMS.

For allowable unit stresses in the following problems use the values recommended by the United States Department of Agriculture for timber, and those of the New York building laws for other materials, unless otherwise specified.

1. Find the total load in compression parallel to the grain which may be applied to a 4-inch by 4-inch short block of white oak.

Ans. 12,800 pounds.

2. What should be the length of a 6-inch by 6-inch block of short-leaf yellow pine to support a compressive load of 12,000 pounds across the grain?

Ans. 9.3 inches.

3. What should be the thickness of an eye-bar of rolled steel, 5 inches wide, to support 80,000 pounds in tension?

Ans. 1 inch.

4. What is the total tension which may be safely applied to a 1-inch wrought-iron bolt? (See table of Franklin Institute standard dimensions of bolts and nuts in Cambria.)

Ans. 6600 pounds.

5. An 8-inch by 8-inch short oak post stands on a cast-iron base plate which is supported by a pier of 1 : 2 : 4 Portland cement concrete. If the post is subjected to its allowable safe load, what should be the minimum area of the pier?

Ans. 223 square inches, 15 inches square.

6. If the pier in Problem 5 is 16 inches square at the top and enlarges to form a frustum of a pyramid 3 feet in height, what must be the dimensions of the base, if the bearing pressure on the soil shall not exceed 2 tons per square foot?

7. **Deformations; Unit Deformation.**— The changes in dimensions which occur when forces are applied to a body are called deformations. In Fig. 1, the increase of length, a , which takes place when the first load is applied is the deformation due to that load, the increase b is the deformation due to the second load, and $a + b$ is the deformation due to the two loads. The deformation produced by a *tensile* force or *pull* is an *elongation*; that caused by a *compressive* force or *push* is a *compression*. A

deformation which remains after the force is removed is called a *set*.

Unit deformation in a body is the deformation per unit length. It is calculated by dividing the total deformation in a given length by the original length. The length a in Fig. 1 divided by the original length of the band is the unit elongation due to the first load. It is frequently convenient to consider unit deformation as the ratio of the deformation to the original length. It is then called the *relative deformation*.

In algebraic equations many authors represent unit deformation by the letter δ (pronounced delta).

PROBLEMS.

1. A rod is subjected to a tensile stress and a portion of the rod, originally 8 inches long, is stretched 0.0040 inch. Find the unit elongation.

Ans. 0.00050 inch.

2. A block 4 inches long is compressed 0.0028 inch. What is the unit compression?

3. A change of temperature of 20° F. causes a relative elongation of 0.00013 in an iron rod. What is the total elongation in a length of 30 feet?

Ans. 0.0468 inch.

4. In the tension test of a bar of cast iron, it was found that a pull of 7000 pounds per square inch produced an elongation of 0.0044 inch in a length of 8 inches. What was the relative elongation?

Ans. 0.00055.

8. Elastic Limit. — When a stress is applied to a solid body and then removed, the body returns to its original size and shape, provided the stress has not exceeded a certain limit. If the stress has gone beyond this limit, the body does not return entirely to its original dimensions, but retains some permanent deformation or set. This limit is called the *elastic limit* of the material. A wrought-iron rod in tension is stretched about 0.006 inch in a length of 8 inches by a load of 20,000 pounds per square inch. When the load is removed, it returns to its original length. A stress of 20,000 pounds per square inch, or the corresponding unit elongation of 0.00075 inch, is below the elastic limit of wrought iron. If the load is increased to 30,000 pounds per square inch, the elongation in 8 inches becomes, perhaps, 0.075 inch. Upon the removal of the load the rod shortens only 0.009 inch and the residual 0.066 inch remains as a permanent set. The elastic limit is below 30,000 pounds per square inch.

9. Modulus of Elasticity. — For all stresses below the elastic limit the unit stress bears a constant ratio to the unit deformation. The quotient obtained by dividing unit stress by the accompanying unit deformation is called the *modulus of elasticity* of the material, or *Young's modulus*. In algebraic formulas, modulus of elasticity is represented by the letter E . Writing the above definition algebraically

$$E = \frac{s}{\delta}, \quad * \text{ Formula I.}$$

where E is the modulus of elasticity,
 s is the unit stress,
 δ is the unit deformation.

PROBLEMS.

➤ 1. A steel rod of 1 square inch cross section is tested in tension. It is found that a pull of 23,600 pounds stretches 8 inches of the rod 0.0064 inch. Find the unit deformation and the modulus of elasticity.

Ans. Modulus of elasticity, 29,500,000 pounds per square inch.

2. A wooden block 2 inches square and 12 inches long is tested in compression. It is found that a total load of 2800 pounds shortens 10 inches of the block 0.0050 inch. What is the modulus of elasticity of this wood?

Ans. 1,400,000 pounds per square inch.

3. A steel bar 1 inch by 5 inches is elongated 0.024 inch in a length of 5 feet by a certain load. If the modulus of elasticity of this steel is 30,000,000 pounds per square inch, what is the unit stress and the total load?

Ans. Total load, 60,000 pounds.

4. In a tension test of cast iron at the Watertown Arsenal, an increase of unit stress from 1000 pounds per square inch to 6000 pounds per square inch produced an increase in length of 0.0034 inch in a gauged length of 10 inches. Find E for this cast iron.

Ans. 14,700,000 pounds per square inch.

5. A 2-inch round steel rod is cooled from 80° F. to 30° F. without being allowed to contract. If the coefficient of expansion of the steel is 0.000067 per degree Fahrenheit, and the modulus of elasticity is 29,000,000, what is the total tension developed?

Ans. 30,520 pounds.

6. A cast-iron bar 2 inches wide and $\frac{1}{2}$ inch thick is placed between two steel bars each 2 inches wide by $\frac{1}{2}$ inch thick. If the modulus of elasticity of the steel is 30,000,000 and that of the cast iron 15,000,000, what total pull will stretch the combined bar 0.0044 inch in a length of 8 inches, and what will be the unit stress in each material?

Ans. Total pull, 24,750 pounds.

➤ 7. A steel bar 4 inches wide and 1 inch thick is placed between two wrought-iron bars each 4 inches wide and $\frac{3}{4}$ inch thick, and a total pull of 94,000 pounds is applied to the combination. If E for the steel is 30,000,000, and for the iron, 27,000,000, what is the unit tensile stress in each?

Ans. 10,000 pounds per square inch in the steel;
 9,000 pounds per square inch in the iron.

* Important formulas, which should be memorized, are designated by the Roman numerals in this book.

8. A 1-inch round steel rod passes through a wrought-iron pipe 1 inch inside diameter, 1.4 inches outside diameter, and 12 inches long. A nut on the rod is turned so as to produce tension in the rod and compression in the pipe. Neglecting the elasticity of the nut and of the projecting part of the rod, how much is the unit stress in each increased when the nut is turned 30 degrees, there being eight threads to the inch, and E the same as in Problem 7?

10. **Physical Meaning of E .** — Formula I of Article 9 may be written

$$\delta = \frac{s}{E}.$$

If s be made equal to unity, δ becomes equal to $\frac{1}{E}$. With the common engineering units, the reciprocal of E is the unit deformation produced by a unit load of one pound per square inch. For steel having a modulus of 30,000,000 pounds per square inch, a unit stress of one pound per square inch is developed when the deformation is one thirty-millionth of the original length.

EXAMPLES.

Solve without writing.

1. If wood having a modulus of 1,200,000 pounds per square inch is subjected to a tensile stress of 600 pounds per square inch, what is its elongation per inch of length? What is the total elongation in a length of 5 feet?
2. A 4-inch by 4-inch wooden block is subjected to a compressive force of 6400 pounds. If the modulus of elasticity parallel to the fibers is 1,600,000 pounds per square inch, what is the unit compression and the total compression in a length of 20 inches?
3. If steel has a modulus of 30,000,000, what is the unit elongation due to a load of 15,000 pounds per square inch?

Formula I may also be written

$$s = E\delta,$$

which defines E as the coefficient which multiplied into the unit deformation gives the unit stress. It helps to fix our ideas if we consider the case where the unit deformation is 0.001. We may then define the modulus as 1000 times the unit stress which produces a unit deformation of 0.001 of the original length.

EXAMPLES.

Solve without writing.

4. If the modulus of steel is 30,000,000, what is the unit stress when the unit deformation is 0.001? If the unit deformation is 0.0005, what is the unit stress? If a steel rod 40 inches long is stretched 0.008 inch, what is the unit

stress? What total pull will stretch a bar 2 inches square 0.024 inch in a length of 5 feet?

5. If the modulus of white oak is 1,500,000, what is the unit stress which produces a unit elongation of 0.001? Is this more or less than the allowable unit stress?

If, in Formula I, δ be made unity, s becomes equal to E . From this, the modulus of elasticity may be defined as the unit stress which would produce a deformation equal to the original length, if such deformation were possible without breaking the material or exceeding the elastic limit. This means the unit stress which would double the length of a bar in tension or reduce to nothing the length of a block in compression.

11. Resilience. — When force acts on a body and motion takes place in the direction of the force, the force does work on the body. The amount of work is measured by the product of the force multiplied by the distance its point of application moves along its line of action. When a body is *deformed* by a force, the amount of work is the product of the average force multiplied by the deformation. When the stress is kept below the elastic limit, the average force is the mean of the initial and final forces.

PROBLEMS.

1. A load of 6000 pounds is applied to a steel rod having no initial load and causes an elongation of 0.024 inch. What is the work in foot pounds?

Ans. 6 foot pounds.

2. An additional load of 9000 pounds is applied to the rod of Problem 1, producing an additional elongation of 0.036 inch. What is the additional work done on the rod (a) by the 9000 pounds alone? (b) by the 9000 pounds and the 6000 pounds together? (c) Compare the result of (b) with the work done if the entire 15,000 pounds is applied at once to the rod with no initial load.

Ans. (a) 13.5 foot pounds; (b) 31.5 foot pounds; (c) 37.5 foot pounds.

3. A load of 60,000 pounds in tension is applied to a steel bar of 4 square inches cross section. If the modulus of the steel is 30,000,000, how much work is done on a length of 10 feet of the bar?

Ans. 150 foot pounds.

4. A steel rod of 6 square inches cross section is stretched 0.072 inch in a length of 9 feet. If the modulus is 30,000,000, what is the total load, the average force, and the total work on the 9-foot length?

Ans. 360 foot pounds of work.

The work done in deforming an elastic body is stored up in the body as elastic energy, which may be given up in restoring the body to its original form when the load is removed. If the stress does not exceed the elastic limit, all this work is returned. If the stress exceeds the elastic limit, some of the work is converted into heat as the deformation takes place and cannot be recovered as mechanical energy.

12. Modulus of Resilience. — The work expended in deforming unit volume of any material to the elastic limit is called the *modulus of resilience* of the material. It is the *elastic potential energy* of unit volume when stressed to the elastic limit. The modulus of resilience is a *measure* of the amount of energy which may be stored in a given material and recovered as mechanical work without loss.

If we consider a cubic inch of material subjected to unit stress s , the deformation is $\frac{s}{E}$ and the average force is $\frac{s}{2}$; the total work is the product

$$\frac{s}{E} \times \frac{s}{2} = \frac{s^2}{2E}. \quad \text{Formula II.}$$

This expression (energy in unit volume = $\frac{s^2}{2E}$) gives the energy for any value of s below the elastic limit. When s is the unit stress at the elastic limit, the expression is the modulus of resilience. When s and E are given in pounds per square inch, Formula II gives the energy in *inch pounds per cubic inch*.

The total elastic energy in a body, all parts of which are subjected to a unit stress s , is obtained by multiplying the total volume of the body by the energy per unit volume, and is independent of the form of body.

PROBLEMS.

➤ 1. Find the modulus of resilience of structural steel having a modulus of elasticity of 29,000,000 and an elastic limit of 30,000 pounds per square inch. *Ans.* 15.5 inch pounds per cubic inch.

➤ 2. Find the modulus of resilience of spring steel for which E equals 30,000,000 and the elastic limit is 100,000 pounds per square inch.

Ans. 166.7 inch pounds.

3. A 2-inch round steel rod is subjected to a pull of 100,000 pounds, which produces an elongation of 0.012 inch in a 12-inch length. What is the total work expended on the 12-inch length? What is the work per cubic inch?

4. What is the modulus of resilience of wood having a modulus of elasticity of 1,200,000 and an elastic limit of 3000 pounds per square inch?

5. How many cubic inches of steel having an elastic limit of 80,000 pounds and a modulus of elasticity of 30,000,000 are required to store 100 foot pounds of energy? *Ans.* 11.25 cubic inches.

6. How high can the energy which may be stored in steel as used in Problem 5 lift its own weight? *Ans.* 31.37 feet.

In calculating the work of resilience, we used the *average force* multiplied by the deformation. We may obtain the same results by means of the Calculus.

Let x represent the total elongation of a rod of length l and unit cross section; and let dx represent an infinitesimal increment of this elongation. When the elongation is x the unit elongation is $\frac{x}{l}$ and the unit stress is $\frac{Ex}{l}$.

The work done in causing an elongation dx in the rod of unit cross section is the product of this unit stress multiplied by dx .

$$\text{Increment of work} = \frac{Ex}{l} dx. \quad (1)$$

$$\text{Total work} = \int \frac{Ex}{l} dx = \frac{E}{2l} [x^2]_{x_1}^{x_2} = \frac{E}{2l} (x_2^2 - x_1^2), \quad (2)$$

where x_1 and x_2 are the initial and final elongations respectively. Substituting for x_1 and x_2 their values in terms of the stress, we get:

$$\text{Total work} = l \left(\frac{s_2^2 - s_1^2}{2E} \right) = \left(\frac{s_2^2 - s_1^2}{2E} \right) \times \text{volume}. \quad (3)$$

If the initial stress is zero, equation (3) becomes Formula II.

PROBLEMS.

7. Derive equation (2) by means of average force without integrating.
8. Derive the expression for total work and work per unit volume in a bar of length l , cross section A , and modulus E , when the total load changes from P_1 to P_2 , and show that the final expression for total work is the same as equation (3) above.

13. Poisson's Ratio. — When a body is subjected to a tensile stress it is elongated, the amount of elongation, provided the unit stress does not exceed the elastic limit, being proportional to the stress. At the same time its diameter is diminished. The ratio of this relative decrease in diameter to the unit increase in length is called Poisson's ratio. The value of this ratio varies with the material, but it is usually in the neighborhood of $\frac{1}{4}$. It is about 0.27 for steel. If a steel rod is elongated 0.001 of its length, its diameter is diminished about 0.00027 of its original value. The same relation holds in compression.

PROBLEMS.

→ 1. Taking Poisson's ratio as 0.27 and the modulus of elasticity as 30,000,000, find the decrease in diameter of a 2-inch round steel rod under a pull of 100,000 pounds.

2. In Problem 1, if the unit stress is proportional to the unit deformation, what is the transverse unit compressive stress?

Ans. 8594 pounds per square inch.

→ 3. A block of metal 2 inches square and 10 inches long is subjected to a compressive stress parallel to its length which makes the unit deformation 0.001. If Poisson's ratio is $\frac{1}{4}$, how much is its volume diminished?

Ans. 0.02 cubic inch nearly.

4. A block of metal, in the form of a rectangular parallelepiped whose edges correspond with the axes of Cartesian coördinates, is subjected to a compressive stress of 4800 pounds per square inch along the *X* axis. If the modulus of elasticity in both compression and tension is the same in all directions, what is the unit stress and unit deformation in each of the principal directions when *E* equals 30,000,000 and Poisson's ratio is $\frac{1}{4}$?

	Axis.	Unit Deformation.	Unit Stress.
<i>Ans.</i>	<i>X</i>	0.00016 compression	4800 lbs. per sq. in.
	<i>Y</i>	0.00004 tension	1200 lbs. per sq. in.
	<i>Z</i>	0.00004 tension	1200 lbs. per sq. in.

5. Solve Problem 4 if the applied stress is 6000 pounds per square inch compression along the *X* axis and 4800 pounds per square inch tension along the *Y* axis.

	Axis.	Unit Deformation.
<i>Ans.</i>	<i>X</i>	0.00024 compression.
	<i>Y</i>	0.00021 tension.
	<i>Z</i>	0.00001 tension.

14. Change in Volume inside the Elastic Limit. — If a body of unit dimensions is elongated an amount δ due to an external pull, its length becomes $1 + \delta$, and its transverse dimensions become $1 - \rho\delta$, where ρ^* is Poisson's ratio. Its area of cross section becomes $(1 - \rho\delta)^2 = 1 - 2\rho\delta + (\rho\delta)^2$. Since $(\rho\delta)$ is small, being never greater than 0.001, $(\rho\delta)^2$, being more than a thousand times smaller, may be neglected without appreciable error.

The volume is $(1 + \delta)(1 - 2\rho\delta) = 1 + (1 - 2\rho)\delta - 2\rho\delta^2$.

The last term, $2\rho\delta^2$, may also be neglected.

Final volume = $1 + (1 - 2\rho)\delta$;

Original volume = 1;

Increment of volume = $(1 - 2\rho)\delta$.

PROBLEMS.

1. If Poisson's ratio is $\frac{1}{4}$, show that the relative increase in volume when a tension is applied is one-half as great as the relative increase in length.

* Greek letter ρ , pronounced rho.

2. In the case of compression, find the ratio of the increment of volume to the increment of length.

3. A steel bar of 6 square inches cross section is subjected to a pull of 90,000 pounds. If Poisson's ratio is 0.27 and E is 30,000,000, what is the increase in volume of a 10-inch length?

Solve by means of the formula above, and also by multiplying together the dimensions without omitting any figures, and compare the results.

4. Show that a body for which Poisson's ratio is $\frac{1}{2}$ has its volume unchanged by a direct stress.

Note that the discussion of Articles 13 and 14 applies to stresses and deformations below the elastic limit, for which all deformation is temporary. For stresses beyond the elastic limit, producing permanent deformation and rearrangement of the molecules of the body, the conditions are somewhat different.

MISCELLANEOUS PROBLEMS.

1. A stick of Douglas fir tested in tension at the Watertown Arsenal ("Tests of Metals," 1896, page 405) showed an elongation of 0.0427 inch in a gauged length of 200 inches when the load per square inch changed from 100 pounds to 500 pounds. Find E . *Ans.* 1,874,000 pounds per square inch.

2. A second stick of Douglas fir tested in tension (1896, pages 407-9) showed an elongation of 0.1015 inch in a gauged length of 200 inches, and a decrease of width of 0.0020 inch in a width of 12 inches when the load changed from 100 pounds to 1000 pounds per square inch. Find the modulus of elasticity in tension parallel to the grain and Poisson's ratio.

Ans. Poisson's ratio, 0.33.

3. In a compressive piece cut from the stick of Problem 2, when the compressive stress changed from 100 pounds to 1000 pounds per square inch there was a compression of 0.0230 inch in a gauged length of 50 inches. Find E .

4. A white-oak stick 11.98 inches by 9.95 inches tested in compression (1896, page 425) was shortened 0.0140 inch in a gauged length of 50 inches when the load was increased from 11,920 pounds to 71,520 pounds. Find E .

5. A block of the same oak used in Problem 4 was tested in compression across the grain. When the unit stress changed from 20 pounds per square inch to 320 pounds per square inch the compression in a gauged length of 6 inches was 0.0091 inch. Find the modulus of elasticity of oak across the grain.

Ans. 199,000 pounds per square inch.

6. Two blocks of Douglas fir were tested in compression across the grain. In the first block the compression was normal to the growth rings, and the compression in a gauged length of 6 inches when the unit load changed from 20 pounds to 300 pounds was 0.0081 inch. In the second block the compression was tangent to the growth rings, and the compression in 6 inches with the same change of load was 0.0195 inch. Find E for each case. ("Tests of Metals," 1896, pages 396-7.)

7. A steel column 100 feet long and of uniform cross section stands in a vertical position. If the modulus of elasticity is 30,000,000, how much is it shortened by its own weight? Solve by Calculus and check by average force.

Ans. 0.0068 inch.

8. A round steel rod tapers gradually from 2 inches diameter to 1 inch diameter in a length of 10 inches. If E is 30,000,000, and if we assume that the unit stress in any transverse section is uniform throughout the section, calculate by means of Integral Calculus the elongation in this 10-inch length due to a pull of 20,000 pounds. *Ans.* 0.00424 inch.

9. A plate of uniform thickness t has a breadth b at one end of a given length l and a breadth c at the other end. Find the expression for the elongation of this length l due to a pull P . *Ans.* $\frac{Pl}{Et(c-b)} \log \frac{c}{b}$.

10. In Problem 9, E is 30,000,000; P , 40,000 pounds; t is 1 inch; b is 2 inches; c is 3 inches; l is 12 inches. Find elongation and check approximately by comparing with a bar of uniform breadth 2.5 inches.

The ratio of unit stress which is equal in all directions to the unit volume deformation which it causes is called the *modulus of volume elasticity*. A solid submerged in a liquid is under stress of this kind.

If Poisson's ratio is known, the modulus of volume elasticity may be computed from the modulus in tension or compression. When a solid is subjected to a stress in all directions, the unit deformation in any direction is the sum of the deformation in that direction due to the force in the same direction plus the deformation due to the force in each of the other principal directions. If δ is the deformation along the X axis due to a force in the direction of that axis, an equal force along the Y axis produces a deformation $\rho\delta$, and a similar force along the Z axis has the same effect. When the force is compressive and equal in all directions, the unit deformation along any axis $-\delta + \rho\delta + \rho\delta - \delta(1 - 2\rho)$. A unit cube has each dimension changed from unity to $1 - \delta(1 - 2\rho)$. The volume of this cube becomes

$$V = [1 - \delta(1 - 2\rho)]^3 = 1 - 3\delta(1 - 2\rho), \text{ etc.}$$

The increment of volume is $-3\delta(1 - 2\rho)$.

If E is the modulus of elasticity in tension or compression when the force is applied along only one direction,

$$\delta = \frac{s}{E},$$

where s is the unit pressure.

The increment of volume, or unit volume deformation (since the original volume was unity), becomes

$$\frac{3s}{E}(1 - 2\rho).$$

Dividing the unit stress by the unit volume deformation,

$$E_v = \frac{E}{3(1 - 2\rho)},$$

where E_v is the modulus of volume elasticity.

If Poisson's ratio is $\frac{1}{4}$, $E_v = \frac{2E}{3}$.

PROBLEMS.

11. Find the modulus of volume elasticity for steel for which $E = 29,000,000$ and Poisson's ratio is 0.27. *Ans.* 21,000,000 nearly.

12. If the modulus of volume elasticity is 18,000,000 and the modulus in compression is 25,000,000, find Poisson's ratio.

CHAPTER II.

STRESS BEYOND THE ELASTIC LIMIT.

15. **Stress-strain Diagrams.** — In the preceding chapter we have considered only stresses below the elastic limit. Within this limit the unit stress is proportional to the unit deformation and Formula I holds good. Stresses below the elastic limit are the most important from the standpoint of the engineer, for in well-designed structures the unit stress seldom exceeds one-half this limit. It is desirable, however, to know what takes place above the elastic limit and the character of the final failure of the material. To secure this information, tests are made in which a series of loads are applied to a piece of the material in question, and the corresponding deformations are observed with suitable measuring apparatus. Table I gives a part * of the results of a tension test of a rod of † machine steel. The rod was originally 20 inches long and turned to a diameter of 1.31 inches. About 9 inches of the rod at the middle was turned down further to a diameter of 1.115 inches. A length of 8 inches in this middle portion was taken as the gauged length from which to measure elongations. The rod *I* on the right in Fig. 6 (photographed from a rod exactly like the one tested) shows the original form of this test piece. The elongations in this gauged length were measured by an extensometer reading to 0.0001 inch (see Johnson's "Materials of Construction," Fig. 271). As there are two micrometers in this extensometer, we are warranted in giving the gauge readings to 0.5 of a division. When the load reached 78,000 pounds per square inch, the extensometer was removed and the elongations taken with an ordinary steel scale reading in hundredths of an inch. After fracture the rod was taken from

* Readings were taken at 2000-pound intervals from 56,000 to 76,000 pounds per square inch, and were used in locating the curve of Fig. 6. Readings were also taken at 2000-pound intervals between 30,000 and 40,000 pounds per square inch, as it was suspected that the yield point might fall between these limits.

† An analysis of this steel, made by Prof. D. J. Demorest, gave: carbon, 0.42 of 1 per cent; manganese, 0.71 of 1 per cent. The rod was turned from a bar of hot-rolled steel.

the machine, the two portions placed together as shown in Fig. 6, II, and the final elongation of 1.99 inches measured. Loads were applied and measured by means of a 100,000-pound Olsen testing machine (see Johnson's "Materials of Construction," Fig. 256).

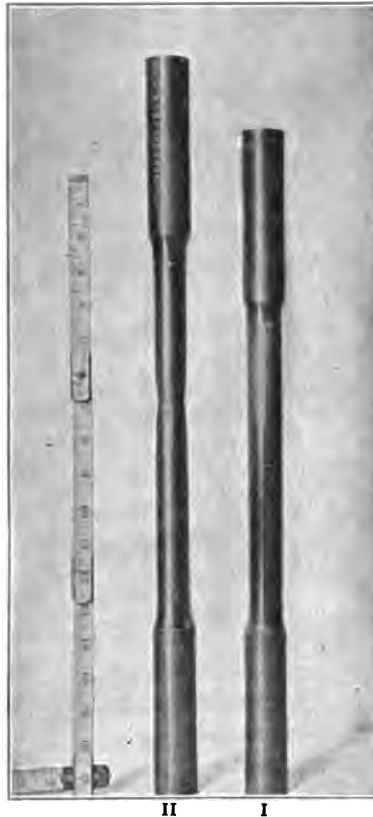

Fig. 6. — Steel Rod Tested in Tension.

In order to present the results of such a test visually, it is convenient to use the unit stress and the unit elongation as the coordinates in a curve called the *stress-strain* * *diagram*, or simply *stress diagram*.

* This is using the word "strain" in its correct sense as a synonym for deformation. A permanent deformation or set is frequently designated as a strain. The term "strain" is frequently heard where stress is meant. This incorrect use of the word should be avoided.

STRESS BEYOND THE ELASTIC LIMIT 17

TABLE I.

TENSION TEST OF MACHINE STEEL.

Diameter, 1.115 inches; area of section, 0.976 square inch; gauged length, 8 inches.

Applied load.		Elongation.	
Total.	Per square inch.	In gauged length.	Per inch length.
Pounds.	Pounds.	Inch.	Inch.
0	0	0	0
2,928	3,000	.00085	.00011
4,880	5,000	.00145	.00018
9,760	10,000	.00260	.00033
14,640	15,000	.00410	.00051
19,520	20,000	.00535	.00067
24,400	25,000	.00665	.00083
29,280	30,000	.00795	.00099
34,160	35,000	.00920	.00115
39,040	40,000	.01075	.00134
40,992	42,000	.0114	.00142
42,944	44,000	.0144	.00180
44,896	46,000	.0356	.00445
44,000	45,080	.0734	.00917
44,500	45,504	.0965	.01206
45,000	46,100	.0973	.01216
45,872	47,000	.0981	.01226
46,848	48,000	.0991	.01239
47,824	49,000	.1013	.01266
48,800	50,000	.1163	.01454
50,752	52,000	.1273	.01589
52,704	54,000	.1381	.01726
54,656	56,000	.1552	.01940
64,416	66,000	.2601 (1)*	.03250
74,176	76,000	.4244 (2)	.05530
76,128	78,000	.50 (by	.0625
78,080	80,000	.59 scale)	.074
79,056	81,000	.70	.0875
80,032	82,000	.76	.095
81,008	83,000	.85	.106
81,984	84,000	.99	.124
83,000	85,040	1.24	.155
83,200	85,240	1.50	.187
82,000	84,100	1.64 (3)	.205
80,000	82,000	1.85 (4)	.231
72,000	73,800 (broke)	1.99 (5)	.247

(1) Diameter, 1.097 inches.

(2) Diameter, 1.083 inches.

(3) Begins to "neck."

(4) Diameter of neck, 0.904 inch.

(5) Elongation measured after fracture. Diameter of neck, 0.821 inch.

Steel, hot rolled; carbon, 0.42 per cent.

In America, the unit stress in pounds per square inch is used as ordinate, and the unit deformation is taken as abscissa. In England, some writers use unit stress as abscissa and unit deformation as ordinate.

Fig. 7 is the stress-strain diagram plotted from Table I. One division on the horizontal scale represents a unit elongation of 0.01, and one division on the vertical scale represents a unit stress of 5000 pounds per square inch.

Fig. 8 is a part of the stress-strain diagram from the same table plotted on an enlarged scale; one division on the horizontal repre-

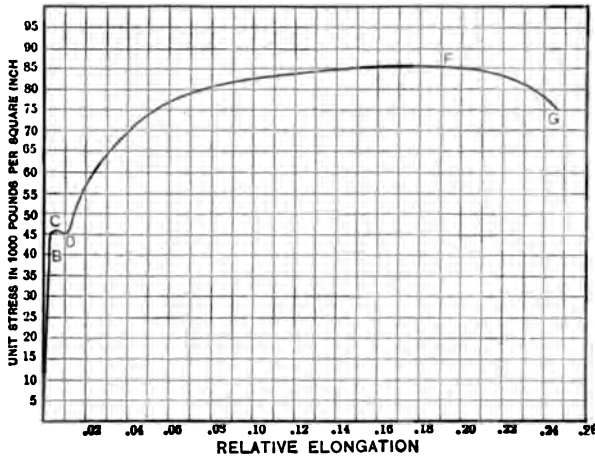

Fig. 7. — Stress-strain Diagram of Machine Steel.

sents a unit elongation of 0.0002 inch per inch of length (one-fiftieth as much as in Fig. 7); one division on the vertical represents a unit stress of 2500 pounds per square inch (one-half as much as in Fig. 7).

16. **Elastic Limit, and Yield Point.** — The point *B* in Figs. 7 and 8 represents the *true elastic limit*. Up to that point the curve is a straight line. In other words, the unit stress is proportional to the unit deformation below this point. Above *B*, the curve deviates from the straight line. Up to a unit stress of 42,000 pounds per square inch this deviation is slight, and it is difficult to locate the point *B* exactly. From 42,000 to 44,000 pounds the change is more rapid. This may be seen from Table I. Below 35,000 pounds per square inch the increase in the total

elongation for an increment of 5000 pounds in the unit stress is about 13 divisions. Between 35,000 and 40,000 pounds unit stress the stretch is 15.5 divisions. Between 40,000 and 42,000 the rate is slightly greater. Between 42,000 and 44,000 pounds the increase amounts to 30 divisions, the rate being over five times that below the true elastic limit.

At C, at a unit stress of 46,000 pounds per square inch, the curve becomes horizontal. This is the *yield point*. Beyond the

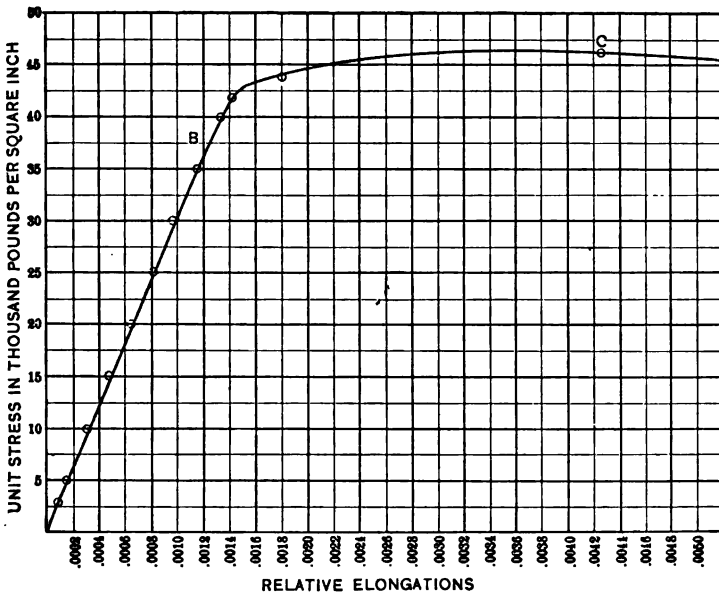

Fig. 8. — Part of Diagram for Machine Steel.

yield point the curve drops to a unit stress of about 45,000 pounds per square inch. Not only is there an increase of length with no increase of stress, but there is a considerable elongation with a diminished stress. In changing down to 45,000 pounds and back again to 45,500 pounds, the increase in length is nearly twice as great as the entire elongation up to the yield point, and five times as great as the elongation from zero load to a stress of 42,000 pounds per square inch. At the yield point, steel and wrought iron stretch like taffy, though the force required is probably one hundred thousand times as great.

As the stress-strain diagram deviates slowly from a straight line at first, it is difficult to locate the *true elastic limit*. On the other hand, the stress at the yield point may be easily determined in rapid commercial tests and without delicate apparatus for measuring the elongations. If we consider Table I, we find that the total elongation in the gauged length of 8 inches is about one-seventieth of an inch at a unit stress of 44,000 pounds, and rises to more than one-thirtieth of an inch at a unit stress of 46,000 pounds. This increase in length may easily be measured with an ordinary scale, so that the yield point may be determined within one or two thousand pounds without the use of any extensometer whatever. Again, just beyond the yield point the elongation is increased with a diminished load. This may easily be determined in rapid commercial tests in which the testing machine is kept running continuously. Before reaching the yield point, the poise on the beam of the weighing apparatus must be continually moved out to preserve a balance, showing that the stress is increasing with the elongation. At the yield point the "beam drops" while the elongation increases, and the poise must be moved backward to secure a balance. In iron or steel which has not been turned or polished, and is therefore covered with a coat of oxide, the yield point may be determined by this oxide breaking loose and falling. We sometimes see a portion of a rod reach the yield point before the remainder; the oxide falls from this portion, while the other parts of the bar are unchanged till the stress becomes a little greater. The curve in such a rod will show several steps or bends beyond the first yield point, corresponding to the yield points of the various portions.

Owing to the fact that the yield point may be determined so easily, by methods which were in use before delicate extensometers were available, the term "*elastic limit*" is commonly applied to what is really the *yield point*. When the term "*elastic limit*" is used in specifications, *yield point* is frequently meant. The point *B*, where the curve deviates from the straight line, is distinguished by some writers as the *true elastic limit*. Since the deformation is proportional to the unit stress for values below this point, it is also called the *proportional elastic limit*.*

* See Chapter XIX for effect of time on the form of the stress-strain diagram of steel.

17. Johnson's Apparent Elastic Limit. — Since it is somewhat difficult to determine the true elastic limit accurately, especially in hard steel, where there is a wide range between this point and the yield point, and in materials (such as cast iron) which have no yield point, the late Prof. J. B. Johnson proposed another point which he called the "*apparent elastic limit*."* He defined the apparent elastic limit as "the point on the stress diagram at which the rate of deformation is 50 per cent greater than at the origin." It is that point on the curve at which the slope of the tangent from the *vertical* is 50 per cent greater than that of the straight-line part of the curve.

This term has not yet come into general use among engineers. In some investigations of the strength of materials, it has been found useful in comparing the results of different tests.†

18. Calculation of the Modulus of Elasticity. — The stress-strain diagram, when plotted to a sufficiently large scale, enables us to calculate quickly the *average* value of the modulus of elasticity. If the straight line passes through the origin, we merely find the value of stress which corresponds to some convenient unit elongation such as 0.001 or 0.0005. If the straight line does not pass through the origin, we get the difference of stress for some convenient difference of elongation. In either case, to get the modulus, we divide the difference in stress by the corresponding difference in elongation.

PROBLEMS.

-1. From the curve of Fig. 8 find the unit stress which corresponds to the unit elongation 0.001, and calculate E to three significant figures.

2. From Fig. 8 find the unit elongation which corresponds to the unit stress of 25,000 pounds, and compute E to three significant figures.

>3. From the data of Table I plot the stress-strain diagram up to the unit stress of 42,000 pounds per square inch to the scales 1 inch equals a unit stress of 5000 pounds per square inch and a unit elongation of 0.0002 inch per inch of length. Use paper ruled in 0.1 inch units. Draw the curve as a light line and solve Problems 1 and 2.

It is, of course, not necessary to plot the stress diagram in order to solve for E . The diagram enables us to compute a good *average* value with a single calculation. It also enables

* See Johnson's "Materials of Construction," pages 18-20.

† See work of H. F. Moore in Bulletin No. 42 of the University of Illinois Engineering Experiment Station, page 14.

us to judge of the accuracy of the test by observing how closely the points fall on the straight line. In an autographic testing machine, where the curve is automatically drawn as the piece is tested, it is important to be able to determine the modulus from the curve.

Where the readings are available, as in Table I, these may be used in determining E . If all the readings were exactly correct, so that all would fall exactly on the straight line when plotted to any scale, any one such reading would give a correct result. Since there is some probable error in balancing the scales and setting the extensometers, there will be some variation in the values of E taken from the different intervals. The relative accuracy is practically proportional to the interval. The value of E from a 20,000-pound interval should be given twice the weight which is given to the result of a 10,000-pound interval.

Of course, all readings for calculating E must be taken below the true elastic limit. If the curve is not plotted, this may be determined by observing the point where the increment of elongation corresponding to a given increment of stress permanently increases. As shown in Article 16, this is between 35,000 and 40,000 pounds per square inch for the steel of Table I.

PROBLEMS.

4. From Table I calculate E , using the intervals 0-25,000 and 0-30,000 pounds and the exact unit elongation calculated from the total elongation. What relative *weights* may be given to the two results in averaging them?

Ans. Relative weight, 5 : 6. Mean E , 30,140,000.

→ 5. Calculate E for three intervals of 25,000 pounds per square inch; from 0 to 25,000, from 5000 to 30,000, and from 10,000 to 35,000. Average the results.

Ans. Mean E , 30,350,000.

6. Calculate the weighted mean for all the readings without computing the separate values of E , by adding together all the micrometer readings and all the stresses and using the totals as the unit stress and the total elongations respectively.

Ans. E equals 29,990,000.

7. If you are using the interval of 30,000 pounds, what error in E would an error of one division in the extensometer reading produce? What would be the error in E due to an error of 10 pounds in the total load?

19. **Ultimate Strength and Breaking Strength.** — The point F at the top of the curve of Fig. 7, representing a unit stress of a little more than 85,000 pounds per square inch, gives the *ultimate strength* of the steel under test. The rod at this stress was elongated 1.5 inches in the gauged length of 8 inches, and the diam-

eter was practically uniform throughout this length. Beyond this elongation, the rod began to "neck"; its diameter decreasing rapidly at *one section*, while the remainder was not changed. When the load had dropped to about 82,000 pounds per square inch, the minimum diameter at the neck was 0.904 inch, while that of most of the gauged length was a little over 1 inch. It finally broke at a total load of 72,000 pounds, which, in terms of the original area, corresponds to a unit stress of 73,800 pounds per square inch. This is the *breaking strength*, the point *G* of Fig. 7.

Most materials, such as wood, cast iron, concrete, and hard steel, do not neck; the ultimate strength corresponds with the breaking strength.

20. Per cent of Elongation and of Reduction of Area. — The per cent of elongation in ductile materials, such as wrought iron and steel, is an important factor. (See Cambria for the minimum values in the Manufacturers' Standard Specifications. See also latest Proceedings of the American Society for Testing Materials.) In tension tests the gauged length of 8 inches is subdivided into inch intervals by punch marks, Fig. 6, I. If we observe the tested rod, Fig. 6, II, we notice a considerable variation in the distance between points which were originally one inch apart. Measurements of the rod are as follows:

Interval.	Elongation.	
0-1.....	0.17 inch	
1-2.....	.19 "	
2-3.....	.31 "	
3-4.....	.54 "	included neck.
4-5.....	.25 "	
5-6.....	.19 "	
6-7.....	.17 "	
7-8.....	.17 "	

If we use only the interval 3-4, which included the neck, we get an elongation of 54 per cent. If we take the 4-inch interval 0-4, we get 30.2 per cent. In order to make the results of different tests comparable with one another, the Society for Testing Materials has adopted 8 inches as the standard gauged length for rods $\frac{1}{4}$ inch and upwards. (See Manufacturers' Specifications, Article 12, in Cambria.)

The per cent of reduction of area at the neck is also of interest. In the rod of Table I, the original diameter was 1.115 inches and the final diameter was 0.821 inch. The final area of the neck

was 54.2 per cent of the original area. The reduction was 45.8 per cent.

Table I is for steel containing 0.42 per cent carbon. For *structural* steel, compare the annealed rod of Table V.

PROBLEMS.

1. From the above measurements find the per cent of elongation for the four intervals 4-8, which do not include the neck. Find also the per cent of elongation for the entire gauged length.

2. A rod of soft steel, originally 0.874 inch in diameter, was tested in tension. After fracture under a load of 28,000 pounds, the diameter of the neck was found to be 0.570 inch. What was the per cent of reduction of area? What was the breaking strength?

Ans. 57.5 per cent; 46,700 pounds per square inch.

3. In Problem 2, the maximum load was 36,000 pounds. Find the ultimate strength.

21. Apparent and Actual Unit Stress. — The unit stresses in Table I were calculated by dividing the total load by the original area of cross section. This is the usual custom, and, unless otherwise stated, all tables and curves are given in this way. Owing to the fact that the area of cross section is permanently reduced when the yield point is reached, the *actual* unit stress is different. At the time of rupture of Table I, the total load was 72,000 pounds and the apparent unit stress was 73,800 pounds per square inch. The actual diameter of the neck at fracture was 0.821 inch, which gives an *actual unit stress* of 136,000 pounds per square inch. The curve of Fig. 7 falls from *F* to *G*. The actual stress increases for all loads except at the yield point.

PROBLEMS.

1. Calculate from Table I the actual unit stress when the total elongation was 1.85 inches.

2. Calculate the actual unit stress when the apparent unit stress was 76,000 pounds per square inch.

To get the actual unit stress after the rod begins to neck, we must measure the diameter of the smallest section at each load. Before necking begins, the mean area of the cross section may be computed from the fact that the volume and density remain nearly constant. Accordingly, the area of cross section is inversely as the length, and the ratio of actual to apparent unit stress is directly as the length. If *A* is the original cross section

and A' the actual area corresponding to a given unit elongation, δ ,
 $A = A'(1 + \delta)$ and

Actual stress = apparent stress multiplied by $(1 + \delta)$.

PROBLEMS.

3. Calculate the diameters corresponding to unit stresses of 66,000 and 76,000 and compare results with Table I.

4. Compute the actual unit stress for Table I for all apparent stresses above 45,000 pounds per square inch, and plot curve with coördinates as follows: One inch equals a unit deformation of 5 per cent and a unit stress of 20,000 pounds per square inch.

The student may notice an apparent discrepancy between the statements above and those of Article 14. Poisson's ratio and the discussion of Article 14 apply only to stresses and deformations inside the elastic limits, where all deformations are *temporary* and relatively very small. The discussion above refers to the permanent changes beyond the elastic limit. The temporary deformations, to which Poisson's ratio applies, are, of course, superimposed on these permanent deformations; but they are relatively so small that they can only be measured with delicate instruments. In the test of Table I the unit deformation at the elastic limit was a little over 0.001; and the corresponding decrease in diameter calculated by Poisson's ratio was about 0.0003 inch.

The density does not remain *exactly* constant, but the differences are beyond the limits of accuracy of the elongation measurements.

22. Curves of Various Structural Materials. — The curves of Figs. 7 and 8 give a fair average idea of the behavior of machine steel in tension. Structural steel, with a smaller per cent of carbon, has a yield point of a little over 30,000 pounds per square inch and an ultimate strength of about 60,000 pounds per square inch. Its modulus of elasticity is about 29,000,000. Tool steel has a yield point above 50,000 pounds and an ultimate strength of over 100,000 pounds. The heat and mechanical treatment have a great effect upon these factors but very little effect upon the modulus of elasticity.

Table II and curve II of Fig. 9 represent the behavior of cast iron in tension. The table is the mean of the tests of six bars from the same heat. The figures represent what may be expected in good cast iron.

Table II is from the average of six tests, specimens 8014, 8041, 8050, 8051, 8053, and 8063, at the Watertown Arsenal ("Tests of Metals," 1905).

The average ultimate load was 26,450 pounds per square inch.

The actual initial load was 1000 pounds. The table is calculated on the assumption that the elongation from 0 to 1000 is the same as from 1000 to 2000.

The curve for this cast iron is plotted to the same scale as Fig. 8, and a part of the curve of steel from Fig. 8 is drawn for comparison. The dotted line shows approximately the initial

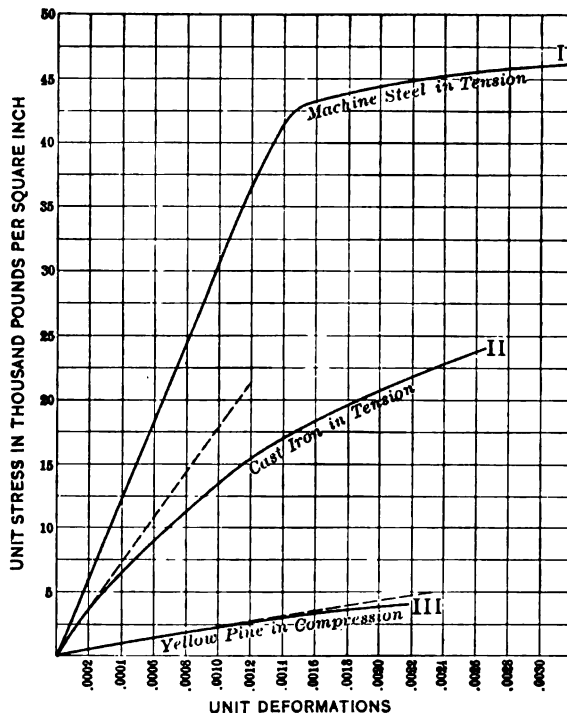

Fig. 9.

slope of the cast-iron stress diagram. The curve begins to bend almost at the start, and it is difficult to locate the true elastic limit. There is no yield point, and the material breaks without necking.

PROBLEMS.

1. From the dotted line of curve II, Fig. 9, calculate the modulus of elasticity of cast iron. Check result by means of the readings of Table II.
2. From the curve of Fig. 9 find Johnson's apparent elastic limit and compare the result with the table. Also construct a curve for which the abscissas

STRESS BEYOND THE ELASTIC LIMIT 27

are unit stress, and ordinates are the *differences* between successive unit deformations and 56, and determine the apparent elastic limit from the abscissa of the point for which the ordinate is 28.

3. From Tables I and II determine the ratio of the elongation of steel at rupture to that of cast iron.

4. If we take 2000 pounds as the true elastic limit of cast iron in tension, what is its modulus of resilience?

TABLE II.
TENSION TEST OF CAST IRON.

Diameter, 1.129 inches; area, 1 square inch; gauged length, 10 inches.

Load per square inch.	Elongation.	
	In gauged length.	Per inch length.
Pounds.	Inch.	Inch.
1,000	0.00056	0.000056
2,000	.00112	.000112
3,000	.00171	.000171
4,000	.00236	.000236
5,000	.00303	.000303
6,000	.00374	.000374
7,000	.00446	.000446
8,000	.00526	.000526
9,000	.00606	.000606
10,000	.00691	.000691
11,000	.00779	.000779
12,000	.00871	.000871
13,000	.00968	.000968
14,000	.01061	.001061
15,000	.01174	.001174
16,000	.01283	.001283
17,000	.01404	.001404
18,000	.01544	.001544
19,000	.01689	.001689
20,000	.01851	.001851
21,000	.02003	.002003
22,000	.02182	.002182
23,000	.02420	.002420
24,000	.02626	.002626

Table III, and curve III of Fig. 9, represent the behavior of long-leaf yellow pine in compression. Like steel, the curve for timber is a straight line for a considerable portion of its length. In other respects it resembles the curve for cast iron. The post

represented by Table III failed outside of the gauged portion; the ultimate elongation is, therefore, less than it would be if the failure had occurred inside of this length.

TABLE III.

COMPRESSION TEST OF LONG-LEAF YELLOW PINE.

From Watertown Arsenal Report, 1897, page 420.

Length of post, 10 feet. Dimensions, 9.75 inches by 9.77 inches.

Area, 95.26 square inches. Gauged length, 50 inches.

Applied load.		Deformation.	
Total.	Unit stress per square inch.	In gauged length.	Unit per inch length.
Pounds.	Pounds.	Inch.	Inch.
9,526	100	0.0021	0.000042
19,052	200	.0044	.000088
28,578	300	.0067	.000134
38,104	400	.0091	.000182
47,630	500	.0116	.000232
57,156	600	.0141	.000282
66,682	700	.0165	.000330
76,208	800	.0191	.000382
85,734	900	.0215	.000430
95,260	1000	.0240	.000480
114,312	1200	.0290	.000580
133,364	1400	.0340	.000680
152,416	1600	.0389	.000778
171,468	1800	.0443	.000886
190,520	2000	.0495	.000990
209,572	2200	.0546	.001092
228,624	2400	.0601	.001202
247,676	2600	.0652	.001304
266,728	2800	.0705	.001410
285,780	3000	.0758	.001516
304,832	3200	.0811	.001622
323,884	3400	.0869	.001738
342,936	3600	.0932	.001864
361,988	3800	.1005	.002010
381,040	4000	.1077	.002154
400,092	4200	.1084	.002168
416,000	4367	<i>Ultimate strength</i>	

Failed by crushing at end.

PROBLEMS.

5. Find E of yellow pine from the dotted prolongation of curve III, and also from Table III.

6. In a post similar to that of Table III an increment of load amounting to

STRESS BEYOND THE ELASTIC LIMIT 29

500 pounds per square inch produced a deformation of 0.0146 inch in a gauged length of 50 inches. Find *E*. Ans. 1,710,000.

7. An old post of long-leaf yellow pine, tested at the Watertown Arsenal, was 9.43 inches by 9.35 inches, and was chamfered $\frac{1}{4}$ inch at each corner. Using the area to the nearest square inch, find the ultimate strength, the ultimate load being 528,400 pounds.

TABLE IV.

COMPRESSION TEST OF 1 : 2½ : 6 CONCRETE; AGE, 90 DAYS.

Diameter of test cylinder, 8 inches; area, 50 square inches.

Total length, 16 inches; gauged length, 10 inches.

Applied load.		Deformation.	
Total.	Per square inch.	In gauged length.	Per inch length.
Pounds.	Pounds.	Inch.	Inch.
2,000	40	0.00013	0.000013
4,000	80	.00026	.000026
6,000	120	.00038	.000038
8,000	160	.00052	.000052
10,000	200	.00068	.000068
12,000	240	.00081	.000081
14,000	280	.00099	.000099
16,000	320	.00113	.000113
18,000	360	.00136	.000136
20,000	400	.00158	.000158
22,000	440	.00180	.000180
24,000	480	.00206	.000206
26,000	520	.00232	.000232
28,000	560	.00260	.000260
30,000	600	.00295	.000295
32,000	640	.00327	.000327
34,000	680	.00377	.000377
36,000	720	.00421	.000421
38,000	760	.00473	.000473
40,000	800	.00535	.000535
42,000	840	.00609	.000609
44,000	880	.00692	.000692
46,000	920	.00796	.000796
48,000	960	.00922	.000922
50,000	1000	.01058	.001058
52,000	1080	.01177	.001177
54,000	1080	.01323	.001323
56,000	1120	.01575	.001575
58,000	1160	.01847	.001847
60,000	1200	<i>Failed</i>	

Fig. 10 gives some comparative curves for timber and concrete. Curve I is the long-leaf yellow pine of Table III. The

unit deformations are represented on a scale twice as great as in Fig. 9, and the unit stresses, by a scale ten times as great. Curve II of Fig. 10 is the stress diagram for a sample of 1:2.5:6 concrete in compression, the readings for which are given in Table IV.

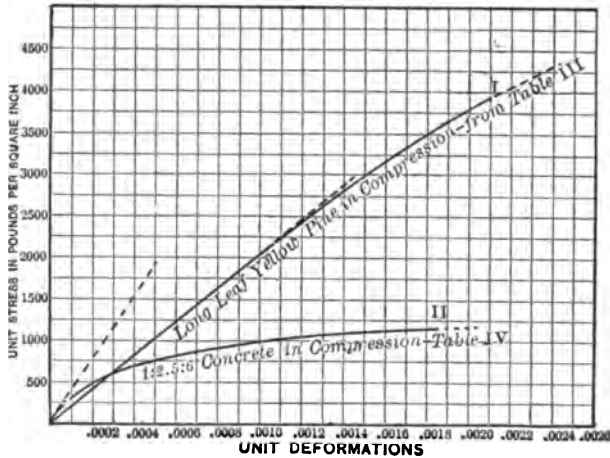

Fig. 10.

PROBLEMS.

8. Calculate the modulus of elasticity of concrete from the dotted prolongation of the curve in Fig. 10.

9. From the area included between the curve for timber in Fig. 10, the X axis, and the ordinate corresponding to a unit elongation 0.001, compute the work done per unit volume in producing this elongation.

23. **Factor of Safety.** — In Article 6, the allowable unit stress was defined as depending upon the judgment of some authority. These judgments are based on tests of materials such as those of Tables I to IV.

Working stresses should never exceed the true elastic limit. They are generally based on the ultimate strength of the material. The ratio of the ultimate strength of a given material to the allowable working stress is called the *factor of safety*.

PROBLEMS.

1. If the steel of Table I is used with a factor of safety of 5, what is the allowable unit stress?

2. If cast iron such as that of Table II is used with a factor of safety of 10 in tension, what is the allowable unit stress?

Ans. 2500 pounds per square inch.

3. A concrete pier 16 inches square carries a load of 75,000 pounds. Using Table IV, find the factor of safety. *Ans. 4.*

4. A steel structure is designed in accordance with the New York building laws. The steel used satisfies the minimum requirements of the Manufacturers' Standard Specifications for steel for bridges. What is the factor of safety? *Ans. 3.5.*

The value of the factor of safety which should be used depends upon a great number of conditions. Some of these are:

Repeated stresses slightly beyond the true elastic limit will finally cause failure, so that a body subjected to varying load should have its allowable stresses well below this limit. The greater the variation of stress, the smaller should be the allowable unit stress.

The factor of safety must be large enough to allow for any deterioration of the material from any cause during the time which it is to be used. This includes the decay of timber, the rusting of metal, the effect of frost and electrolysis.

In deciding what factor of safety to use, the uniformity of the material must be taken into account. Structural steel which has an ultimate strength of 65,000 pounds per square inch on an average will seldom vary 5000 pounds on either side of this figure; while the variation of timber sufficiently good to pass a reasonable inspection may be 50 per cent of the average ultimate strength. An engineer, in designing a concrete structure which he knows will be built under competent supervision, will use much higher unit stresses than he will risk where such inspection is wanting.

The factor of safety must also depend upon the amount of injury which would occur if the material failed. We would use a plank in a scaffold 3 feet high with a much lower factor of safety than we would consider if failure meant a fall of 100 feet.

The factor of safety must allow some margin for unexpected loads. Cases have occurred where a wagon bridge has failed when used as a grand stand to watch a boat race or fireworks. That part of the factor of safety which makes allowance for lack of ordinary judgment in persons using the machine or structure is called the "fool factor."

PROBLEM.

5. Taking the figures of the United States Department of Agriculture as correct, find the factor of safety of white oak and long-leaf yellow pine in compression, with the grain and across the grain, when used in accordance with the New York building laws.

24. **Effect of Form on the Ultimate Strength.** — We have assumed in our discussions that the stress across any section is uniform. This is true in a rod of uniform section at some distance from the surface of application of the load, provided that the line of resultant force coincides with the axis of the rod.

Test bars are made of uniform section throughout, or of uniform section for some distance beyond the extremities of the

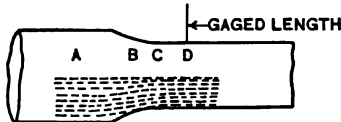

Fig. 11. — Stress Distribution in Test Bar.

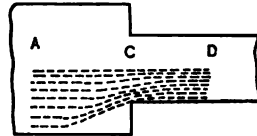

Fig. 12. — Abrupt Change of Section.

gauged length. (See Fig. 6, and also the form of test bar adopted by the Society for Testing Materials, as given in Cambria, under Manufacturers' Standard Specifications, or in the Proceedings of the Society.) Fig. 11 represents one end of such a bar. The stress which may be uniformly distributed across a section at *A* is unequally distributed at sections *B* and *C*, and becomes uniform and parallel to the axis at *D*. If the gauged length began at *C* at the beginning of the parallel portion, the measured elongation would be too high, owing to the fact that the stress is greater than the average near the surface. This effect would be increased if the change in section were abrupt as in Fig. 12.

The ultimate strength of a rod at such a change of section depends upon its ductility. If rods as in Fig. 12 are made of cast iron or other *nonductile* material, they will fail at section *C* owing to the concentration of stress near the surface. The more abrupt the change the greater the concentration and the easier the failure. If the rod is of *ductile material*, such as structural steel, the strength at *C* will be increased by the material of the larger section to the left. A ductile substance necks before it fails. The material of the larger section tends to prevent

necking in the smaller sections at a considerable distance to the right of *C*.

A rod of ductile material with a short reduced area, such as I and II, Fig. 13, will show a considerably higher ultimate strength than a rod in which the minimum section is longer, as in III, Fig. 13.

It is not necessary to make test bars of the form shown in Fig. 6; any bar of uniform section will do, and many tests are made of such bars as they come from the rolls. There is this advantage in the standard form shown in Fig. 6, — that it will fail inside the gauged length on account of the resistance to necking for some distance from the larger section. A bar of uniform section may fail outside of the gauged length.

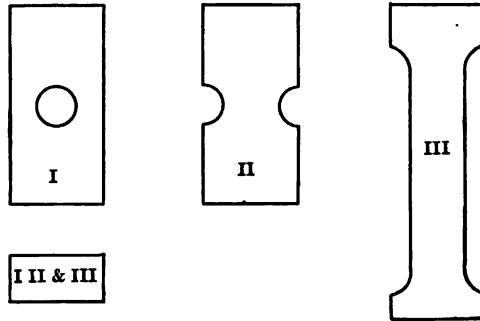

Fig. 13. — Reduced Sections.

It is hardly necessary to state that all changes in section should be gradual. The standard form of bar, as adopted by the Society for Testing Materials, changes from large to small section on the arc of a circle tangent to the surface of the smaller section. It is easier to make a *taper* from one size to the other, and the results are practically as good.

25. Effect of Stresses beyond the Yield Point. — In materials which are not ductile, any stress beyond the elastic limit produces a permanent injury. In ductile materials, especially soft iron and steel, this is not the case. If a rod of steel or iron, originally hot-rolled, is stressed beyond the yield point, the result is a raising of the yield point. If a rod having a yield point of 35,000 pounds is carried up to 50,000 pounds, producing a large permanent set, upon testing the second time the yield point will be found to be about 50,000 pounds. When a high elastic limit

and yield point are desired, soft steel is subjected to cold-rolling. The effect of this is to raise the yield point to nearly the ultimate strength of the steel. The ultimate strength is also raised considerably in terms of the *original cold-rolled* section. Cold-drawing as employed in the manufacture of wire has a similar effect.

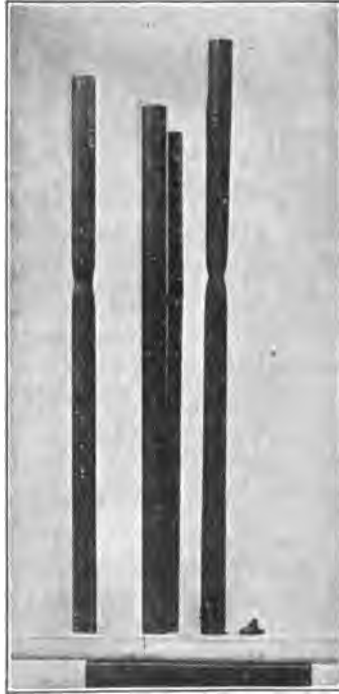

Fig. 14. — Soft Steel in Tension; Left, Cold-Rolled; Right, Annealed.

Fig. 14 and Table V show the effect of cold-rolling. In Fig. 14 the middle rod is a piece of nominal $\frac{1}{2}$ -inch cold-rolled shafting. The left rod is an exactly similar one after testing in tension. Its ultimate strength was over 86,000 pounds per square inch and its elongation practically 10 per cent. On the right is a third rod, originally like the others, which was annealed by heating to redness and cooling slowly to destroy the effect of the previous cold-rolling. When tested in tension its ultimate strength was found to be 60,000 pounds per square inch and its elongation 22 per cent.

TABLE V.

TENSILE TEST OF SOFT STEEL; COLD-ROLLED, AND ANNEALED.

Diameter of rods, 0.874 inch; area, 0.600 square inch; gauged length, 8 inches.

Total load in pounds.	Unit elongation.	
	Cold-rolled rod.	Annealed rod.
	inch	inch
3,000	0.000163	0.000175
6,000	.000356	.000356
9,000	.000512	.000525
12,000	.000681	.000712
15,000	.000861	.000894
18,000	.00102	.00106
21,000	.00118	.00122
22,20000177
22,80000217
22,20000231
22,80000245
23,40000480
24,000	.00132	.00750
27,000	.00150	.034
30,000	.00166	.050
33,000	.00184	.081
36,000	.00202	.164
35,200189
33,000201
28,000219
39,000	.00223	
42,000	.00264	
45,000	.00326	
48,000	.00570	
49,500	.00739	
47,000	.00775	
49,000	.01045	
49,500	.01502	
50,000	.01895	
51,000	.02970	
51,900	.054	
51,100	.067	
48,000	.079	
45,000	.085	
39,000	.099	

Diameter of neck at fracture was 0.640 inch in cold-rolled rod and 0.570 inch in annealed rod. Analysis: carbon, 0.113 per cent; manganese, 0.495 per cent.

PROBLEMS.

1. From Table V find E for each rod from the 15,000-, 18,000-, and 21,000-pound loads.
2. Plot curve for each on same sheet to a suitable scale. Plot part of each curve to a scale with abscissas enlarged twenty-fold and determine E . Calculate the apparent and actual unit stress in the neck at rupture for each case.

The fact that soft steel may be stressed beyond the yield point without injury, and with no change except a slight reduction of section and elevation of the yield point, is of great advantage in its use in structures. In a heavy structure made of many parts, there is always some adjustment when the loads are first applied. This may cause an overstraining of some parts. If these parts are made of soft steel, they can yield slightly, permitting other members to take part of the excess load.

Chapter XIX gives additional information in regard to the effect of stress beyond the yield point and the nature of the stress-strain diagram of steel.

Lewis P. McGilvary
Elect. Eng. 1916

CHAPTER III.

SHEAR.

26. **Shear and Shearing Stress.** — We have learned that when a body is subjected to a pair of forces in the *same line*, *tensile stress* is produced, if the forces are directed away from each other, and *compressive stress*, if they are directed towards each other.

If the forces are in *parallel lines* or planes, *shearing* and bending stresses are produced in the portion of the body between the planes of the forces. In Fig. 15, the block *A* is securely held by the body *B* and a horizontal force *P* is applied by a second body *C*. This force *P* is parallel to the upper surface of *B*. The body *B* exerts a horizontal force on the block which is equal and opposite to the force in *C*. If we consider that portion of the block *A* between the plane of the upper surface of *B* and the plane *EFG* of the lower surface of *C*, we find that it is subjected to a pair of equal and opposite forces. The material of this portion of the block is subjected to *shearing* and *bending* stresses. The shearing stresses depend upon the magnitude of the forces and the area of the section of *A*. The bending stresses depend upon these and also upon the distance of the forces apart. If the body *C* is brought very close to *B*, so that the distance between the two forces *P* and *P'* becomes negligible, the unit bending stress becomes small, while the unit shearing stress is unchanged. The average unit shearing stress is calculated by dividing the force *P* by the area of the cross section *EFG* or the area of any section parallel to it. We notice that in tension or compression we divide the total force by the area of the cross section *perpendicular* to its direction to get the unit stress; while in shear we divide the total force by the area of the cross section *parallel* to the forces and *perpendicular* to the plane which includes the two sets of forces.

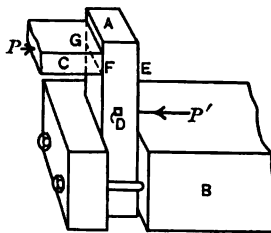

Fig. 15. — Shear and Bending.

In this, as in all other cases, the line P in the drawing represents the resultant of a set of forces distributed over an area. The resultant P' must fall some distance below the upper surface of B , and the resultant P must be above the lower surface of C . It is, therefore, not convenient by this method to get shearing stress entirely free from bending or compressive stress. We will find later that the distribution of shearing stress, when combined with bending, is not uniform over the section; but for the present we shall take no account of this variation, and shall calculate the average shearing stress by dividing force by area.

PROBLEMS.

1. A 1-inch round rod projects horizontally from a wall. A ring hung on the rod supports a load of 5000 pounds. Find the average unit shearing stress.

Ans. 6366 pounds per square inch.

2. A bar 1 inch wide and $\frac{1}{4}$ inch thick rests upon two supports and carries a load of 400 pounds midway between them. Find the mean unit shearing stress.

3. A 4-inch by 4-inch wooden block has a notch 2 inches deep cut in one side, the edge of the notch being 6 inches from one end of the block. A pull of 1800 pounds parallel to its length is applied by means of a second block set in the notch. Find the unit shearing stress.

Ans. 75 pounds per square inch.

4. If, in Problem 3, the grain is parallel to the length, what is the greatest allowable pull for an oak block?

Ans. 4800 pounds.

5. Solve Problem 4 for long-leaf yellow pine and for hemlock. State your authority for allowable unit stresses.

6. A 2-inch by 4-inch long-leaf yellow-pine block, hung vertical and supported at the upper end, has a hole 1 inch square perpendicular to the 4-inch face. The lower edge of this hole is $4\frac{1}{2}$ inches from the lower end of the block. If a load of 1800 pounds is hung on a rod passing through this hole, what is the unit shearing stress in the timber? What is the mean unit shearing stress in the rod if the load is symmetrical (Fig. 16)?

Ans. 100 pounds per square inch;
900 pounds per square inch.

7. The head of a 1-inch bolt is $\frac{1}{4}$ inch thick. Find the mean unit shearing stress tending to strip the head from the bolt when subjected to a pull of 10,000 pounds.

Ans. 3640 pounds per square inch.

8. In Problem 7, what is the unit tensile stress in the weakest part of the bolt if the pull is applied by means of a nut?

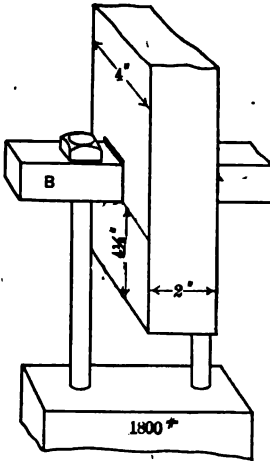

Fig. 16. — Shear in Timber.

27. **Shearing Deformations.** — Consider a portion D of block A of Fig. 15. The portion extends through the block with its long dimension perpendicular to the plane which contains the resultants P and P' . It is represented on an enlarged scale by the rectangle $HIJK$, Fig. 17. When the shearing forces are applied as shown in Fig. 15, it is distorted to the form $HI'J'K$. If we regard HK as fixed, the total displacement of any point in the upper line is equal to II' or JJ' . The *unit deformation* is the ratio of this *horizontal displacement*, II' , to the vertical distance, HI . The unit shear is the tangent of the angle IHI' or JKJ' . The effect of the shearing forces is to lengthen the diagonal HJ , and shorten the diagonal IK .

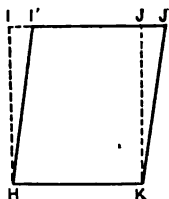

Fig. 17. — Shearing Deformations.

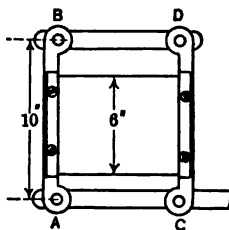

Fig. 18.

PROBLEMS.

1. Two equal bars, AB and CD , Fig. 18, are hinged to a second pair of equal bars, AC and BD , to form a parallelogram. A sheet of rubber 6 inches wide has one edge securely clamped to AB and the other edge to CD . The length of AB , center to center of hinges, is 10 inches. What is the unit shear when B is displaced 0.2 inch to the right of the vertical from its original vertical position?

Ans. Unit shear, 0.02.

2. A hollow circular shaft 5 inches in diameter is subjected to a twisting moment, and it is found that two sections 10 feet apart suffer a relative displacement of 2 degrees. What is the total shearing displacement of the fibers? What is the unit displacement?

Ans. { Total displacement, 0.0873 inch;
Unit displacement, 0.00073.

28. **Modulus of Elasticity in Shear.** — The modulus of elasticity in shear is obtained by dividing unit shearing stress by unit shearing deformation, just as the modulus of elasticity in tension or compression is computed by dividing unit stress by unit deformation. The modulus of elasticity in shear is also called the modulus of rigidity. In formulas it is represented by E_s , when it is desirable to distinguish it from the modulus in

tension or compression. The latter may be represented by E_t and E_c , respectively. Forces applied as in Fig. 15 do not give pure shearing stress. It is only in the case of torsion, as in Problem 2 of Article 27, that we get pure shear.

PROBLEMS.

1. In Problem 2 of Article 27, if E_s equals 11,000,000, what is the unit shearing stress? *Ans.* 8030 pounds per square inch.
2. If the modulus of elasticity in shear in a given 4-inch circular shaft is 10,500,000, what is the maximum allowable unit shear, if the allowable unit shearing stress is 9000 pounds per square inch? *Ans.* 0.000857.
3. In Problem 2, what is the maximum angle of twist in a length of 5 feet?

MISCELLANEOUS PROBLEMS.

1. In Fig. 19, A and B are short compression members or struts of yellow pine, joined together at the top by a bolt or pin and held from spreading at

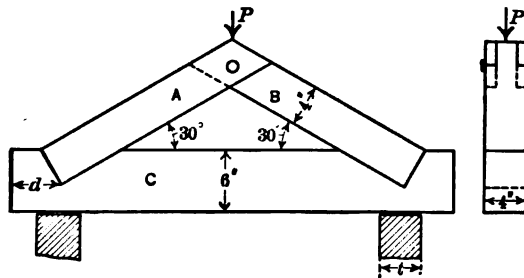

Fig. 19.

the bottom by being set into the notches in the bottom chord C . If the load P is 6000 pounds, what is the unit compressive stress in A and B ? What is the maximum unit tensile stress in C ? What must be the length of the section d to avoid shearing, if C is made of oak? *Ans.* Length of d , 6.5 inches.

2. In Problem 1, what must be the thickness of the supports upon which C rests; (a) if made of limestone; (b) if made of Douglas fir parallel to the grain? (c) if made of Douglas fir with load perpendicular to the grain?

3. What is the force required to punch a $\frac{3}{4}$ -inch hole in a $\frac{1}{2}$ -inch steel plate if the ultimate shearing strength of the plate is 40,000 pounds per square inch?

4. In Problem 3, what is the unit compressive stress in the punch?

5. A set of punches are made of steel having a compressive strength of 150,000 pounds per square inch and are used to punch steel with a unit shearing strength of 40,000 pounds per square inch. What is the smallest hole which can be punched in a $\frac{1}{2}$ -inch plate? *Ans.* 0.8 inch diameter.

6. If s_c is the compressive strength of the punch, and s_s the shearing strength of the plate, derive the formula which will express the relation between the thickness of the plate and the diameter of the smallest hole which can be safely punched.

29. Shear Caused by Compression or Tension. — Fig. 20 represents a block subjected to a compressive force P in the direction of its length and an equal reaction at the bottom. Imagine the block cut by a plane normal to its length and glued together again. If we consider the portion of the block above the section $BCDE$ as a free body and resolve vertically, we have the force P acting downwards equal to the upward reaction of the glued surface. (Neglect the weight of the portion above $BCDE$.) If A is the area of the glued surface, the unit compressive stress is given by

$$s_c = \frac{P}{A}.$$

If we resolve horizontally, that is, parallel to any line in $BCDE$, all the components of the external force are zero and the unit shearing stress is zero. If the body was actually made of two portions, the upper portion would not slide on the lower portion, no matter how smooth the surfaces of contact might be.

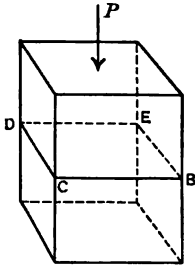

Fig. 20. — Section Normal to Force.

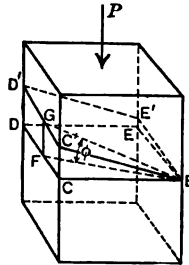

Fig. 21. — Section Inclined to Force.

Now consider a similar body, Fig. 21, cut by a plane $BC'D'E'$ which makes an angle ϕ with the normal plane. Taking the portion above the plane as a free body, as before, we will resolve the external force P perpendicular and parallel to the plane. The total perpendicular component is $P \cos \phi$, and the unit compressive stress is this component divided by the area of the section. If A is the area of the normal section $BCDE$, the area of the inclined section is $A \sec \phi$.

$$\text{Unit compressive stress} = \frac{P \cos \phi}{A \sec \phi} = \frac{P}{A} \cos^2 \phi. \quad (1)$$

Resolving parallel to the line BG , which makes the maximum angle with the normal plane, the component of P is equal to

$P \sin \phi$. The unit shearing stress is this component divided by the area of the inclined section.

$$s_s = \frac{P \sin \phi}{A \sec \phi} = \frac{P}{A} \sin \phi \cos \phi = \frac{P}{2A} \sin 2\phi. \quad (2)$$

The same relations hold for tension and compression.

PROBLEMS.

1. Show from equations (1) and (2) that shearing stress is zero and compressive stress a maximum when ϕ is zero.
2. A 2-inch by 2-inch block is subjected to a compressive force of 1800 pounds in the direction of its length. Find the unit compressive and unit shearing stresses with respect to a plane making an angle of 20 degrees with the normal cross section.
Ans. $\begin{cases} s_c, 397 \text{ pounds per square inch;} \\ s_s, 145 \text{ pounds per square inch.} \end{cases}$
3. A 4-inch by 4-inch long-leaf yellow-pine post has the grain 15 degrees with its axis. What is the total safe load considering the shear parallel to the grain, using the values recommended by the Association of Railway Superintendents of Buildings and Bridges? *Ans.* 9600 pounds.
4. Prove that the unit shearing stress produced by a single tensile or compressive load is a maximum at 45 degrees with the direction of the load, and that the maximum unit shearing stress is one-half of the compressive or tensile stress.

30. Shearing Forces in Pairs. — Shearing forces applied as in Fig. 15 do not give pure shearing stress. If we consider the block shown in vertical section in Fig. 22, the force P at the left

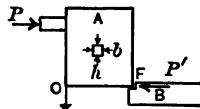

Fig. 22.

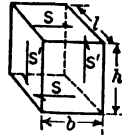

Fig. 23. — Equilibrium in Shear.

will turn it over, unless it is held down at C or at some other point to the left of F . If it is held down at C , there is an equal and opposite force at F , the two forces at C and F forming a couple of moment equal to that of the horizontal forces P and P' . Take a small block of rectangular section, of height h and breadth b , running through the large block A perpendicular to the plane of the paper (Figs. 22, 23). Let l be the length of this small block perpendicular to the plane of the paper in Fig. 22, and perpendicular to the planes of all the applied forces. The top and bottom surfaces have areas bl each. The area of the left vertical surface is hl . Let there be a shearing force of s pounds

per square inch directed towards the right in the upper surface, and a stress of equal intensity in the lower surface directed towards the left. The *total* shearing force in each of these surfaces is sbl , and the moment of the couple tending to turn the block in a clockwise direction is the product of one of these total forces multiplied by the distance between their planes, or $sblh$. If the block is subjected to shearing forces only, there must be a shear downward at the left surface and a shear upward at the right surface, to prevent rotation. If s' is the intensity of one of these vertical shearing stresses, the total force on each of these vertical surfaces is the product of s' multiplied by the area hl ; and the moment is $s'hlb$. The moments of the horizontal and vertical forces are equal, if the block is in equilibrium.

$$sblh = s'hlb, \quad s = s'. \quad \text{Formula III.}$$

When a body or portion of a body is subjected to *pure* shearing stresses, these stresses occur in pairs at right angles to each other, and the *unit shearing stress* is the same in both pairs.

If forces are applied to a block as in Fig. 22, with a downward pull at C , and an upward push at F , a small block of section bh will be subjected to pure shear if it is in the vertical plane midway between C and F . If the small block is located to the left of the middle, there will be shear combined with tension. If it is on the right side, there will be shear and compression.

31. Compressive and Tensile Stress Caused by Shear. — Fig. 24 I, represents a rectangular parallelepiped of breadth b , height h , and length l , subjected to *pure* shearing stress. The shearing stress acts toward the right parallel to the breadth at the top and toward the left at the bottom. As shown in Article 30, there is also a shearing stress of the same intensity at the left surface acting downward and an equal shearing stress at the right surface acting upward. (If the direction of one of these shears is reversed, they must all be reversed to produce equilibrium.) Now consider the parallelepiped

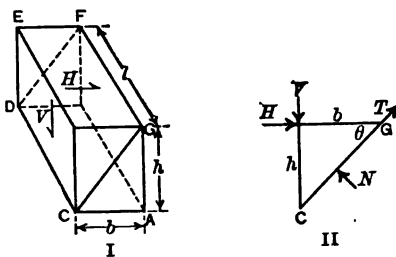

Fig. 24. — Shear Causing Compression.

divided by the inclined plane containing the edges CD and GF , and treat the triangular prism to the left of this plane as a free body in equilibrium under the action of the forces at its surface. These forces are four in number: the shearing force H in the upper surface acting toward the right, the shearing force V in the left vertical surface acting downward, the compressive force N acting normal to the inclined surface (Fig. 24, II, which represents all the forces in the plane of the paper), and a shearing force T along this surface parallel to the diagonal line CG . If s_s is the intensity of the horizontal and vertical shear,

$$H = s_s bl, \quad V = s_s hl.$$

Resolving normal to the inclined plane,

$$N = H \sin \theta + V \cos \theta, \quad (1)$$

$$N = s_s bl \sin \theta + s_s hl \cos \theta, \quad (2)$$

where θ is the angle which the inclined plane makes with the horizontal surface. Since

$$\tan \theta = \frac{h}{b},$$

$$N = 2 s_s bl \sin \theta. \quad (3)$$

To get the unit compressive stress, s_c , across the inclined surface, divide the total compression N by the area of the surface $bl \sec \theta$:

$$s_c = 2 s_s \sin \theta \cos \theta = s_s \sin 2 \theta. \quad (4)$$

When θ is 45 degrees, we get the maximum value of the compressive stress,

$$s_c = s_s. \quad \text{Formula IV.}$$

In like manner, if we consider a second inclined plane perpendicular to CG and parallel to CD , we get a tensile stress of the same value.

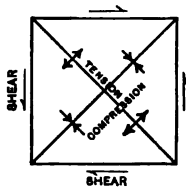

Fig. 25.

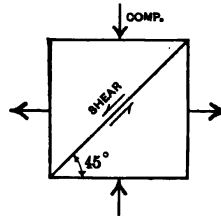

Fig. 26.

When a body is subjected to pure shear, there is a compressive stress of equal intensity across planes at 45 degrees to the direc-

tion of the shearing stresses, and tensile stresses of the same intensity across planes at 45 degrees to the shearing planes in the opposite directions. This is shown in Fig. 25.

PROBLEMS.

→ 1. Prove that a block, subjected to a compressive stress of intensity s and a tensile stress of the same intensity at right angles, has a shearing stress of the same intensity at 45 degrees and 135 degrees (Fig. 26).

→ 2. A 2-inch by 2-inch block is cut at an angle of 14 degrees and glued together again. If a pull of 400 pounds is applied parallel to its length (at 14 degrees with the glued section), what is the unit shearing stress in the glue? what is the unit tensile stress in the glue?

Ans. $\begin{cases} s_s, 23.5 \text{ pounds per square inch;} \\ s_t, 5.85 \text{ pounds per square inch.} \end{cases}$

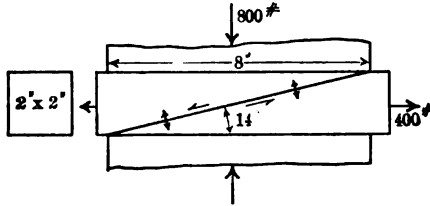

Fig. 27.

→ 3. If a compressive force of 800 pounds is applied transversely to a length of 8 inches of the block of Problem 2 (Fig. 27), while the longitudinal stress is acting, find the unit shearing and normal stress in the glue.

Ans. $\begin{cases} s_s, 35.2 \text{ pounds per square inch;} \\ s_c, 41.1 \text{ pounds per square inch.} \end{cases}$

4. Solve Problem 3, if the 400 pounds is changed to compression.

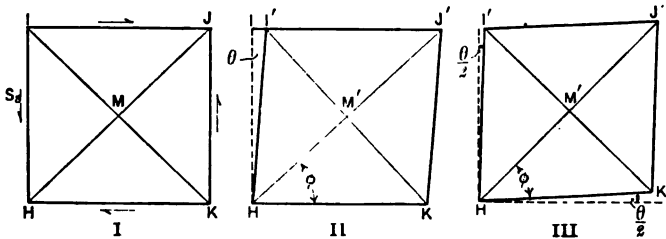

Fig. 28. — Shearing Deformation.

The modulus of shearing elasticity may be calculated from the modulus in tension or compression if Poisson's ratio is known.

Fig. 28 is the front elevation of a block of square section subjected to shearing forces. The unit shearing displacement is the tangent of the angle θ between the lines IH and $I'H$ of Fig. 28, II. In Fig. 28, III, we have kept the

directions of the diagonals constant instead of the base line, as in II, so that the line HK' makes an angle $\frac{\theta}{2}$ with the horizontal, and the line HI' makes an equal angle with the vertical. We will determine the magnitude of this angle $\frac{\theta}{2}$.

When the shearing force acts on the body, the diagonal HJ is lengthened to HJ' and the diagonal IK is shortened to $I'K'$. The half-diagonals HM and MK , originally equal, suffer a proportional deformation.

If δ is the unit linear deformation due to a unit direct stress s , the unit deformation along the diagonal HJ' is $\delta(1 + \rho)$. This is made up of the elongation δ due to the tension along this diagonal and the elongation $\rho\delta$ due to the equal compression along the other diagonal. In a similar way the unit deformation along the diagonal $I'K'$ is $-\delta(1 + \rho)$.

The tangent of the angle ϕ which the line HK' (Fig. 28, III) makes with the diagonal is given by:

$$\tan \phi = \frac{M'K'}{HM'} = \frac{MK[1 - \delta(1 + \rho)]}{HM[1 + \delta(1 + \rho)]} = \frac{1 - \delta(1 + \rho)}{1 + \delta(1 + \rho)}$$

To get the angle $\frac{\theta}{2}$ we will subtract the angle ϕ from 45 degrees.

$$\tan \frac{\theta}{2} = \frac{\tan 45^\circ - \tan \phi}{1 + \tan 45^\circ \tan \phi} = \delta(1 + \rho)$$

$$\text{For small angles, } \tan \theta = 2 \tan \frac{\theta}{2} = 2\delta(1 + \rho)$$

$$\text{Since } \delta = \frac{s}{E},$$

$$\tan \theta = \frac{2s(1 + \rho)}{E},$$

$$E_s = \frac{s}{\tan \theta} = \frac{E}{2(1 + \rho)}$$

$$\text{When } \rho = \frac{1}{4}, \quad E_s = \frac{2E}{5}$$

PROBLEMS.

5. If E for steel is 29,000,000 and Poisson's ratio is 0.27, find the modulus of shearing elasticity. Ans. $E_s = 11,400,000$.
 6. If E is 30,000,000 and E_s is 11,600,000, find Poisson's ratio.

32. Methods of Failure.— We have shown the method of failure of soft steel in tension. It necks and finally breaks normal to the length. One portion is slightly concave, especially at the outside, showing that the final failure here is by shearing. A rod of hard steel will sometimes shear off at nearly 45 degrees with the direction of its length. In Article 29 we found that a tensile or compressive stress produces a shearing stress which has its maximum value at 45 degrees, at which direction it is one-half

the direct stress. If any material is less than half as strong at 45 degrees in shear as it is in tension or compression in the direction of the stress, it will fail by shear. As the shearing stress varies slowly near 45 degrees, the direction of failure may differ considerably from that angle. If the shearing strength at 30 degrees or at 60 degrees is less than 86 per cent of the strength at 45 degrees, failure may occur along one of these directions. Timber has a small shearing strength parallel to the growth rings and a larger strength at right angles to them. Fig. 29 shows a small piece of timber which was tested in tension. The lines of fracture are oblique, the shear taking place first in one direction and then in the other.

In compression, materials which are not ductile may fail by shearing at about 45 degrees with the direction of the stress or by splitting longitudinally. The shearing takes place as in tension when the unit compressive stress exceeds twice the unit shearing strength at 45 degrees; the splitting longitudinally depends upon the relative values of the compressive strength in the direction of the length, the tensile strength normal to the length, and Poisson's ratio. For instance, if Poisson's ratio for concrete is 0.2, a unit compressive stress of 2000 pounds per square inch will cause a unit tensile stress of 400 pounds per square inch, provided the moduli of elasticity in tension and compression are the same. Under such conditions concrete may fail by tension. If the concrete is tested by compression between steel plates in the testing machine, the friction of the plates tends to prevent expansion at the ends. Fig. 30 shows the behavior of two 4-inch by 4-inch blocks of 1:1 cement mortar under a compressive load parallel to the long dimension. Both failed by splitting lengthwise, and both sheared to form a pyramid-shaped block at one end. Cement and stone cubes usually fail by shear. Fig. 31 shows the failure of two paving bricks in compression.



Fig. 29. — Timber in Tension.

In Fig. 32 the short block illustrates shear. Only short blocks of very uniform structure will fail in this way (by shear entirely across the section in one plane). Most blocks fail by a combi-

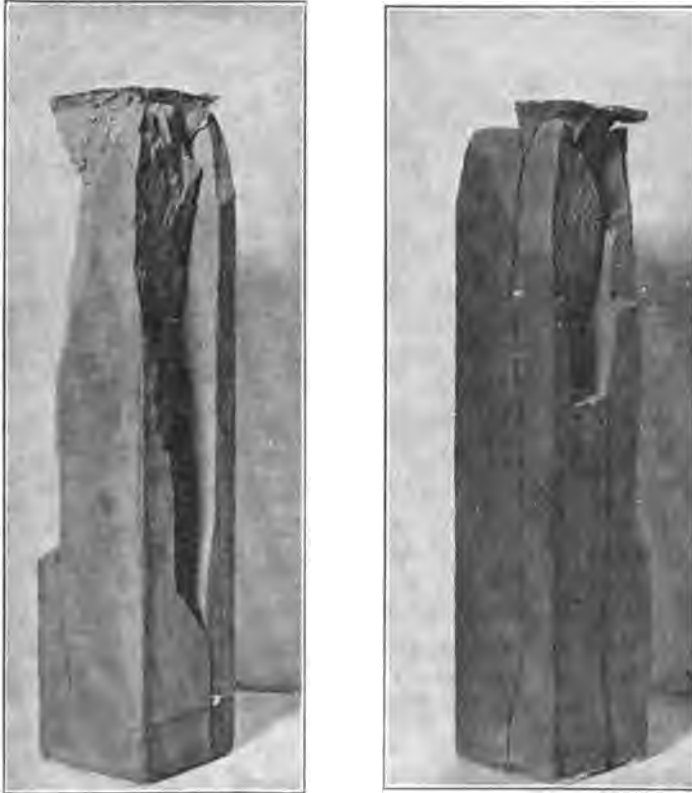

Fig. 30. — Cement in Compression.

nation of shear and splitting, as shown in the other cases. In fact, all of these are selected samples. Generally the shear planes will run for only a short distance and then split or run the other way.

PROBLEMS.

1. The white-oak block on the right in Fig. 32 was originally 1.83 inches by 1.82 inches. The ultimate load was 19,314 pounds. What was the unit shearing stress at 45 degrees to the normal section? what was it at 35 degrees and at 55 degrees to that section?

- > 2. A white-oak block 1.8 inches square was cut so that the growth rings made an angle of 10 degrees with the plane of the ends. When tested in compression it failed by shearing along the growth rings under a load of 4700 pounds. What was the unit shearing strength parallel to the grain?

Plastic material in compression may expand almost indefinitely under compression. If less plastic, there is considerable expansion and longitudinal splitting.

Fig. 33 shows two pieces of wrought-iron tubing which failed in this way. A solid rod, unless very short, with the resultant force exactly central, will fail by bending, as in the left of Fig. 33. If too short to bend it will expand indefinitely.



Fig. 31. — Hard Brick in Compression.

33. Bearing Strength; Failure by Cutting.— The bearing strength of a solid depends upon the relative size of the surface of contact and the entire dimensions of the body. In the treatment of bearing stress, there are two limiting cases. The first is that shown in Fig. 34, in which the surface of contact is equal to the entire cross section of the body *B*, and the length in the direction of the applied force is at least equal to the thickness of the body. In this case the bearing strength is equal to the compressive strength. Used in this way, a soft material like babbitt metal would have little bearing strength. Fig. 35 shows the second case. Here the load is applied to a small portion of a body which is of unlimited extent or is confined laterally by

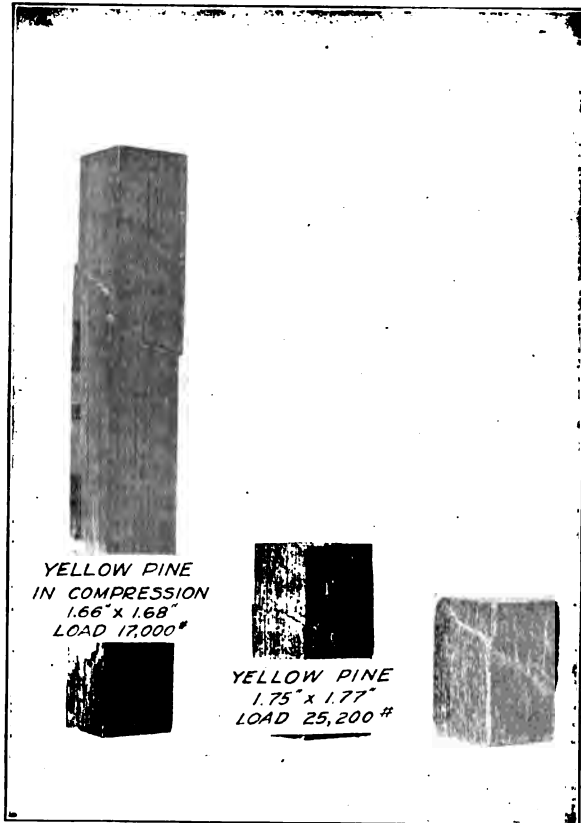

Fig. 32. — Timber in Compression.



Fig. 33. — Metal in Compression.

another body. The portion outside of the loaded area acts as a hoop to prevent the lateral expansion. In this form, a body composed of *separate particles* may have considerable bearing strength, depending upon the friction. Dry sand is an example.

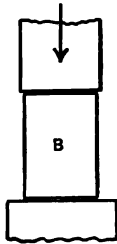

Fig. 34.

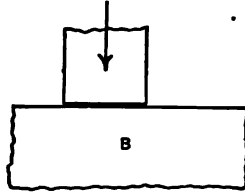

Fig. 35.

In a mass of wheat or flaxseed, where the friction is smaller, the bearing strength is less.

Fig. 36 shows two cases intermediate between Figs. 34 and 35.

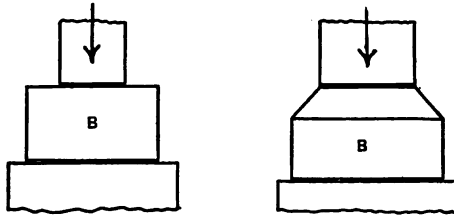

Fig. 36.

Cutting with a knife or chisel depends upon the bearing strength of the tool and of the material cut. The bearing strength of the tool under the conditions of Fig. 34 must be greater than

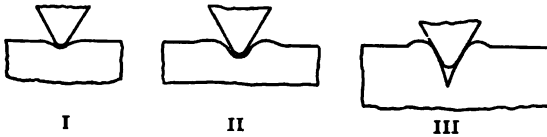

Fig. 37. — Cutting.

that of the material under the conditions of Fig. 35. At first there is a depression in the material under the edge of the tool, as shown in Fig. 37, I. When the stress in the material passes the bearing strength, it is permanently pushed back. In a plas-

tic nonporous material, some of the substance is forced up by the pressure, as shown in Fig. 37, II. In a porous body like wood there is an increase in density adjacent to the cutting surface. The wheel of a wagon cutting in soft earth illustrates both cases. If the earth is wet clay, we have an illustration of the plastic nonporous substance; if it is dry loam, it approaches the other case.

When a cutting tool has penetrated a little distance, it acts as a wedge and exerts a tensile stress upon the material in front of its edge. This is shown in Fig. 37, III.

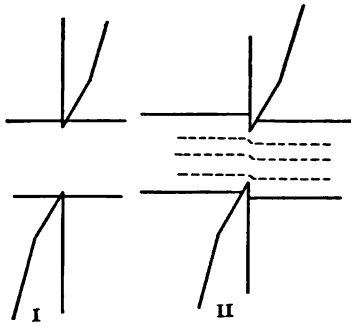

Fig. 38. — Cutting with Shears.

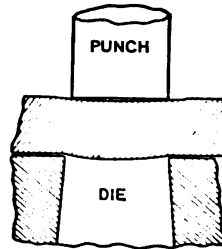

Fig. 39.

Fig. 38 shows the behavior of a pair of scissors or shears. At the beginning, the cutting is due to the bearing stress on the cutting edges, as shown in Fig. 38, I. As the edges penetrate

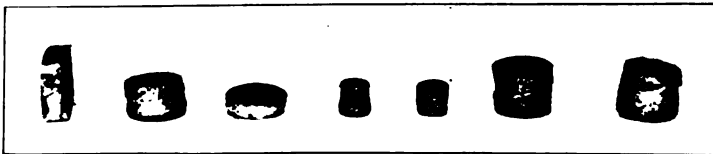

Fig. 40. — Slugs Punched from Steel Plates.

into the material the bearing force is increased at each blade. These forces produce shearing stresses in all portions of the body in the plane of the cutting edges. The corresponding shearing deformations are shown by the dotted lines in Fig. 38, II. Fig. 39 represents the punching of a metal plate. The plate is bent a little at first, which makes the surface of contact a narrow ring at the edge of the punch and die. When the compressive

stress on these rings exceeds the bearing strength of the plate, cutting begins. This is followed by shear, as in the case of cutting with scissors.

Fig. 40 shows some of the slugs punched from steel plates. Notice the curvature at the ends. In the case of the small diameter compared with the length, the punch failed after making about a dozen holes.

10-6

Lewis P. McGilvary
Elect. Eng. 1916

CHAPTER IV.
RIVETED JOINTS.

34. **Kinds of Stress.** — Riveted joints afford an excellent illustration of tension, compression, and shear, and of the manner of transmission of stress. Fig. 41 represents a pair of plates, each of breadth b and thickness t , transmitting a pull P in the

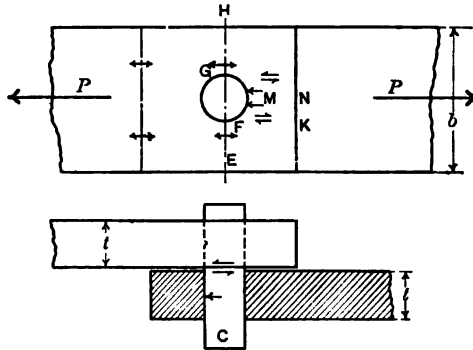

Fig. 41. — Stress at a Bolted Joint.

direction of their length. The plates are united by means of a pin C , which fits tightly in a hole in the lower plate and passes through a hole in the upper plate. If we consider the upper plate, we find that the portion to the left of the pin is in tension. The intensity of this tensile stress is found by dividing the pull P by the area bt . At the section EH in the plane of the center of the hole, the stress is still tension. The unit stress is greater here, for the area of cross section is diminished by the material cut away to make room for the pin. If the hole is in the middle of the section and in the line of the pull, half of the total stress is transmitted by the lower section EF and half by the upper section GH . The total stress which passes EF as tension passes FK as shear. The intensity of this shearing stress in the plate may be calculated by dividing the pull, $\frac{P}{2}$, by the section of length FK and thickness t . At M , the surface

of contact of the pin and plate, the stress is compression. The force is transmitted as a shearing stress from the part of the pin in the upper plate to the portion in the lower plate, and finally as compression to the lower plate.

It helps to fix our ideas if we regard stress as flowing like an electric current. This is illustrated in Fig. 42. We may regard

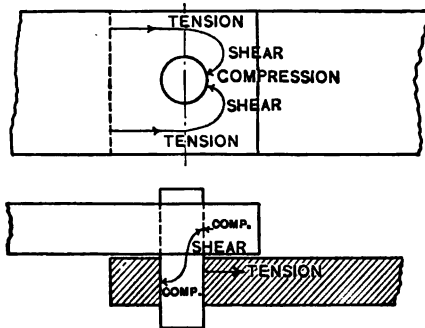

Fig. 42. — Flow of Stress.

the circuit as closed through the bodies which exert the pull on the plates.

PROBLEMS.

1. The plates in Fig. 41 are each 2 inches wide and $\frac{1}{2}$ inch thick. The hole in the upper plate is $\frac{1}{2}$ inch in diameter and that in the lower plate is $\frac{3}{4}$ inch in diameter. The bolt is $\frac{3}{4}$ inch in diameter. The pull is 4000 pounds. Find the unit shearing stress in the bolt and the maximum tensile stress in each plate.

Ans. $\left\{ \begin{array}{l} s_s, 9054 \text{ pounds per square inch;} \\ s_t, 7111, 6400 \text{ pounds per square inch.} \end{array} \right.$

2. In Fig. 41 the bolt is $\frac{3}{4}$ inch in diameter and exactly fits in the lower plate. The lower plate is 2 inches wide. What must be its thickness in order that the maximum unit tensile stress shall be equal to the unit shearing stress in the bolt joining the plates?

In calculating the unit shearing stress in the plates behind the bolt or pin, since there is some uncertainty as to the width of the bearing surface at *M*, it is customary to take the distance *MN* instead of *FK* in getting the shear area.

PROBLEM.

3. In Problem 1 find the unit stress in shear in the upper plate to the right of the pin, if the center of the hole is 1.5 inches from the edge of the plate.

Ans. 3765 pounds per square inch.

35. **Bearing Stress.** — In calculating the unit bearing or compressive stress at the surface of contact of the pin and plate, it is customary to regard the bearing area as the product of the thickness of the plate multiplied by the diameter of the pin. If d is the diameter of the pin and t is the thickness of the plate, the bearing area is td . In other words, it is the projection upon a plane parallel to the axis of the pin of that portion of the pin which is inside of the plate. Consider Fig. 43, in which a rec-

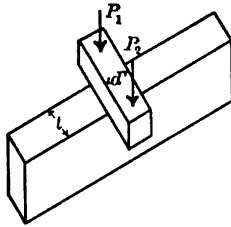

Fig. 43. — Bearing.

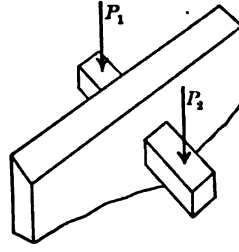

Fig. 44. — Bearing.

tangular bar of thickness d is placed across the edge of a plate of thickness t . If the bar crosses the plate at right angles, it is plain that the area of contact is td . If, as in Fig. 44, the bar passes through a hole in the plate, the bearing area is the same; and if the forces P_1 , P_2 are balanced with respect to the center of the plate, the bearing stress is uniform over the entire

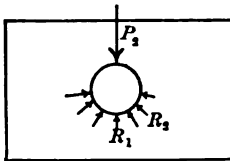

Fig. 45. — Bearing.

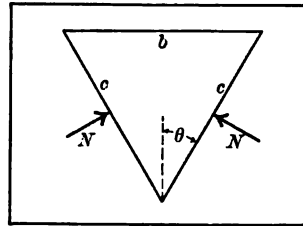

Fig. 46. — Bearing.

area. If the forces are not balanced, the area remains the same and the average bearing stress is the same, but the maximum stress is greater. If there is force on only one side of the plate, the maximum bearing stress will be less the smaller the distance between the force and plate. In Fig. 45 we have a round pin or bolt passing through a plate. The actual area is the lower half of the surface of the cylinder, of length t and

diameter d . The reactions R_1, R_2 , etc., are not all vertical, but are nearly normal to the surface of contact. If, as in the case of liquid pressure, these reactions were exactly normal and of equal intensity, the resultant of their vertical components would be the same as if that unit pressure were exerted on the horizontal projection of this cylindrical surface.

Consider a rivet in the form of an isosceles triangle of base b and equal sides c (Fig. 46), subjected to a load P perpendicular to the side b . If θ is one-half of the angle opposite b and N is the resultant normal force on one side c , we have by vertical resolutions:

$$2 N \sin \theta = P.$$

The unit normal pressure on each side is found by dividing N by the area of contact tc . Substituting for c its value in terms of b and θ , we get:

$$\text{Unit stress} = \frac{P}{bt}.$$

This is on the assumption that there is no friction and that the bearing stress is uniform.

From these considerations we are warranted in assuming that the unit bearing stress on a pin which accurately fits the hole is obtained by regarding the projection of the curved surface on a plane as the surface of contact. This is the common practice of engineers in computing rivets.

PROBLEMS.

1. In Problem 1 of Article 34, what is the unit bearing stress on the pin?

Ans. 10,667 pounds per square inch.

2. In Fig. 41 the diameter of the bolt and of the hole in the lower plate is $\frac{1}{4}$ inch. What must be the thickness and width of this plate in order that the unit shearing stress in bolt shall be one-half of the unit bearing stress and two-thirds of the unit tensile stress in the net section of the plate?

36. Lap Joint with a Single Row of Rivets. — Fig. 47 shows a *lap joint* with a single row of rivets. In any riveted joint the distance a from center to center of adjacent rivets in a row is called the *pitch*. In solving problems, it is often convenient to consider a single strip of width a alone. In this case the problem of a lap joint with a single row of rivets becomes the same as that of Article 34. We may take this strip as extending from center to center of adjacent rivets, as in the lower part of Fig. 47. In this case, the total tension is transmitted in the plate between

the two rivets, and the shear is equally divided between the upper half of the lower rivet and the lower half of the upper rivet. Or we may take the strip as including a single rivet, as in the upper portion of Fig. 47, in which case the shear is transmitted by a single rivet and the tension is divided.

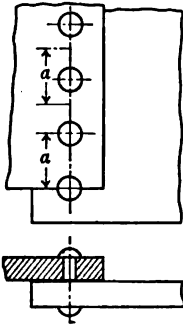

Fig. 47.—Lap Joint with Single Row of Rivets.

In problems in riveting, unless otherwise stated, we shall consider the rivet as exactly filling the rivet hole, and that the holes are drilled or reamed so that there is no injured material around them due to overstrain while punching. In practice, where the holes are punched and not reamed it is customary to make some allowance for this injured material.

In problems where the width of the plate is given, it is generally better to consider the entire plate as a unit. In Problem 1 below, to get the tensile stress we may take a strip 4.25 inches wide transmitting a pull of 15,000 pounds.

PROBLEMS.

1. Two $\frac{1}{2}$ -inch plates, each 8 inches wide, are united by five $\frac{1}{4}$ -inch rivets in a single row to form a lap joint. The joint transmits a pull of 15,000 pounds. Find the unit stress in the *gross* section of the plates, the unit tensile stress in the *net* section between the rivets, the unit shearing stress in the rivets, and the unit bearing stress.

$$\text{Ans. } \left\{ \begin{array}{l} s_t, 7059 \text{ pounds in net section;} \\ s_s, 6790 \text{ pounds;} \\ s_c, 8000 \text{ pounds.} \end{array} \right.$$

2. Two $\frac{1}{2}$ -inch plates are united to form a lap joint by a single row of rivets. The pitch is 3 inches and the diameter of the rivets is $\frac{1}{4}$ inch. Find the unit tensile stress in the net section when the unit shearing stress in the rivets is 7068 pounds per square inch.

3. Two $\frac{1}{2}$ -inch plates are united by a single row of 1-inch rivets to form a lap joint. What must be the pitch if the unit shearing stress in the rivets shall be 6000 pounds per square inch when the unit tensile stress in the net section of the plates is 8000 pounds per square inch, and what is the unit bearing stress?

$$\text{Ans. } 1.94 \text{ inches; } 7540 \text{ pounds per square inch.}$$

37. **Butt Joint.** — Fig. 48 represents a *butt* joint, with double *cover plates*, with a single row of rivets on each side. In a butt joint with double cover plates the rivets are in double shear. In all other respects the problem is the same as that of the lap joint. A butt joint with a single cover plate is the same as a pair of lap joints placed tandem.

PROBLEM.

1. Two $\frac{1}{2}$ -inch plates are united to form a butt joint by means of two $\frac{1}{8}$ -inch cover plates. There is one row of $\frac{1}{2}$ -inch rivets on each side. What must be the pitch if the tensile stress in the net section of the $\frac{1}{2}$ -inch main plates between the rivets shall be 8000 pounds per square inch when the shearing stress in the rivets is 6000 pounds per square inch? What is the bearing stress between rivets and $\frac{1}{2}$ -inch plates? also between rivets and cover plates?

Ans. Pitch, 2.07 inches; s_c , 14,137 and 11,310 pounds per square inch.

Fig. 49 represents a set of tests at the Watertown Arsenal in 1885, to study the behavior of riveted joints. A plate of width b and thickness t was planed down for a portion of its length to some convenient width and united to a pair of cover plates, thus forming one-half of a butt joint. Wrought-iron rivets were used of nominal diameter one-sixteenth of an inch less than the diameter of the holes. In calculating it was assumed that the finished rivets entirely filled the rivet holes.

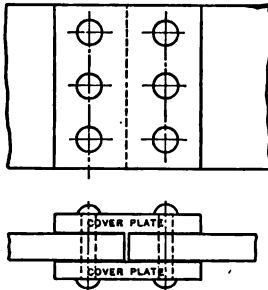

Fig. 48. — Butt Joint with Single Row of Rivets on Each Side.

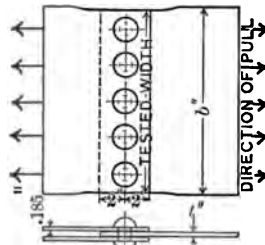

Fig. 49. — Half of Butt Joint.

PROBLEMS.

2. In test piece No. 1353 (Watertown Arsenal, 1885, page 867), the breadth b was 14.90 inches; the tested width, 14.39 inches; the actual thickness of the plate, 0.248 inch. There were five rivets in inch drilled holes. The joint failed by tension along the line of the rivet holes under a pull of 156,440 pounds. The calculated results as published are:

AREAS.	Square inches.
Gross sectional area of plate.....	3.569
Net sectional area of plate.....	2.329
Bearing surface of rivets.....	1.240
Shearing area of rivets.....	7.854

MAXIMUM STRESS ON JOINT.	Pounds per sq. in.
Tension in gross section of plate.....	43,830
Tension on net section of plate.....	67,170
Compression on bearing surface of rivets.....	126,160
Shearing on rivets.....	19,920

Verify these results.

3. In test piece No. 1355 the results were:

Tested width of plate.....	15 inches.
Actual thickness.....	0.251 inch.
Ultimate load.....	167,200 pounds.

There were five rivets in 1-inch holes. "Fractured two outside sections of plate at edge along line of riveting; the two middle sections sheared in front of the rivets."

Compute all unit stresses as in Problem 2.

Fig. 50 is a copy of a photograph of this plate after failure. It shows failure by tension across the net section and shear in front of the rivets. It also shows elongation of the rivet holes due to bearing pressure on the plate, combined with shear.

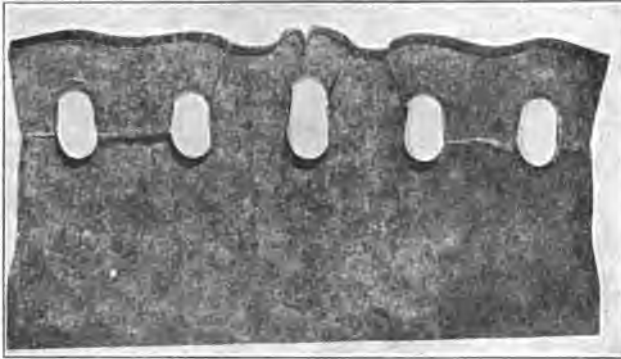

Fig. 50. — Failure of Riveted Plate.

In order to compare the strength of the material in the net section of a riveted joint with the ordinary tension tests, two strips were sheared from each sheet of steel, one lengthwise, the other crosswise the sheet. These were planed to a width of 1.5 inches and tested in the usual way.

From the sheet used in No. 1353 two test pieces were taken. These gave as ultimate tensile strengths:

	Pounds per sq. in.
No. 1213, lengthwise.....	59,180
1224, crosswise.....	60,840

Four test strips were taken from the sheet used for No. 1355:

	Pounds per sq. in.
No. 1214, lengthwise.....	53,680
1220, ".....	62,300
1225, crosswise.....	61,230
1226, ".....	60,890

Comparing these results with the unit stresses in the net section of the riveted plates, we find that the stress in the test pieces is considerably lower. This is an illustration of Article 24. The net section in the riveted plate is relatively short and consequently is kept from necking as it would in a longer piece. Notice that there is no certain difference between the pieces lengthwise and those crosswise the plate. This is explained by the fact that in rolling the metal it was worked both ways, so that there was no definite grain in one direction.

In Problems 2 and 3, the design was such that there was relatively small shearing stress. The rivets used were large compared with the thickness of the plate. Problem 4, below, represents a different case with a different mode of failure.

PROBLEMS.

4. In a test piece similar to Fig. 49 (Watertown Arsenal, 1886, page 1401), the following data are given; tested width, 13.11 inches; thickness, 0.630 inch; five rivets in 1-inch drilled holes; failed by shearing the rivets under a pull of 295,500 pounds; rivet holes elongated 0.31 inch, 0.32 inch, 0.26 inch, 0.25 inch, 0.24 inch.

Calculate the unit stresses.

	Pounds per sq. in.
<i>Ans.</i> Tensile stress in net section.....	57,840
Bearing stress.....	93,810
Shearing stress on rivets.....	37,620

5. In Problem 4, the cover plates were 0.384 inch thick. Find the unit tensile stress in the net section.

Fig. 51 is a copy of a photograph of a rivet which failed by shear as in Problem 4 (Watertown Arsenal, "Tests of Metals," 1886, page 1567).

38. Rivets in More than One Row. — Rivets are frequently arranged in more than one row. The rivets in the second row may be placed directly behind those in the first row, or they may be arranged zigzag as shown in Fig. 52. The figure shows the plates and *rivet holes* for a lap joint with a double row of rivets. In this zigzag arrangement the second row must be set back sufficiently far that the sum of the net diagonal intervals c and e shall considerably exceed the net interval f between rivet holes in the same row. If the rows are placed too close together the joint is likely to fail along the zigzag line.

In computing problems with two or more rows of rivets, we assume that the *shearing stress* is the same in the rivets of all

rows. If we consider a strip of width a equal to the pitch, extending from the center of rivet hole 1 to the center of rivet hole



Fig. 51. — Failure of Rivet.

2, the total stress transmitted by this strip is carried by the lower half of rivet 1, the upper half of rivet 2, and the whole of rivet 3. Or we may take a strip of width a , which entirely includes one rivet in each row. In any case the entire stress transmitted by a strip of gross width a passes through between the rivets of the first row. Half of this stress is carried as shear to the lower plate by the rivet of the first row and the other half passes as tension through the second row.

Fig. 53 shows an arrangement of three rows, with twice as many rivets in the second row as in either of the others. In solving a problem of this kind, we take as the unit a strip of width equal

to the pitch in the outer rows. This strip may extend from the middle of rivet 1 to the middle of rivet 5, or it may include the whole of rivet 1 and none of rivet 5. In either case the strip embraces two rivets in the middle row and one in each of the others.

PROBLEMS.

1. In a joint similar to Fig. 52, the plates are $\frac{1}{4}$ inch thick and are united by two rows of $\frac{1}{2}$ -inch rivets to form a lap joint. The pitch is $2\frac{1}{2}$ inches. If the unit tensile stress in the gross section is 4800 pounds per square inch, find the unit tensile stress in the net section at the left row in the upper plate, the unit tensile stress at the right row in the upper plate, the unit shearing stress in the rivets, and the unit bearing stress.

	Pounds per sq. in.
<i>Ans.</i> Tensile stress, left upper and right lower	7200
Tensile stress, right upper and left lower	3600
Shearing stress in rivets	6548
Bearing stress	7200

2. In a lap joint similar to Fig. 53, the pitch in the outer rows is 5 inches, and in the middle row 2.5 inches. The plates are $\frac{1}{4}$ inch thick and are joined

by $\frac{1}{4}$ -inch rivets. When the unit tensile stress in the gross section is 4000 pounds per square inch, find the unit shearing stress in the rivets and the unit tensile stress in the net section at the right row in the upper plate and the left row in the lower plate.

Ans. $\left\{ \begin{array}{l} s_s, 5659 \text{ pounds per square inch;} \\ s_t, 4706 \text{ pounds per square inch.} \end{array} \right.$

3. In Problem 2 find the unit tensile stress in the net section at the middle row in each plate.

Ans. 4286 pounds per square inch.

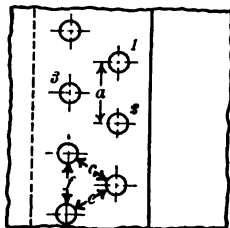

Fig. 52. — Lap Joint with Double Row of Rivets.

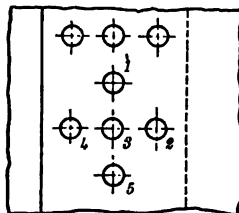

Fig. 53. — Rivets in Three Rows.

4. In Problem 2 show that the unit tensile stress in the net section at the left row in the upper plate is one-fourth that in the right row in the same plate.

5. A butt joint is formed of two $\frac{1}{2}$ -inch plates united by two $\frac{3}{8}$ -inch cover plates. There are two rows of $\frac{1}{2}$ -inch rivets on each side, the inner rows of 3-inch pitch and the outer rows of 6-inch pitch. The unit stress in the gross section of the $\frac{1}{2}$ -inch plates is 6000 pounds per square inch. Find the unit tensile stress in the net section at each row of rivets in the $\frac{1}{2}$ -inch plates and at one of the inner rows in the cover plates. Find the unit shearing stress in the rivets and the unit bearing stress between the rivets and the $\frac{1}{2}$ -inch plates.

		Pounds per sq. in.	
Ans.	{	s_t in $\frac{1}{2}$ -inch plates in outer rows	7,024
		s_t in $\frac{1}{2}$ -inch plates in inner rows	5,647
		s_t in cover plates at inner rows	7,529
		s_s in all rivets	4,989
		s_c between rivets and main plates	13,714

6. In Problem 5 what should be the thickness of the cover plates if the unit tensile stress does not exceed the maximum in the main plates?

7. Taking ultimate strengths from Problems 2 and 4 of Article 37, what is the factor of safety in Problem 5 for each case?

8. Fig. 54 shows a joint tested at the Watertown Arsenal (1896, pages 258, 259). The average thickness of the plates was 0.534 inch; the rivet holes, $\frac{1}{2}$ inch. The joint failed by tension along line shown when the total pull was 502,200 pounds. Find the unit tensile stress at each row of rivets and the unit shearing and bearing stress.

39. **Efficiency of a Riveted Joint.** — The ratio of the strength of a riveted joint to the strength of one of the plates which it unites is called the *efficiency* of the joint. The efficiency may

also be defined as the ratio of the unit stress in the gross section, when the joint is stressed to its allowed limit, to the allowable unit stress in the plates. If the joint is so designed as to make it at least as strong in shear and compression as it is in tension at the net section, the efficiency becomes the ratio of the net to the gross sections. For instance, if two plates are united by $\frac{3}{4}$ -inch rivets with a pitch of 3 inches, the efficiency is 75 per cent, provided the thickness of the plates is such that the joint is no stronger in tension than it is in shear and compression.

PROBLEMS.

In the following problems, unless otherwise stated, we shall use as allowable unit stresses: s_t , 9000; s_s , 6000; and s_c , 12,000 pounds per square inch.

1. Two $\frac{3}{4}$ -inch plates are united by a single row of 1-inch rivets to form a butt joint. What is the efficiency if the pitch is $2\frac{1}{2}$ inches based on tensile stress only? What pull will produce the maximum allowable tensile stress? What are the shearing and bearing stresses at this pull?

Ans. $57\frac{1}{2}$ per cent efficiency.

2. Two $\frac{3}{4}$ -inch plates are united to form a lap joint by two rows of $\frac{3}{4}$ -inch rivets spaced 3 inches apart. What stress determines the strength of the joint? What is its efficiency?

Ans. Weakest in shear. Efficiency, 39.3 per cent.

3. In Problem 2 what should be the pitch in order to make the joint equally strong in shear and in tension? What is the efficiency?

Ans. 1.93 inches; 61.1 per cent.

4. In Problem 3 is the unit bearing stress within the allowed value?

It is possible to design a riveted joint so as to bring tensile, compressive, and shearing stresses to their allowable values at the same load. This is not usually done, however, as it would involve inconvenient sizes of rivets, and frequently require rivet holes too small relatively to the size of the plate to be punched. Usually the joint is designed for shear and tension in the net section and then examined to see if the bearing stress is within the allowable limit.

PROBLEMS.

5. If the allowable bearing stress is twice the shearing stress, what is the minimum thickness of plate which can be used with $\frac{3}{4}$ -inch rivets in a lap joint with a single row of rivets? *Ans.* 0.295 inch.

6. Derive an expression for thickness of plate in terms of diameter of rivet which will make the bearing stress twice the shearing stress.

$$\text{Ans. } \begin{cases} t = \frac{\pi d}{8} & \text{for single shear;} \\ t = \frac{\pi d}{4} & \text{for double shear.} \end{cases}$$

7. Solve Problem 6 if the allowable shearing stress is two-fifths of the bearing stress.

8. Using shearing stress two-fifths the bearing stress and two-thirds the tensile stress, and using rivets to the nearest sixteenth, design a butt joint with

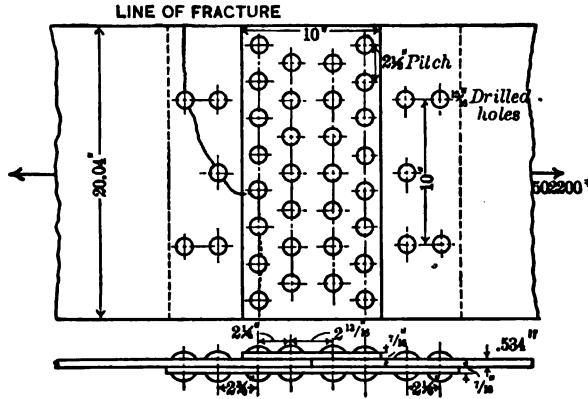

Fig. 54. — Butt Joint Tested at Watertown Arsenal.

double cover plates with one row of rivets equally spaced on each side to unite two $\frac{3}{8}$ -inch plates. Find the efficiency of the joint.

Ans. 1-inch rivets; pitch, 2.67 inches; efficiency, 62.5 per cent.

9. In Problem 8 use three rows of rivets having a pitch ratio 1 : 2 : 4 on each side. *Ans.* Efficiency, 92 per cent; cover plates at least $\frac{1}{8}$ inch thick.

Lewis P. McGilvary
Elect. Eng. 1916

CHAPTER V.

BEAMS.

40. Definition of a Beam. — Fig. 55 is a front elevation of a beam supported near the ends and carrying a single *concentrated* load P in addition to its own weight. If the beam is uniform, its own weight is a *uniformly distributed* load. There is an upward reaction at each support. A beam may be defined as a rigid body subject to transverse loads and reactions.

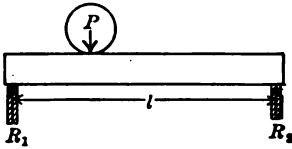

Fig. 55. — Beam Supported at Ends.

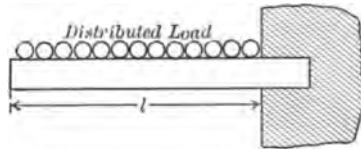

Fig. 56. — Cantilever.

41. Kinds of Beams. — Beams may be classified according to the character of the support and the method of loading. Fig. 56 represents a beam fixed at one end and free at the other. This kind of beam is called a *cantilever*. Fig. 57 is a beam

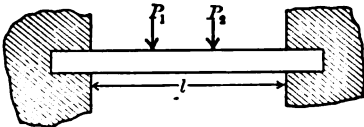

Fig. 57. — Beam Fixed at Both Ends.

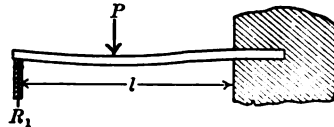

Fig. 58. — Beam Fixed at One End and Supported at the Other.

fixed at both ends. Fig. 58 is *fixed* at the right end and *supported* at the left. Fig. 59 is a beam which *overhangs* its supports. A beam with three or more supports, as in Fig. 60, is a *continuous* beam.

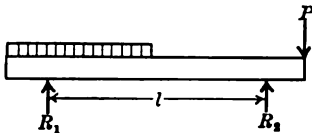

Fig. 59. — Beam Overhanging its Supports.

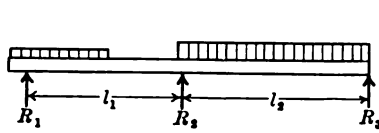

Fig. 60. — Continuous Beam.

The figures show different methods of loading and some of the ways of representing the loads and reactions in diagrams and drawings.

In Figs. 55 and 58, we have a single concentrated load. In Fig. 57, there are two concentrated loads. In Fig. 56, there is a uniformly distributed load over the entire length. In Fig. 59, there is a uniformly distributed load over half of the length, and a concentrated load at the right end. In Fig. 60, there is a distributed load over part of the left portion and another load of greater weight per unit length over the right half.

A beam is not necessarily horizontal. A vertical fence post subjected to the horizontal force of the wind or the weight of a gate is a cantilever beam. A post at the end of a line of wire fence is a vertical beam supported at one end and partially fixed at the other, with several concentrated loads due to the tension in the wire.

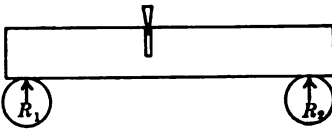

Fig. 61.

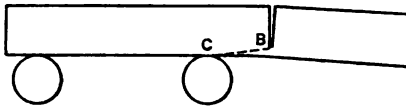

Fig. 62.

42. Internal Stresses in Beams. — If a log of wood, supported near the ends, is cut in two by a saw running horizontal, the saw cut gradually narrows at the top. In a large log it becomes necessary to drive a wedge into the cut above the saw, as shown in Fig. 61 to prevent it from "pinching." The material which has been removed by the saw was under compressive stress. If the log overhangs the support as in Fig. 62, the cut widens and finally splits off along the line BC . The material cut in this case was in tension and the final failure is due to shear. If the log overhangs each support one-fourth of its length and the cut is at the middle, there is no tendency to open or close. There is zero stress at this point under these conditions.

We learned in Mechanics, that when a body is subjected to a set of coplanar nonconcurrent forces, these forces may be replaced by a single force at any desired point in the plane and a single couple. We learned also that when a body in equilibrium is cut into two portions at any section, the resultant of the external

forces upon either portion is equal to the forces across this section from this portion to the other.

Fig. 63 represents a cantilever of uniform section, weighing w pounds per foot. Let us consider the forces at a section EF at a distance x from the left end. If we consider the portion to the left of the section EF as a free body in equilibrium, we find that the only external force is the weight of the portion vertically downward applied at its center of gravity, a distance $\frac{x}{2}$ from the section. This weight is wx pounds. To produce equilibrium, there must be an equal force wx vertically upward acting from the right portion to the left across the section EF . There is an equal force acting vertically downward from the left portion

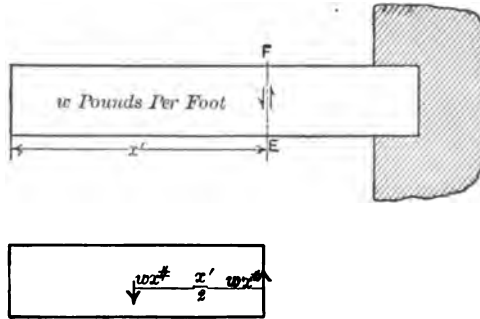

Fig. 63. — Shear at Beam Section.

to the right. This last force is the single force above mentioned, which replaces the external forces acting on the left portion. It is called the *vertical shear* at the section. The *vertical shear* at any section of a beam is the sum of the vertical components of all the external forces to the *left* of the section. It is regarded as positive upward and negative downward. It is, of course, equal and opposite to the sum of the vertical components of all the external forces acting upon the portion to the right of the section. Either portion may be used in determining the *magnitude* of the vertical shear. The left portion alone determines the sign. These are merely arbitrary conventions, but they are commonly used in the discussion of Strength of Materials. In this book, total vertical shear is represented in algebraic formulas by the letter S (many authors use V). The author finds it

convenient to represent shear by an arrow with a single barb. The one on the left of EF , in Fig. 63, indicates that the shear from the left portion to the right is downward. The arrow on the right of the section indicates that there is a shearing stress upward from the right to the left portion.

PROBLEMS.

1. A cantilever beam weighing 40 pounds per foot is fixed at the right end and carries a load of 100 pounds 2 feet from the left end. Find the vertical shear at 1 foot and at 3 feet from the left end.

Ans. At 1 foot, $S = -40$ pounds;

At 3 feet, $S = -220$ pounds.

2. A cantilever beam weighing 30 pounds per foot is fixed at the left end and carries a load of 120 pounds 3 feet from the right end. Find the total shear 2 feet and 4 feet from the right end.

Ans. 60 pounds and 240 pounds.

3. A beam 8 feet long weighing 30 pounds per foot is supported at the left end and 2 feet from the right end. Find the total shear 2 feet and 4 feet from the left end.

Ans. 20 pounds, -40 pounds.

When the external forces are not all given, it is necessary to determine them for at least one side of the section. In this case it is sufficient if one reaction is determined. It is better to determine both reactions by moments and then check by vertical resolutions. Taking moments about the right support, we get 80 pounds as the reaction at the left support. Taking moments about the left support, we find the right reaction to be 160 pounds. In taking moments about the right support, consider the entire beam at its center of gravity 2 feet from this support; and do not divide it into two portions of 6 feet and 2 feet.

4. A beam 10 feet long weighing 40 pounds per foot is supported at the ends and carries a load of 120 pounds 3 feet from the left end. Find the reactions at the supports and the vertical shear 2 feet and 4 feet from the left end. Check the magnitude of the shear by using the right portion as a free body.

Ans. $R_1, 284; R_2, 236; S, 204$ and 4 pounds.

43. External Moment and Resisting Moment. — In Fig. 63 the external force of gravity at the center of the left portion is resisted by the vertical shear upward at the section EF . This vertical shear from the right portion to the left is called the resisting shear. This resisting shear and the weight of the portion together form a couple of which the forces are each wx and the moment arm $\frac{x}{2}$. The moment is $\frac{wx^2}{2}$. This is the *external moment*. We may get this moment in another way. Compute the moment of all the external forces acting on the portion about a horizontal axis perpendicular to the beam through some point

in the section EF . The moment of the resisting shear is zero, since its moment arm is zero; the moment of the weight is $w x$ multiplied by $\frac{x}{2}$. The external moment at any section is the moment with respect to a horizontal axis in the section of all the forces acting on the portion of the body to the left of the section. The external moment is balanced by a second couple, the forces of which act across the section from the other portion. This is the *resisting moment*. In Fig. 63 the forces of the resisting moment are tensile at the top and compressive at the bottom.

In Fig. 63 we have the weight $w x$ applied at the center of gravity of the left portion, replaced by an equal force applied at EF (the external shear), and a couple which we call the external moment. The effect of this external moment is to tend to turn the left portion counterclockwise. It is *convenient* to give this moment the negative sign. When the moment of the *external forces* tends to turn the *left portion clockwise*, the moment is *positive*. This is an arbitrary convention, which is convenient in calculating deflections.

If the student prefers to think of *counterclockwise* rotation as positive, he may fix his attention on the resisting moment. When the resisting moment acting on the *left* portion of a beam across any section is counterclockwise, the moment at that section is positive.

PROBLEMS.

1. A cantilever beam weighing 30 pounds per foot is fixed at the right end and carries a concentrated load of 80 pounds at the left end. Find the external moment and shear 3 feet from the left end.

Ans. Moment, -375 foot pounds; shear, -170 pounds.

2. A cantilever beam weighing 20 pounds per foot is fixed at the left end and carries a concentrated load of 100 pounds at the right end. Find the external moment and shear 4 feet from the right end. (Use portion to the right of section as free body.)

Ans. Moment, -560 foot pounds; shear, 180 pounds.

3. A beam 12 feet long weighing 20 pounds per foot is supported at the ends. Find the external moment and shear 2 feet from the left end, 2 feet from the right end, and at the middle.

<i>Ans.</i>	From left end.	Foot-pounds moment.	Pounds shear.
	2 feet	200	80
	6 feet	360	0
	10 feet	200	-80

4. A beam 20 feet long weighing 6 pounds per foot is supported at the ends and carries a load of 80 pounds 6 feet from the left end. Find the moment

and shear at 5 feet from the left end, at the middle, and at 5 feet from the right end. Check results, using the portion to the right of the section.

Ans.	From left end.	Foot-pounds moment.	Pounds shear.
	5 feet	505	86
	10 feet	540	-24
	15 feet	345	-54

5. A beam of length l supported at the ends carries a load P at the middle. Find the moment at the middle.

Ans. Moment at the middle, $\frac{Pl}{4}$.

6. A beam of length l supported at the ends carries a uniformly distributed load of w pounds per unit length. Find the moment at the middle, and the shear at the middle.

Ans. $\frac{wl^2}{8}$, 0.

7. A beam supported at the ends carries a uniformly distributed load W . Find the moment at the middle.

Ans. $\frac{Wl}{8}$.

8. Find the moment at the fixed end of a cantilever of length l due to a load P at the free end, also that due to a uniform load W .

Ans. $-Pl$, $-\frac{Wl}{2}$.

44. Experiments Illustrating Moment and Shear. — In Fig. 64 we have a front elevation of a cantilever beam which has been

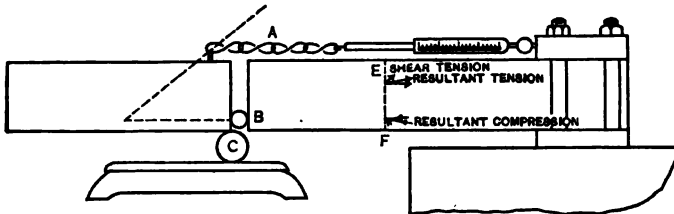

Fig. 64. — Shear and Moment at Beam Section.

cut in two along a vertical plane. A chain A is attached at the top connecting the two portions and a cylinder B is placed between them near the bottom. The chain exerts a pull in the direction of its length and the cylinder exerts a horizontal push. When the chain is horizontal the left portion of the beam is not in equilibrium, as there is no resisting shear to oppose the external shear. A second cylinder C may take the place of this resisting shear. If this cylinder C rests on a scale platform, we may determine the resisting shear by weighing. If the chain is horizontal and the friction of the cylinder B is small, we find the resisting shear equal to the weight of the portion of the beam to the left of the section.

If a spring balance is attached to the chain A , we may measure the tension and compute the resisting moment. We find that the moment of the tension in the chain about the axis of the cylinder B is equal to the moment of the weight of the left portion about the axis of the cylinder C . That is, the resisting moment and the external moment are equal. If we move the chain in a vertical plane about its left end, the load on the cylinder C gradually decreases. In the position shown by the dotted line the weight becomes zero. The entire vertical shear is now carried by the vertical component of the pull on the chain. This is the position in which the line of pull of the chain intersects the horizontal line through B directly below the center of gravity of the left portion of the beam. This is the condition of equilibrium of three forces. In an actual beam there is tension in the upper fibers. This tension has a component upward. The compression in the lower fibers has also a component upward. We learned in Article 31 that a shearing stress is equivalent to a tensile and a compressive stress at right angles to each other and 45 degrees with the plane of shear. The real stress in the upper fibers of any section of Fig. 64 is the resultant of the horizontal tension and an inclined tension due to shear. In the same way the compression below the middle may be regarded as made up of a horizontal compression and an inclined compression due to shear. This is shown diagrammatically at the section EF , Fig. 64.

Fig. 65 represents a beam supported near the ends. The external moment is positive; hence the resisting moment is

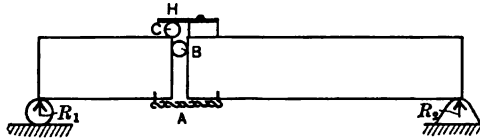

Fig. 65.

counterclockwise. The horizontal force which acts across any section from the right portion to the left must push at the top and pull at the bottom; consequently we put the chain at the bottom and the cylinder near the top.

The shear at a section near the left end is positive. The vertical forces *tend* to move the left portion upward relatively to the

right portion. To resist this shear without changing the end reaction, we place the cylinder C on the top of the left portion and support the right portion by means of a small extension H resting on C .

Fig. 66 represents another beam supported at the ends. Instead of a single chain under the middle of the section, we have a

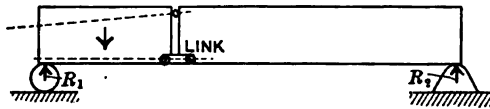

Fig. 66.

pair of links pulling against pins in the front and back vertical surfaces. Instead of the cylinder B , we have a prism of square section, with edges in contact with the portions of the beam. If we place this prism with its diagonal somewhat inclined to the horizontal, we find one position of unstable equilibrium where it will support both shear and compression.

PROBLEMS.

1. In a beam similar to Fig. 64, the portion to the left of the section is 3 feet long and weighs 16 pounds. The distance from the center of the cylinder B to the chain A is 8 inches. What is the tension in the chain in pounds if the cylinder C is exactly under the end? *Ans.* 36 pounds.
2. In Problem 1, if the chain A is attached to the upper corner of the left portion, at what angle should it be placed in order that there may be no load on cylinder C ? *Ans.* The angle with the horizontal whose tangent is $\frac{1}{2}$.
3. In Problem 1, if the chain is attached to a point in the upper surface at a distance of 4 inches to the left of the right end of the portion, at what angle should it be placed to the horizontal in order that there may be no load on C ?
4. In Problem 1, replace cylinder B by a small square block with faces parallel to the section, and remove cylinder C . What must be the coefficient of friction between the block and the portions of the beam in order that the friction will support the shear? *Ans.* 0.44.
5. In Problem 4, if the coefficient of friction is 0.4, what is the maximum distance between the block and chain if the friction supports the shear?
6. A beam 6 feet long weighing 72 pounds is supported at the ends. The beam is cut in two at the middle and supported by a pair of links and a square prism as shown in Fig. 66. If the vertical distance between the plane of the links and the axis of the prism is 8 inches, find the total tension on the links. *Ans.* 81 pounds.
7. The beam in Problem 6 is cut 2 feet from the left end. The tension links are horizontal. What is the angle of inclination of the diagonal of the

compression prism? (Solve by resolutions and moments, using the left portion as a free body. Also solve by finding the resultant of the left reaction and the weight of the 2 feet of beam, and the condition that the lines of the remaining two forces intersect on this resultant.)

8. A uniform beam 10 feet long and 1 foot deep rests on supports each 2 feet from the ends. The beam is cut in two at the middle and drops slightly till the edges touch at the top. What must be the coefficient of friction at the supports to hold it in this position?

45. **Shear Diagrams.** — It is convenient to represent the total shear at all sections of a beam by means of curves called *shear diagrams*. Fig. 67 is the shear diagram for Problem 3 of Article

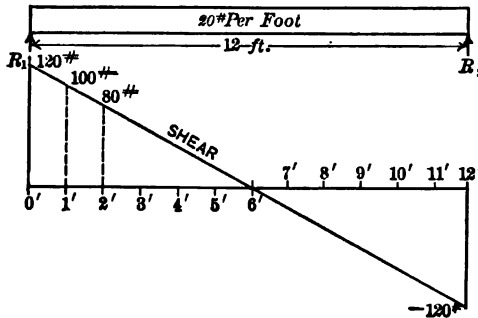

Fig. 67. — Shear Diagram for Distributed Load.

43. The end reactions are each 120 pounds. We begin at the left support and take a section infinitely near the end. The vertical reaction, R_1 , is 120 pounds and the weight of the portion is negligible. The vertical shear is 120 pounds. Accordingly, we lay off an ordinate 120 units long, using some convenient scale. We may now take points at 1-foot intervals on the beam and compute the shear. At 1 foot from the end it is 100 pounds; at 2 feet it is 80 pounds, etc. We notice that the curve which joins these points is a straight line, since the ordinates have a constant rate of change. All that is really necessary is to compute the shear at the ends and connect the points by a straight line. This straight line, together with the ordinates at the ends, makes the shear diagram.

Fig. 68 is the shear diagram for a beam 10 feet long, supported at the ends, with a uniform load due to its own weight of 60 pounds per foot and a concentrated load of 200 pounds, 3 feet from the left end. By moments about the right support, we

find the left reaction, R_1 , to be 440 pounds. By moments about the left support, we find R_2 to be 360 pounds. The sum of these reactions is equal to the total load, affording a check.

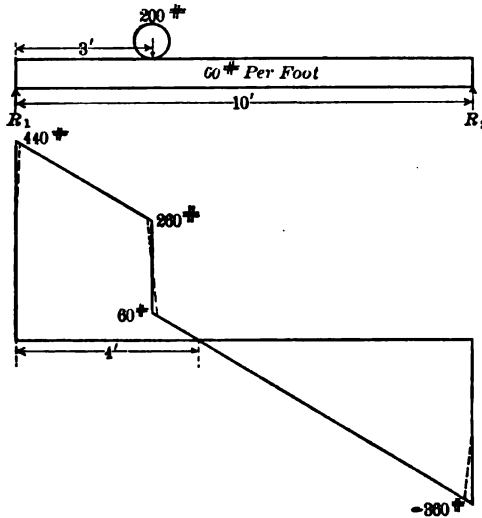

Fig. 68. — Concentrated and Distributed Loads.

Infinitely close to the left support the shear is 440 pounds. It drops 180 pounds in the first 3 feet and is 260 pounds infinitely close to the load of 200 pounds. In a negligible distance in passing from the left side to the right side of the concentrated load it drops an additional 200 pounds, so that it becomes 60 pounds infinitely close to the load on the right side. Here the shear diagram is a vertical line. Beyond the concentrated load the shear drops at the rate of 60 pounds per foot for the remaining 7 feet, which brings it to -360 pounds infinitely close to the right support. The reaction of 360 pounds raises it to the initial line. The shear diagram crosses the zero or initial line 1 foot to the right of the concentrated load, or 4 feet from the left support.

Notice that the shear diagram in Fig. 68 drops vertically downward under the load of 200 pounds, and we speak of points as infinitely near the load on either side. This would mean that the load is applied along a mathematical line running across the beam. The actual surface of contact is a band of some width running across the beam, and the actual shear diagram is something like that represented by the dotted lines.

PROBLEMS.

1. A uniform beam 15 feet long weighing 40 pounds per foot is supported at the ends and carries a concentrated load of 360 pounds 3 feet from the left end. Construct the shear diagram, using as abscissas 1 inch equals 2 feet of length, and as ordinates 1 inch equals a shear of 100 pounds. Find the equation of the shear diagram on each side of the load.

$$\text{Ans. } S = 588 - 40x; S = 228 - 40x.$$

2. In Problem 2 find the position of zero shear from the equations.
3. A cantilever beam of uniform section, weighing 20 pounds per foot, is fixed at the right end and projects 10 feet to the left. It carries a concentrated load of 80 pounds 3 feet from the free end. Construct the shear diagram, using the scale of Problem 1. Find the equation of the two parts of the line, taking the origin at the left end.
4. A beam 24 feet long, supported at the ends, carries a load of 4000 pounds 8 feet from the left end and a load of 5000 pounds 5 feet from the right end. Construct the shear diagram to the scale 1 inch equals 4 feet of length and 1000 pounds shear. Neglect the weight of the beam.

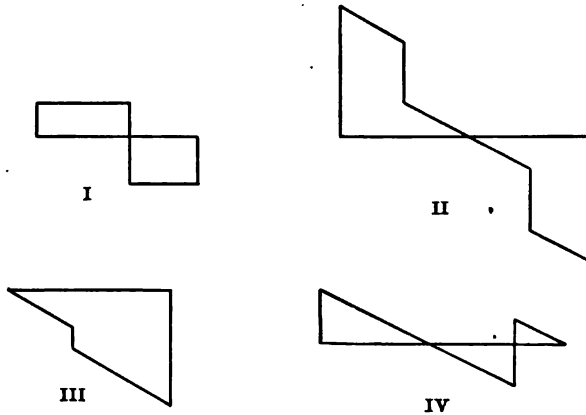

Fig. 69. — Shear Diagrams.

Shear diagrams are usually made up of straight lines. These lines are horizontal from one load to the other when the loads are concentrated and the weight of the beam is neglected. With uniformly distributed loads, the lines slope downward from left to right. (With distributed loads pushing up, as in the bottom of a boat due to the water pressure, the lines slope upward.) Where loads are distributed not uniformly, as in the case of the water pressure on a vertical dam, the shear diagram is curved.

The student should become sufficiently familiar with the simpler shear diagrams to be able to recognize the character of the loading at a glance.

PROBLEM.

→ 5. Describe the loading and the character of support which gives each of the shear diagrams of Fig. 69.

46. **Moment Diagrams.** — Moment diagrams are constructed in the same way as shear diagrams, using external moment as ordinates. In this book we shall draw positive moment upward, though many engineers prefer the opposite.

Shear diagrams are easily constructed, as they usually consist of straight lines. Moment diagrams are curved, except when the loading is made of concentrated loads only.

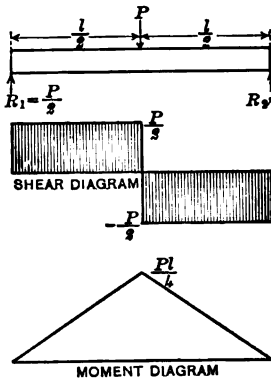

Fig. 70. — Single Concentrated Load.

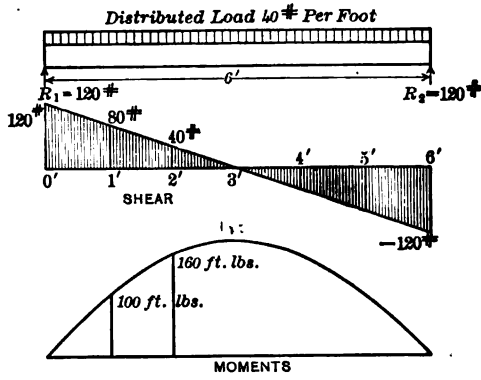

Fig. 71. — Uniformly Distributed Load.

Fig. 70 shows the shear and moment diagram for a beam supported at the ends and carrying a load P at the middle. The weight of the beam is neglected. The end reactions are $\frac{P}{2}$. The moment at any section at a distance x from the left end is $\frac{Px}{2}$, provided x is not greater than one-half of the length. Under the load the moment is $\frac{Pl}{4}$. The moment diagram for the left half of the beam is a straight line through the points $(0, 0)$ and $(\frac{l}{2}, \frac{Pl}{4})$. Beyond the load, the moment is due to the reaction at the left support turning clockwise minus that due to the load at the

middle. At a distance x from the left end when x is greater than

$\frac{l}{2}$,

$$\text{Moment} = \frac{Px}{2} - P\left(x - \frac{l}{2}\right) = \frac{Pl}{2} - \frac{Px}{2} = \frac{P}{2}(l - x).$$

This is also a straight line. Notice that the last of the three expressions for moment is the one which we get directly, if we use the portion to the right of the section as a free body. The right reaction is $\frac{P}{2}$ and the moment arm is $l - x$. The sign is opposite, as it should be.

Fig. 71 gives the shear and moment diagrams for a beam supported at the ends, with a uniformly distributed load. The moment diagram is a parabola with the vertex at the top.

PROBLEMS.

1. With the data of Fig. 71, find the equation of the moment curve.
2. Find the equation of the moment curve of a beam supported at the ends, with a uniformly distributed load of w pounds per unit length.

$$\text{Ans. } M = \frac{wlx}{2} - \frac{wx^2}{2} = \frac{wx}{2}(l - x).$$

3. A beam 10 feet long is supported at the ends and carries a concentrated load of 200 pounds 6 feet from the left end. Neglecting the weight of the beam, construct the shear and moment diagrams to the scale 1 inch horizontally equals 2 feet of length, 1 inch vertically equals 50 pounds shear and 100 foot pounds of moment. Derive the equation of each curve.

Ans. On the right of the load, $S = -120$ pounds; $M = 1200 - 120x$.

4. A beam of uniform section, 10 feet long, is supported at the ends. It carries a uniform load, including its own weight, of 16 pounds per foot. Calculate the moment for each foot and construct the shear and moment diagrams, using the same scale as in Problem 3.

5. A beam 10 feet long, supported at the ends, carries a distributed load equal to that of Problem 4, and a concentrated load equal to that of Problem 3. Using the same scale as in those problems, construct the shear and moment diagrams for the combined loadings.

It is best to construct the moment diagrams for the concentrated and distributed loads separately. Then combine the two by adding the ordinates graphically. Fig. 72 shows the shear and moment diagrams for another beam supported at the ends, with a uniform load and *two* concentrated loads. The moment diagram for the concentrated loads consists of three straight lines. To construct the moment diagram for the distributed loads, it is sufficient to compute the moments for foot intervals for one side of the middle. The resultant moment AD at the 2-foot position is the sum of the ordinates AB and AC . With a scale or compass lay off from B the distance BD equal to AC . This may be done for every half-foot interval or less.

6. From your curve of Problem 5 find the slope of the moment diagram at 5 feet and at 6 feet. Find also the position of maximum moment and the corresponding value of the shear.

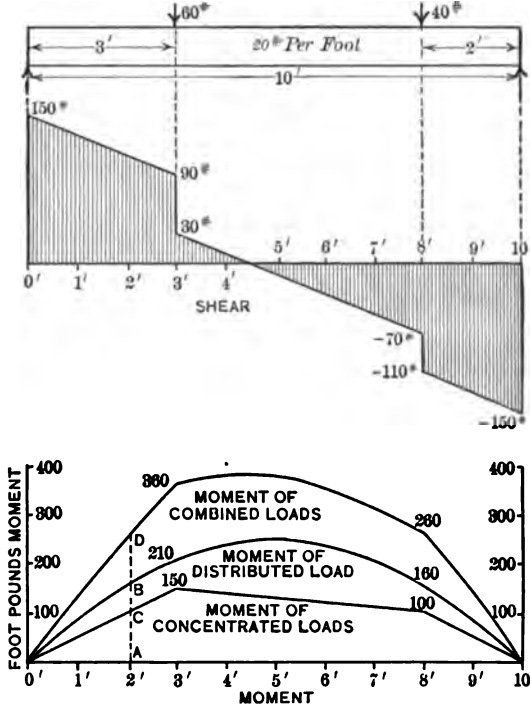

Fig. 72. — Concentrated and Distributed Loads.

47. **Relation of Moment and Shear.** — Fig. 73 represents a beam supported at the ends and carrying a concentrated load P at a distance a from the left end and distributed load of w per unit length. The reaction at the left support is R_1 . Calculating the moment at a section at a distance x from the left end (where x is greater than a), we get:

$$M = R_1x - P(x - a) - \frac{wx^2}{2}. \tag{1}$$

Differentiating with respect to x , we get the derivative:

$$\frac{dM}{dx} = R_1 - P - wx. \tag{2}$$

We recognize the second member of equation (2) as expressing literally the definition of total vertical shear. Hence

$$\frac{dM}{dx} = S. \quad \text{Formula V.}$$

The derivative of the moment at any section gives the shear at the section, except at a concentrated load or reaction where the shear diagram is vertical.

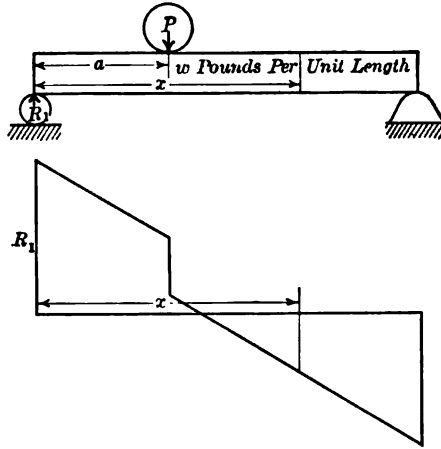

Fig. 73. — Shear Diagram.

The above proof of Formula V is not general. We will now consider Fig. 74 for a proof for a more general case. This figure represents a beam of indefinite extent. The origin of coördinates is taken in the vertical line O . The beam carries loads P_1 , P_2 , etc., at positions a_1 , a_2 , and a distributed load of w per

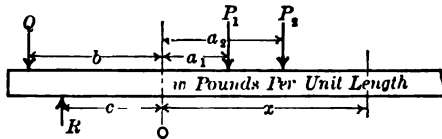

Fig. 74.

unit length. There are also loads and reactions to the left of the origin. The resultant of all the loads to the left of the origin, whether distributed or concentrated, may be replaced by a single load Q at some distance b to the left of the origin. The resultant of all the reactions on the left of the origin is a single force R acting upward at some point at a distance c to the left of the

origin. Computing the moment with respect to a section at a distance x to the right of the origin:

$$M = R(c + x) - Q(b + x) - P_1(x - a_1) - P_2(x - a_2) - \frac{wx^2}{2}. \quad (3)$$

Differentiating:

$$\frac{dM}{dx} = R - Q - P_1 - P_2 - wx. \quad (4)$$

The second member of (4) is the shear at the section, hence

$$\frac{dM}{dx} = S. \quad \text{Formula V.}$$

Where there are several concentrated loads, such as P_1 , the moment equation for points to the right of the origin for all points to the right of these loads may be written:

$$M = R(c + x) - Q(b + x) - \sum P(x - a) - \frac{wx^2}{2}; \quad (5)$$

and the shear equation:

$$S = R - Q - \sum P - wx. \quad (6)$$

There might be an infinite number of loads P , so that the equations apply to any distribution whatever. Some of the concentrated loads may be negative.

Considering Fig. 73,

On the left of the load,

$$M = R_1x - \frac{wx^2}{2},$$

$$\frac{dM}{dx} = R_1 - wx,$$

On the right of the load,

$$M = R_1x - \frac{wx^2}{2} - P(x - a),$$

$$\frac{dM}{dx} = R_1 - wx - P.$$

If we let $x = a$ in each shear equation,

$$\frac{dM}{dx} = R_1 - wa,$$

$$\frac{dM}{dx} = R_1 - wa - P,$$

the shear just to the left of the load; the shear just to the right of the load.

PROBLEMS.

1. In Fig. 72 calculate $\frac{dM}{dx}$ for both equations at the point x equals 3 feet.

Compare results with the slope of the tangent to the curve and with the ordinates of the shear diagram.

2. Solve Problem 1 for the 8-foot position.

48. Area of Shear Diagram Equals Moment. — Since

$$S = \frac{dM}{dx}, \quad S dx = dM, \quad \text{and} \quad \int S dx = \int dM = M. \quad \text{Formula VI.}$$

In Fig. 75, I, $S dx$ is the area of a vertical strip of the shear diagram of height S and width dx . The integral of $S dx$ between the limits O and x_1 is the area bounded by the shear diagram, the X axis, and the ordinate at x_1 . The moment at the point x_1 is the area of the shear diagram to the left of that point. Similarly, the moment at x_2 is the area of the shaded

portion of the shear diagram in Fig. 75, II; and the moment at x_2 is the area of the shaded portion above the X axis minus the shaded portion below the X axis in Fig. 75, III.

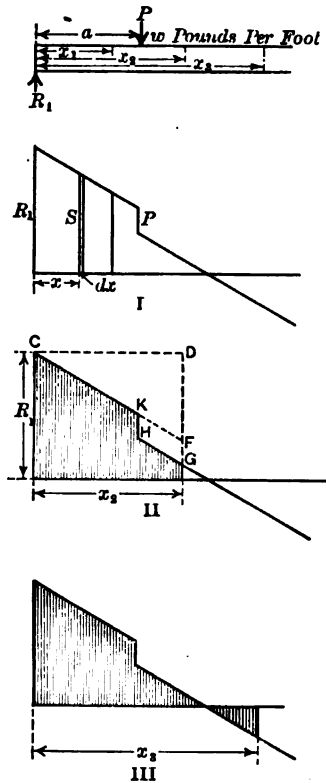

Fig. 75. — Shear Areas.

Let us check this for Fig. 75, II. Writing the moment equation for the section at a distance x_2 from the left support:

$$M = R_1 x_2 - \frac{w x_2^2}{2} - P(x_2 - a) \quad (1)$$

$R_1 x_2$ is the area of the rectangle x_2 long by R_1 high;

$\frac{w x_2^2}{2}$ is the area of the triangle CDF ;

$P(x_2 - a)$ is the area of the parallelogram $FGHK$;

hence the moment equals the area of the shear diagram in this case.

PROBLEMS.

1. In Fig. 70, calculate the moment at the middle by means of the area of the shear diagram. Find also the moment at one-fourth the length and at three-fourths the length from the left end.
2. In Fig. 71, find the moment at 1 foot from the left end by means of the area bounded by the shear line, the X axis, and the ordinates $x = 0$ and $x = 1$ foot.
3. In Fig. 72, find the ordinates of the moment diagram at 3 feet and at 4 feet from the left end by means of the corresponding areas of the shear diagram.
4. In Fig. 72, find the moment at 3 feet and the moment at 6 feet.
5. Without computing the moments at either position, show that the moment at 2 feet, in Fig. 72, is 60 foot pounds less than that at 7 feet.

Since the area of the shear diagram to the left of any point measures the moment at that point, and areas below the X axis are regarded as negative, the moment has its greatest numerical values at points where the shear is zero. This is true whether the shear crosses the axis obliquely, giving a true mathematical maximum or minimum, or crosses vertically under a concentrated load or over a support. These points of zero shear are called the *dangerous sections* in a beam.

PROBLEMS.

In the problems below, compute the moments by means of the shear diagram and check by the moment equations.

6. A beam 12 feet long weighing 100 pounds per foot is supported at the left end and 2 feet from the right end, and carries a load of 600 pounds 2 feet from the left end. Calculate the moment under the concentrated load and at the dangerous sections.
7. A beam 20 feet long, supported at the ends, carries a distributed load, including its own weight, of 120 pounds per foot, and two concentrated loads, 600 pounds 4 feet from the left end and 720 pounds 5 feet from the right end. Find the moment at the dangerous section and under each concentrated load.
Ans. At dangerous section, $M = 9015$ foot pounds.
8. A cantilever fixed at the right end projects 8 feet and carries a distributed load, including its own weight, of 60 pounds per foot and a load of 300 pounds 2 feet from the left end. Construct the moment and shear diagrams: 1 inch equals 1 foot; 1 inch equals 200 pounds shear; 1 inch equals 1000 foot pounds of moment. Where is the dangerous section?
9. A beam 14 feet long weighing 30 pounds per foot is supported 4 feet from the left end and held in a horizontal position by a downward force at the left end. Draw the shear and moment diagrams.
10. A cantilever beam weighing 20 pounds per foot is fixed at the left end and projects 10 feet. Construct the moment and shear diagrams.

We must construct the shear diagram from the free end. We may also begin at the right end to get the moment diagram. Or we may begin at the

wall to get the moment, if we remember that there must be a negative shear area in the wall equal to the triangle outside. If the beam touches the wall at two points *A* and *B* (Fig. 76), the problem is the same as that of Problem 9.

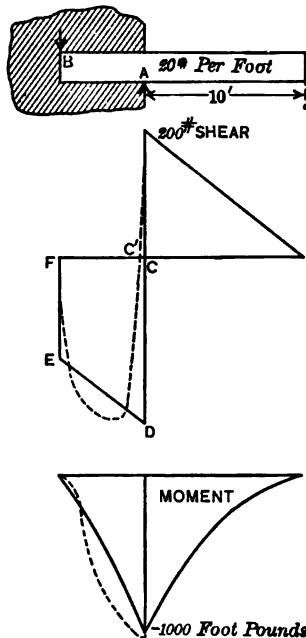

Fig. 76. — Cantilever Fixed at Left End.

The shear diagram is *CDEF*. If the contact is distributed, the shear diagram is that shown by the dotted lines, and the dangerous section is at *C'*, a little to the left of the face of the wall.

11. A beam is supported at the ends and carries two equal concentrated loads at one-third the length from the left end and one-third the length from the right end. Draw moment and shear diagrams, neglecting the weight of the beam.
12. A beam 12 feet long is supported 3 feet from the ends. The total load is 60 pounds per foot. Construct the shear and moment diagrams: 1 inch equals 2 feet length, 100 pounds shear, and 100 foot-pounds moment.

Lewis P. McGilvary
Elect. Eng. 1916

CHAPTER VI.

STRESSES IN BEAMS.

49. **Nature of Stresses.** — In the experiments described in Article 44, we found tension at the top of the cantilever beam and compression at the bottom. With the beam supported at the ends, we were obliged to put the chain below and the cylinder above. In each case, the compression was at the concave side and the tension at the convex side. At any section in a bent beam the fibers in the convex side are elongated and those in the concave side are compressed. Between these, there is a surface which remains unchanged in length. This is called the *neutral surface*.

Fig. 77 represents a beam supported at the ends and bent by its own weight or other loads between the supports. (The amount of bending is exaggerated.) The points B, B', C, C' , lie on the neutral surface. The transverse lines joining B to B' and C to C' are *neutral axes* for their respective sections. Experiments show that a plane section such as EFG remains plane when the beam is bent. In Fig. 77, the dotted lines $K'M', M'N'$ indicate the position, before the beam was bent, of a plane section parallel to EFG . After bending, its position with reference to EFG is shown by the plane KMN . The change consists of a rotation of the plane KMN through an angle $\Delta\theta$ about the neutral axis CC' from the position $K'M'N'$ to the position KMN . (There is also a slight vertical shift in position, but this does not affect the problem.) If we consider a portion of length Δl extending from the plane EFG to the plane KMN , we find that the fibers at the bottom are elongated an amount equal to the distance from N' to N , and those at the top are shortened an amount equal to the distance from M' to M . In the figure a filament of infinitesimal cross section dA is shown at a distance v above the neutral surface. This filament is compressed an amount $v\Delta\theta$ when the beam is bent. If v is negative, the deformation becomes an elongation. (We use v to represent the distance of any element of area above the

neutral surface, and reserve y to represent the deflection of the beam from its original position.)

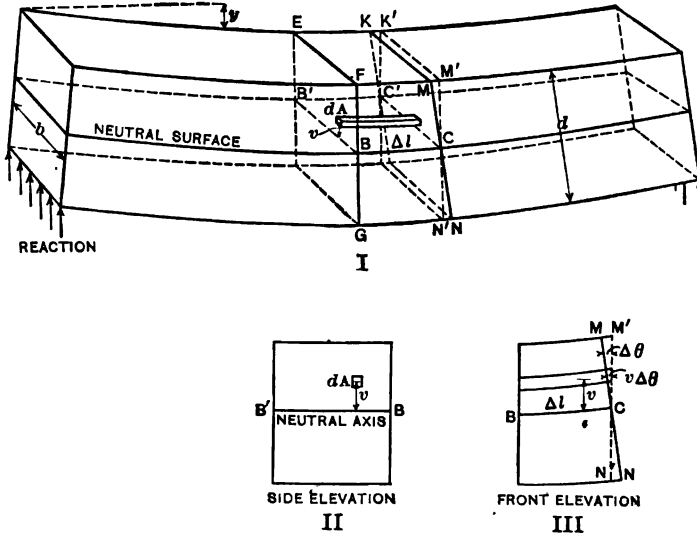

Fig. 77. — Deformation of a Bent Beam.

To get some idea of the magnitude of the quantities involved, let us consider Fig. 78. This represents a beam 6 inches wide and 8 inches deep, and about 7 feet long, supported at two points about 80 inches apart. An extensometer (not shown) is attached at two points, F' and M , 40 inches apart and 1 inch below the top of the beam. A second extensometer is attached at G and N , 1 inch from the bottom. Two loads of 4000 pounds each are applied 16 inches from the supports. If the beam is made of

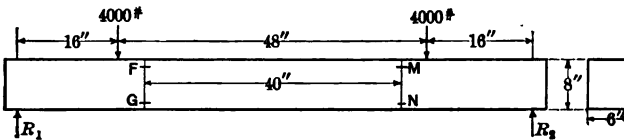

Fig. 78.

timber, the deflection at the middle is about 0.08 inch. (This deflection is too small to show in the drawing unless the scale is exaggerated.) The upper extensometer shows a shortening of about 0.0180 inch in the original length of 40 inches, and the

lower extensometer shows an equal elongation. If the tension and compression are exactly equal, the neutral surface is midway between the extensometers. If the readings are unequal, the location of the neutral surface may be found from the similar triangles, such as MCM' , NCN' (Fig. 77), with MM' and NN' known from the extensometer readings, and the distance between the instruments equal to MN . In case the readings are each 0.0180 inch, showing that the neutral axis is at the middle of the section, 4 inches from the top, the compression in the top fibers is four-thirds as great as at M . The compression at 1 inch from the neutral surface is 0.0060 inch; and at a distance v it is 0.0060 v . The unit deformation at a distance v from the neutral axis is 0.00015 v .

PROBLEMS.

1. A beam is tested as shown in Fig. 78. The points F and M are 40 inches apart and 6 inches above the similar points G and N . The compression reading on the upper instrument is 0.0198 inch, and the extension on the lower instrument is the same. What is the unit stress 4 inches above and 4 inches below the neutral surface, if E equals 1,500,000 pounds per square inch?

Ans. 990 pounds per square inch.

2. In Problem 1, what is the unit stress at a distance unity and at a distance v from the neutral surface?

3. In a case similar to Problem 1, the upper instrument shows a compression of 0.0140 inch and the lower instrument an extension of 0.0160 inch. If the beam is 8 inches deep how far is the neutral surface from the top surface? What is the unit stress at the top and at the bottom of the beam?

Ans. 3.8 inches from the top; s_c equals 0.000475 E_c .

50. Relation of Moment to Stress. — In Fig. 77, let Δl represent the original distance between the planes EFG and $K'M'N'$. This is the distance BC in the figure. Consider a filament of cross section dA connecting these planes at a distance v above the neutral surface. The cross section of this filament may be of infinitesimal dimensions in both directions, as in Fig. 77, or it may be of infinitesimal height dv and extend the entire width of the beam. If this filament is above the neutral axis (in a beam concave upwards), it is shortened an amount $v\Delta\theta$, and if it is below the neutral axis it is lengthened $v\Delta\theta$ when the beam is bent. The unit deformation, being the ratio of the total deformation to the original length, is:

$$\delta = \frac{v\Delta\theta}{\Delta l}. \quad (1)$$

The unit stress in a filament is the product of the unit deformation by the modulus of elasticity:

$$s = Ev \frac{\Delta\theta}{\Delta l}. \quad (2)$$

The total stress on a filament of area dA is the product of the unit stress by the area:

$$\text{total stress on } dA = Ev \frac{\Delta\theta}{\Delta l} dA. \quad (3)$$

The moment of this stress with respect to the neutral axis BB' is the product of the total stress on dA by the moment arm v ;

$$\text{moment of stress about axis} = Ev^2 \frac{\Delta\theta}{\Delta l} dA = E \frac{\Delta\theta}{\Delta l} v^2 dA = dM. \quad (4)$$

The total moment of all the filaments which make up the beam is the integral of dM over the section EFG . Integrating over this area, $\frac{\Delta\theta}{\Delta l}$ remains constant and

$$M = E \frac{\Delta\theta}{\Delta l} \int_{v_1}^{v_2} v^2 dA = E \frac{\Delta\theta}{\Delta l} I, \quad (5)$$

where v_1, v_2 are the distances of the lower and upper surfaces of the beam from the neutral surface, I is the moment of inertia of the cross section EFG or KMN with respect to its neutral axis, and $\Delta\theta$ is the change in slope of the normal to the beam, or the change in slope of the tangent to the beam, in the length Δl .

51. Unit Stress in the Outer Fibers. — The extreme upper and lower fibers in a beam which is bent in a vertical plane suffer the greatest deformations and are subjected to the greatest stress. The allowable unit stress in these fibers determines the load which the beam can safely carry.

The unit stress in any fiber at a distance v from the neutral axis is:

$$s = E \frac{\Delta\theta}{\Delta l} v;$$

$$E \frac{\Delta\theta}{\Delta l} = \frac{s}{v}.$$

Substituting in equation (5) of Article 50,

$$M = \frac{sI}{v}, \quad \text{Formula VII.}$$

$$s = \frac{Mv}{I}. \quad \text{Formula VIII.}$$

s is the unit stress at a distance v from the neutral axis. In Fig. 77, s is positive (compression) when v is positive, and s is negative (tension) when v is negative. When v becomes v_2 , Formula VIII gives the unit stress in the outer (top) fibers. In these equations, M is the resisting moment of all the fibers and is equal to the external moment. Notice in Fig. 77 that the compression in the top fibers and the tension in the bottom fibers at the section EFG both turn counterclockwise about the axis BB ; the resisting moment is negative and the external moment is positive.

Notice that this discussion assumes that the modulus of elasticity is constant for all stresses used and is the same in compression and in tension.

The theory of Articles 50 and 51 may be given more briefly. Let k be the unit stress at unit distance from the neutral axis. At a distance v from the neutral axis,

$$s = kv. \tag{2}$$

On an increment of area dA ,

$$\text{total stress} = kv dA. \tag{3}$$

The moment of this total stress with respect to the neutral axis is

$$dM = \text{total stress on } dA \text{ multiplied by } v = kv^2 dA, \tag{4}$$

which is positive for all values of v when k is positive and vice versa.

$$M = \int kv^2 dA = kI. \tag{5}$$

If s_1 is the unit stress at a distance v_1 from the neutral axis $s_1 = kv_1$,

$$k = \frac{s_1}{v_1}. \tag{6}$$

Substituting (6) in (5):

$$M = \frac{s_1 I}{v_1}. \tag{Formula VII.}$$

While Formula VIII may be obtained at once from VII, they are of such importance that both should be memorized.

52. Location of the Neutral Axis. — We have yet to obtain the position of the neutral axis. To do this, we make use of the fact that the total tensile stress across the section EFG below the neutral axis is equal to the total compressive stress above the neutral axis.

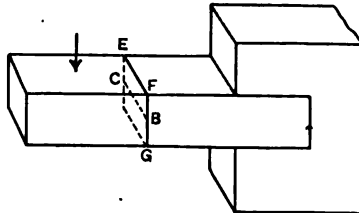

Fig. 79.

Consider Fig. 79, a horizontal cantilever. Take the forces

which act on the portion on the left of the section EFG , and resolve horizontally. Since the external force has no horizontal component, the only forces to be considered are the internal forces at the section. The portion is in equilibrium, hence the total compressive force across the section below the neutral axis must equal the total tensile force across the section above the axis.

$$\text{Stress on } dA = kv \, dA, \quad (1)$$

which has the same sign as k when v is positive and the opposite sign when v is negative.

$$\text{Total stress on entire section} = k \int_{v_1}^{v_2} v \, dA = 0; \quad (2)$$

k is not zero when the beam is bent, hence

$$\int v \, dA \text{ must equal zero.} \quad (3)$$

In Mechanics we learned that the position of the center of gravity of a plane area is given by

$$\bar{y} = \frac{\int y \, dA}{A},$$

$$\bar{v} A = \int v \, dA. \quad (4)$$

The second member of equation (4) is zero, hence

$$vA = 0,$$

Since A is not zero

$$\bar{v} = 0.$$

The neutral axis in a beam of any section passes through the center of gravity of the section.

This is on the assumption that the modulus of elasticity is constant for all stresses used, and is the same in compression and tension. Where the beam is stressed beyond the elastic limit, this is not strictly true. Since working loads should be well within the elastic limit, these results are strictly correct in well-designed structures.

PROBLEMS.

1. A beam 4 inches wide, 6 inches deep, and 10 feet long is supported at the ends. Find the unit stress in the top and bottom fibers at the middle of its length due to a load of 400 pounds at the middle.

The moment at the middle is 1000 foot pounds. The moment of inertia of the cross section with respect to the neutral axis is 72 inches⁴. $\frac{I}{v}$ equals 24 inches³ for both top and bottom fibers. The external moment and $\frac{I}{v}$ must

be expressed in the same units. Since we express stress in pounds per square inch, we reduce the moment to inch pounds to use in Formula VIII.

Ans. $s = 500$ pounds per square inch.

2. A beam 6 inches wide, 8 inches high, and 15 feet long is supported at the ends and carries a uniformly distributed load, including its own weight, of 160 pounds per foot. Find the maximum moment in inch pounds and the maximum fiber stress.

Ans. Maximum fiber stress, 844 pounds per square inch.

3. A 10-inch 25-pound I-beam is supported at two points 13 feet 4 inches apart and carries a load of 6000 pounds midway between the supports. Neglecting the weight of the beam, find the maximum fiber stress under the load. (See Cambria for the moment of inertia of I-beams.)

Ans. 9830 pounds per square inch.

53. **Section Modulus.** — The expression $\frac{I}{v}$, where v is the distance to the extreme outer fiber, is used so often that it is convenient to give it a name. It is called the *section modulus*, or *modulus of the section*. Formula VIII becomes

$$\text{unit stress in extreme fibers} = \frac{\text{external moment}}{\text{section modulus}}$$

The value of the section modulus for I-beams and channels is given in Cambria in column 8 of the properties of these shapes. It is convenient to know the section modulus of a rectangular section. If the breadth is b and the depth is d , the moment of inertia is $\frac{bd^3}{12}$, and v is $\frac{d}{2}$; hence the modulus of the section is:

$$\frac{I}{v} = \frac{bd^2}{6}. \quad \text{Formula IX.}$$

PROBLEMS.

1. How much stronger is a beam 6 inches wide and 8 inches deep, than a beam of the same material 4 inches wide and 6 inches deep? *Ans.* 8 : 3.

2. Compare the strength of a 4-inch by 6-inch beam with the 6-inch side vertical, with that of the same beam with the 4-inch side vertical.

3. Show that the ratio of the strength of a beam of rectangular section with the side b vertical to its strength with the side d vertical is $\frac{b}{d}$.

4. A 4-inch by 6-inch cantilever projects 6 feet from a wall and carries a distributed load of 40 pounds per foot and a load, P , 3 feet from the free end. What is the maximum value of P if the fiber stress shall not exceed 1000 pounds per square inch? *Ans.* 427 pounds.

(In giving dimensions, horizontal are given first. A 4-inch by 6-inch beam is 4 inches wide and 6 inches deep.)

5. Find the I-beam for a span of 15 feet with a uniformly distributed load, including the weight of the beam, of 600 pounds per foot, and a load of 4000 pounds at the middle, with allowable stress 13,500.

Ans. The section modulus is 28.3. Use a 10-inch 35-pound I-beam, or a 12-inch 31.5-pound I-beam. The latter is cheaper and stronger, and should be used unless the 2 inches of head room is important.

6. A 15-inch 45-pound I-beam, supported at the ends, is used for a 20-foot span to carry a uniformly distributed load, including its own weight, of 500 pounds per foot, and a load of 3000 pounds 4 feet from the left support. Find the maximum fiber stress. *Ans.* 6189 pounds per square inch.

7. Find the I-beam for a span of 20 feet to carry a uniformly distributed load, inclusive of its own weight, of 600 pounds per foot and two concentrated loads, 2000 pounds 3 feet from the left support and 3000 pounds 4 feet from the right support, if the allowable unit stress is 12,500 pounds per square inch.

Ans. A 12-inch 35 pound I-beam.

8. A wooden beam is used for a span of 12 feet 6 inches to carry a load of 4000 pounds at the middle. If the breadth of the beam is 8 inches and the allowable working stress is 1000 pounds per square inch, what is the minimum depth?

9. A yellow-pine beam 6 inches wide, 10 inches deep, and 20 feet long is supported at the left end and 4 feet from the right end and carries a distributed load, including its own weight, of 120 pounds per foot and two concentrated loads, 1200 pounds 2 feet from the left end and 400 pounds at the right end. Construct the shear diagram. Find the moment at each dangerous section, and the maximum fiber stress.

Ans. Maximum fiber stress, 499 pounds per square inch.

10. In Problem 9 there is a point between the first dangerous section and the right support at which the moment is zero. Find this position by writing the moment equation in terms of the distance from the left end and equating to zero. Solve also by means of the shear diagram, making use of the fact that the area of the shear diagram between the point to be found and the first dangerous section is equal to the area to the left of this dangerous section.

11. Using New York building laws, calculate the maximum allowable load, uniformly distributed, on a 2-inch by 12-inch floor joist of long-leaf yellow pine, of 16 feet 8 inches span. *Ans.* 2304 pounds, 138 pounds per foot.

12. If the weight of the joist, flooring, and plastering, in Problem 11, is 20 pounds per square foot, is the construction allowable for a school building with joists spaced 12 inches center to center?

13. Find the maximum span, according to New York building laws, for a 2-inch by 10-inch long-leaf yellow-pine joist supporting a distributed load, including its own weight, of 120 pounds per foot. *Ans.* 14.9 feet.

14. What is the maximum span for a 20-inch 65-pound I-beam supporting a uniformly distributed load, including its own weight, of 1500 pounds per foot, if the allowable unit stress is 13,500 pounds per square inch?

Ans. 26 feet 6 inches.

15. Determine the moment of inertia of a circular section of radius a , and show that the section modulus is $\frac{\pi a^3}{4}$.

16. What is the section modulus of a 6-inch square with the diagonal ver-

tical? How does it compare with the section modulus of the same section with one side vertical? *Ans.* Section modulus, 25.45; ratio, $1 : \sqrt{2}$.

→ 17. A square section with diagonal vertical has its section modulus increased by chamfering the top and bottom corners. What must be the dimensions of the triangular sections cut away, in terms of the side of the square, to make the section modulus a maximum?

18. A wooden box girder is made of two 2-inch by 12-inch planks and two 2-inch by 8-inch planks. What is the section modulus when these are united to form a girder of square section? *Ans.* 231 inches³.

19. A box girder is made of two 10-inch 15-pound channels and two 12-inch by $\frac{1}{2}$ -inch plates. What is the section modulus with the channels vertical? (Take I of channels from table in Cambria.)

20. A 6-inch by 8-inch cantilever 10 feet long is placed with its 8-inch faces 30 degrees to the vertical and a load of 200 pounds applied at the free end. Find the maximum fiber stress at the corners.

Ans. 574.7 pounds per square inch.

Resolve the force or the moment perpendicular and parallel to the principal axes of inertia. Find unit stress separately and add.

54. Graphic Representation of Stress Distribution. — The unit stress in a beam, provided it does not exceed the elastic limit, varies as the distance from the neutral axis. It may be represented by the straight line EF of Fig. 80. This straight

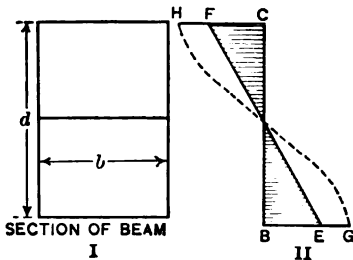

Fig. 80. — Variation of Stress in Section.

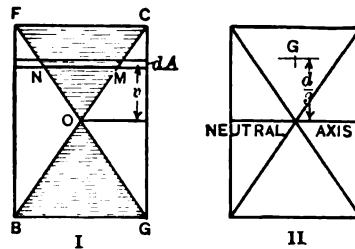

Fig. 81. — Stress Distribution in a Rectangular Section.

line is really a part of the straight-line portion of the stress diagram for both tension and compression, while the vertical line BC is the X axis. If the stress is carried beyond the elastic limit, the dotted line GH represents its distribution in the beam.

In a beam of rectangular section, the total stress on any area dA , extending across the section, is proportional to the unit stress. The shaded area of Fig. 80 may represent the total stress in a rectangular section as well as the unit stress in a section of any form. It is often convenient to represent total stress

in a rectangular section by a figure similar to the shaded area in Fig. 81. This is really the same as Fig. 80 with oblique axes. The line FC represents the breadth of the section and also the total stress in the extreme outer fibers. It is evident, from the similar triangles, that the total stress on the area dA , extending across the section at a distance v from the neutral axis, will be to the total stress at the top, as the length MN is to the length FC . The actual stress over the entire section is equal to a uniform stress of intensity equal to that in the outer fibers over the shaded area. If the cross section is drawn to full scale, the area of the shaded triangle OFC gives the total stress above the neutral surface when the maximum stress is 1 pound per square inch. Likewise, the area OBG gives the total stress below the neutral surface. These triangular areas are equal in magnitude and opposite in sign, making the sum of the total stress zero.

The section modulus of a rectangular section may be computed from these diagrams. The area of the triangle OFC is $\frac{bd}{4}$. A uniform stress of intensity unity over the entire triangle would have a resultant $\frac{bd}{4}$ at the center of gravity of the triangle. The moment of the upper half with respect to the neutral axis is

$$\frac{bd}{4} \cdot \frac{d}{3} = \frac{bd^2}{12}$$

The moment of the lower half is the same and rotates in the same direction (since both stress and moment arm change signs).

The total moment is $\frac{bd^2}{6}$.

When the unit stress in the outer fibers is s instead of unity total moment = $\frac{sb d^2}{6}$.

We will now draw the stress distribution for an I-beam section. This diagram for the rectangular portion of the flange is drawn like Fig. 81. Now take a small area dA , Fig. 82, in the web. The total stress in this area is to the total stress in a similar area JK at the top as the distance of dA from the neutral axis is to the distance of JK from this axis. To get the total stress on dA , we first project its length on the upper surface to locate the points JK . Then draw straight lines from the center O to J and K .

The part of dA between these lines represents the total stress. To get the stress on the triangular portion of the flange, consider the portion ST drawn (for convenience) in the lower flange. Project S and T on the lower line and connect the center O with the points thus found by means of the dotted lines. The portion $S'T'$ between these lines measures the total stress. A number of these lines will give the curved area required.

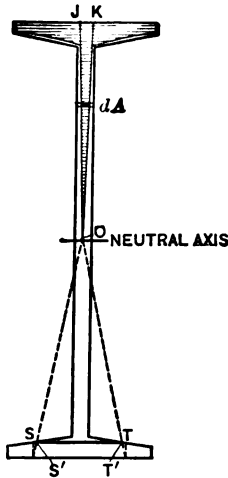

Fig. 82. — Stress Distribution in an I-beam.

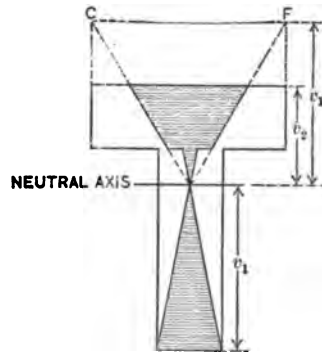

Fig. 83. — Distribution in a T-section.

Fig. 83 is the stress distribution in a T shaped section. The lower portion is constructed like Fig. 81. The outer fibers at the top are nearer the neutral axis than those at the bottom. Instead of projecting on the upper line of the section, we project on a line CF whose distance from the neutral axis is the same as the lower fibers. The total stress in this diagram is expressed in terms of the unit stress in the bottom fibers. We might express the total stress in terms of the unit stress in the top fibers. In that case the lower part of the diagram would extend beyond the section to the right and left.

PROBLEMS.

1. Construct the stress-distribution diagram for a 6-inch by 4-inch by 1-inch angle section, using neutral axis parallel to shorter leg.
2. A beam 12 inches deep is constructed of one 12-inch by $\frac{1}{2}$ -inch plate and four 4-inch by 3-inch by $\frac{1}{4}$ -inch angles with shorter legs parallel to the plate. Construct the stress-distribution diagram.

3. Construct the stress-distribution diagram for a 6-inch by 8-inch rectangular section with the 6-inch side horizontal. Calculate from the diagram the total stress in the upper strip 1 inch high and 6 inches wide as compared with the total stress in a similar strip touching the neutral axis.

55. **Stress Beyond the Elastic Limit.** — In Fig. 85 the shaded area shows the distribution of stress in a rectangular section, when the stress is considerably beyond the elastic limit. The actual stress in the outer fibers is less than it would be if the modulus were constant in the ratio of the lengths $CH:CF$. The moment of resistance is also less.

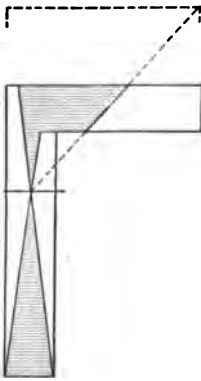

Fig. 84. — Distribution in an Angle Section.

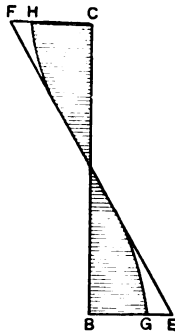

Fig. 85.

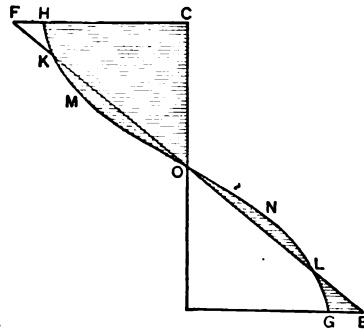

Fig. 86. — Rectangular Section Beyond the Elastic Limit.

Fig. 86 represents the stress distribution when the elastic limit is exceeded as compared with a beam of constant modulus having the same *resisting moment*. The moment of the curved area $OMKHC$ must equal the moment of the triangular area OFC . From the center of the section to the point K the curve lies outside of the straight line. Beyond K it is inside. The unit stress in the fibers near the neutral surface is greater than if the modulus were constant; and the unit stress in the outer fibers is less. The moment of the dotted area OMK (or the shaded area ONL) is equal to that of the area KFH or LGE .

56. **Modulus of Rupture.** — When a beam is broken by bending, the stress-distribution diagram for a rectangular section, $OMKH$ (Fig. 86), is similar to the *complete* tension or compres-

sion curve of the material. The actual unit stress in the outer fibers is less than that obtained from the equation

$$s = \frac{Mv}{I} \quad \text{Formula VIII.}$$

in the ratio of $CH:CF$ (Fig. 86.) The *calculated* value of the stress in the outer fibers computed from Formula VIII is called the *modulus of rupture*, or the transverse ultimate strength of the material. It is also called the *extreme fiber stress in bending*.

While the modulus of rupture does not give the actual stress, it enables us to compare stresses in similar sections. If the modulus of rupture is obtained from the test of beams of rectangular section, this figure may be used in computing the ultimate transverse load in other beams of rectangular section made of the same material. The results may also be used with little error for beams of other shapes, provided they are symmetrical with respect to the neutral axis. With unsymmetrical sections, such as angles, it is better to make tests and obtain the modulus of rupture for each shape.

The student will remember, however, that these statements apply to the stress beyond the elastic limit. Since allowable stresses are below the elastic limit, Formula VIII is strictly correct for allowable loads. The change in the stress-distribution diagram when the stress passes the elastic limit *affects* the *factor of safety only*.

Ductile materials, such as soft steel, have no modulus of rupture, strictly speaking, since beams of such material may be bent double without breaking.

PROBLEMS.

1. A white-pine beam 1.78 inches wide and 1.25 inches thick was supported at two points 12 inches apart and broken by a load at the middle. The total load at rupture was 1112 pounds. Find the modulus of rupture.

Ans. 7200 pounds per square inch.

2. If white pine of quality equal to that of Problem 1 is used in the form of a 4-inch by 4-inch beam to carry a load of 700 pounds midway between two supports 6 feet apart, what is the factor of safety?

3. A rectangular bar of cast iron 1.04 inches wide and 0.80 inch thick is placed on two supports 12 inches apart and broken by a load of 1635 pounds at the middle. What should be the allowable working stress in this cast iron in beams of rectangular section with a factor of safety of 10?

Ans. 4400 pounds per square inch.

4. A beam of short-leaf yellow pine, tested by Prof. A. N. Talbot at the University of Illinois, had the following dimensions: breadth, 7.12 inches; depth, 16.25 inches; distance between supports, 13 feet 6 inches. Two equal loads were applied at points 4 feet 6 inches from the supports, making the bending moment constant and the shear zero between these points (if the weight of the beam is neglected). The beam broke by tension in the outer fibers between the loads when each load was 27,500 pounds. Find the modulus of rupture.

Ans. 4739 pounds per square inch.

5. A beam of long-leaf yellow pine 7.0 inches wide and 14.0 inches deep, supported and loaded as in Problem 4, broke under a total load of 37,300 pounds. What was the ultimate bending strength of this timber?

Ans. 4400 pounds per square inch.

6. A second beam of long-leaf yellow pine 7.0 inches by 12.1 inches, supported and loaded as above, broke under a total load of 52,900 pounds. What was the ultimate bending strength of this timber?

Ans. 8362 pounds per square inch.

Problems 4, 5, and 6 are from Bulletin 41 of the University of Illinois Engineering Experiment Station.

7. A 5-inch by 6-inch beam of 1 : 2 : 4 concrete, placed on supports 32 inches apart, was broken by a load of 1300 pounds midway between the supports. Neglecting the weight of the beam, find the modulus of rupture.

Ans. 347 pounds per square inch.

CHAPTER VII.

DEFLECTION IN BEAMS.

57. **Deflection and Moment.** — In Article 50, equation (5), we have:

$$M = EI \frac{\Delta\theta}{\Delta l} = EI \frac{d\theta}{dl} \quad (1)$$

for infinitesimal lengths dl , measured along the neutral surface of the bent beam. The angle $d\theta$ is the change in slope of the tangent to the neutral surface in the length dl . We will now determine the relation existing between the moment and the deflection of the beam from its original form. This is especially easy in polar coordinates. The lines FG and MN , of Figs. 87

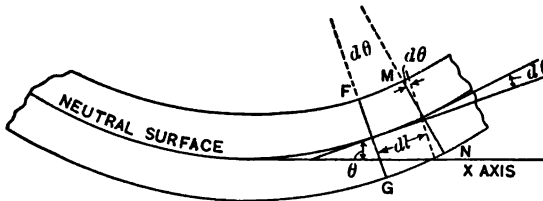

Fig. 87. — Curvature of Beam.

and 77, make an angle $d\theta$ with each other (when Δl becomes dl), and intersect at some point beyond the drawing, at a distance ρ from the neutral surface. This distance ρ is the radius of curvature of the neutral surface.

By geometry:

$$\rho d\theta = dl, \quad (2)$$

$$\frac{d\theta}{dl} = \frac{1}{\rho}. \quad (3)$$

Substituting in (1),

$$\frac{M}{EI} = \frac{1}{\rho}, \quad M = \frac{EI}{\rho}.$$

If M is constant, or if I varies as M , ρ is constant, and the curve of the beam is an arc of a circle which may be computed by trigonometry.

PROBLEMS.

1. A 3-inch by 1-inch steel beam 10 feet long rests on two supports each 30 inches from the ends and carries a load of 200 pounds on each end. Neglecting the weight of the beam, what is the bending moment at the supports? If the modulus of elasticity is 30,000,000, what is the radius of curvature? How much is the beam deflected upward at the middle?

Ans. $\left\{ \begin{array}{l} \text{Moment, 6000 inch pounds;} \\ \text{Radius of curvature, 1250 inches;} \\ \text{Deflection at the middle, 0.36 inch.} \end{array} \right.$

SUGGESTION. — With the radius of curvature known, calculate the angle in radians subtended by half the span. The versed sine of this angle multiplied by the radius of curvature is the deflection at the middle. As ordinary tables are of little value for such small angles, it is recommended that the student use the first two terms of the cosine series to get this versed sine. (See trigonometry for series or develop by Maclaurin's formula.)

2. In Problem 5 of Article 56, if E is 1,500,000, what was the radius of curvature when the total load was 30,000 pounds?

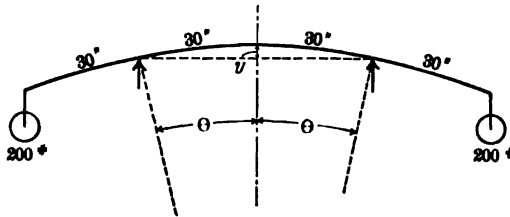

Fig. 88.

58. Deflection in Rectangular Coördinates. — To express the value of $\frac{M}{EI}$ in rectangular coördinates, we must determine $\frac{d\theta}{dl}$ in terms of x and y and their derivatives. Let x express distance parallel to the unbent beam and y express deflection of the beam from its original position. These distances are usually measured along the neutral surface. The angle θ may be measured from any fixed line. For convenience of calculation, we will measure θ from a line parallel to the X axis. The angle θ is then the angle which the tangent to the curved beam makes with the original direction of the beam. It is the angle through which the tangent to the beam at any point is turned when the beam is bent.

Fig. 89 shows a beam supported at the ends and bent. The lower figure represents the neutral axis with the vertical deflection exaggerated. The origin is taken at the left support, and x is

taken as positive to the right and y as positive upwards, as is the custom in mathematical work.

From Fig. 89 (or the Calculus):

$$\tan \theta = \frac{dy}{dx}, \tag{1}$$

$$\theta = \tan^{-1} \frac{dy}{dx}. \tag{2}$$

Differentiating (2):

$$\frac{d\theta}{dx} = \frac{\frac{d^2y}{dx^2}}{1 + \left(\frac{dy}{dx}\right)^2}. \tag{3}$$

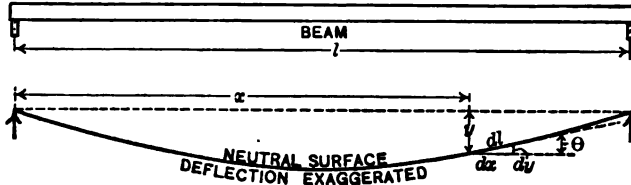

Fig. 89.

From Fig. 89, $dx = dl \cos \theta$, which, substituted in (3), gives:

$$\frac{d\theta}{dl} = \frac{\frac{d^2y}{dx^2}}{1 + \left(\frac{dy}{dx}\right)^2} \cos \theta = \frac{\frac{d^2y}{dx^2}}{\left\{1 + \left(\frac{dy}{dx}\right)^2\right\}^{\frac{3}{2}}}, \tag{4}$$

since $\sec \theta = \sqrt{1 + \left(\frac{dy}{dx}\right)^2}$.

Substituting this value of $\frac{d\theta}{dl}$ in (1) of Article 57:

$$M = EI \frac{\frac{d^2y}{dx^2}}{\left\{1 + \left(\frac{dy}{dx}\right)^2\right\}^{\frac{3}{2}}}. \tag{5}$$

Equation (5) may be obtained direct from (4) of Article 57 if the student remembers the expression for the radius of curvature from his Calculus.

In beams, as used in engineering practice, the deflections allowed are small, and $\frac{dy}{dx}$ is usually so small compared with unity that it may be dropped from the denominator of equation (5). It seldom happens that $\frac{dy}{dx}$ is greater than 0.01. This makes $\left(\frac{dy}{dx}\right)^2$ not greater than 0.0001, and the error in dropping it entirely from the denominator is not more than one part in 7000. Equation (5) then becomes:

$$M = EI \frac{d^2y}{dx^2}. \quad \text{Formula X.}$$

Formula X is the differential equation which enables us to calculate the deflection of a beam or column. The X axis must be parallel to the direction of the unbent beam and $\frac{dy}{dx}$ must be so small that its square is negligible compared with unity.

To determine the deflection of a beam, we must solve this differential equation for y in terms of x and the constants. Where E and I are constant this means that we must express M in terms of x and y and solve. When all the loads are vertical and the beam horizontal, or in general, when all loads and reactions are perpendicular to the unbent beam, M may be expressed in terms of x alone. Our problem then is to solve a differential equation of the *second order and first degree* of the form

$$\frac{d^2y}{dx^2} = \text{function of } x.$$

To solve this we merely integrate twice. There are two constants of integration which must be determined from the conditions of the problem. There are two things to be done in solving these problems. The first is to write an expression for the moment at *any point* in terms of x and the known loads and reactions. The second is to determine two conditions from which the two integration constants may be evaluated.

59. Beam Supported at Two Points; Moment Constant.—

This is the case shown in Fig. 90. A beam rests on two supports at a distance l apart, overhangs these supports, and carries loads on the free ends which make the moment at each support the same ($Pc = Qe$). Let M be the value of this moment. If the weight of the beam is neglected, the moment is constant through-

out the span of length l from one support to the other. We will consider this portion only. Remembering that the sign of the moment is negative and substituting in Formula X:

$$EI \frac{d^2y}{dx^2} = -M. \quad (1)$$

Integrating:

$$EI \frac{dy}{dx} = -Mx + C_1. \quad (2)$$

Integrating again:

$$EIy = -\frac{Mx^2}{2} + C_1x + C_2. \quad (3)$$

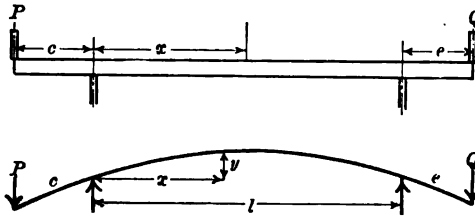

Fig. 90. — Beam with Constant Moment.

To obtain the constants C_1 and C_2 , we have the condition that $y = 0$ at the left support where $x = 0$. Substituting in equation (3), we get:

$$\begin{aligned} C_2 &= 0; \\ EIy &= -\frac{Mx^2}{2} + C_1x. \end{aligned} \quad (4)$$

Equation (4) is true for all values of x for which the moment is $-M$. It is true at the right support, where $x = l$ and $y = 0$. Substituting in (4):

$$0 = -\frac{Ml^2}{2} + C_1l, \quad C_1 = \frac{Ml}{2}.$$

Substituting this value of C_1 in equation (4), we get:

$$EIy = -\frac{Mx^2}{2} + \frac{Mlx}{2}, \quad (5)$$

$$y = -\frac{M}{2EI}(x^2 - lx) = \frac{M}{2EI}(lx - x^2). \quad (6)$$

Equation (6), which gives the value of y in terms of x and the constants EI and M , for all values of x between the supports, is

called the *equation of the elastic line* of the beam between these points. To find the position of maximum deflection, let $\frac{dy}{dx} = 0$ in equation (2). After substituting the value of C_1 , we get:

$$\frac{dy}{dx} = \frac{M}{EI} \left(\frac{l}{2} - x \right),$$

$$\frac{dy}{dx} = 0 \quad \text{when} \quad x = \frac{l}{2},$$

hence the point of maximum deflection is at the middle of the span. Substituting in (6), to get the maximum deflection at the middle:

$$y_{\max} = \frac{Ml^2}{8EI}. \quad (7)$$

It is evident that if the loads P and Q are equal and the lengths c and e are equal, the beam would be symmetrical with respect to the middle of the span; and that this point would be the position of maximum deflection. In that case we could set $\frac{dy}{dx}$ equal to 0 when x equals $\frac{l}{2}$ in equation (2) and solve for C_1 before integrating the second time. If P and Q are not equal, but the products

$$Pc = Qe,$$

the symmetry is not so self-evident, and it is safer to obtain the constants as we have done.

PROBLEMS.

1. Show that the deflection for all parts of the span is positive.
2. Apply equation (7) to Problem 1 of Article 57.
3. Apply equation (6) to the above problem to find the deflection at 10 inches, 20 inches, and 40 inches from the left support.

<i>Ans.</i>	x	y
	10 inches.	0.20 inch.
	20 " "	0.32 " "
	40 " "	0.32 " "

4. In the above problem find the slope of the tangent at either support, and find how much $1 + \left(\frac{dy}{dx}\right)^2$ differs from unity.

Ans. 0.024, -0.024, 0.000576.

5. A 4-inch by 4-inch wooden beam 12 feet long is supported 4 feet from the left end and 3 feet from the right end. A load of 150 pounds is placed on the left end and a load of 200 pounds on the right end. A point midway between the supports rises 0.112 inch when the loads are applied. Find E .

Ans. 1,350,000 pounds per square inch.

60. Cantilever Beam with Load on the Free End.— Fig. 91 represents a cantilever beam fixed at the right end and loaded

at the left end. The origin of coördinates is taken from the left end before the load was applied. The moment at a distance x from the origin is $-Px$. The differential equation becomes:

$$EI \frac{d^2y}{dx^2} = -Px. \quad (1)$$

$$EI \frac{dy}{dx} = -\frac{Px^2}{2} + C_1. \quad (2)$$

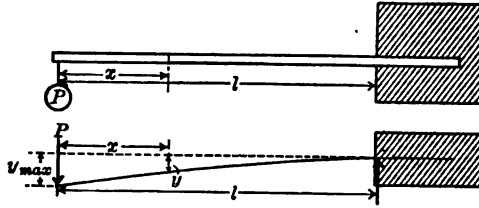

Fig. 91. — Cantilever with Load on Free End.

At the wall, where $x = l$, the beam is horizontal and $\frac{dy}{dx} = 0$;

$$C_1 = \frac{Pl^2}{2}. \quad (3)$$

$$EI \frac{dy}{dx} = -\frac{Px^2}{2} + \frac{Pl^2}{2}. \quad (4)$$

$$EIy = -\frac{Px^3}{6} + \frac{Pl^2x}{2} + C_2. \quad (5)$$

At the wall $x = l$, $y = 0$;

$$0 = -\frac{Pl^3}{6} + \frac{Pl^3}{2} + C_2;$$

$$C_2 = -\frac{Pl^3}{3}. \quad (6)$$

$$EIy = -\frac{Px^3}{6} + \frac{Pl^2x}{2} - \frac{Pl^3}{3}. \quad (7)$$

$$y = -\frac{P}{EI} \left(\frac{x^3}{6} - \frac{l^2x}{2} + \frac{l^3}{3} \right). \quad (8)$$

The maximum deflection is at the free end, where $x = 0$.

$$y_{\max} = -\frac{Pl^3}{3EI}.$$

Formula XI.

PROBLEMS.

1. A wooden cantilever 6 inches square and 10 feet long is deflected 0.64 inch at the end by a load of 180 pounds at the end. Find E and maximum fiber stress.

Ans. E , 1,500,000; maximum stress, 600 pounds per square inch.

2. In Problem 1 what is the deflection 3 feet from the free end?

Ans. 0.36 inch.

3. A cantilever beam 8 feet 4 inches long is deflected 0.2 inch at the end by a load at the end. What is the deflection 30 inches from the free end?

4. A 4-inch by 4-inch wooden cantilever 10 feet long is deflected 1 inch at the end by a load at the end. If E equals 1,200,000 pounds per square inch, what is the maximum fiber stress?

5. A 10-inch I-beam, as a cantilever 8 feet long, is deflected 0.35 inch at the end by a load at the end. If E is 29,000,000, find the maximum fiber stress.

Ans. 16,520 pounds per square inch.

6. If the allowable fiber stress in a wooden beam is 1000 pounds per square inch and the modulus of elasticity is 1,500,000, derive the expression for the deflection at the end of a cantilever of length l and depth d due to the maximum allowable load at the end.

7. A cantilever of length $a + c$ has a load P at a distance a from the fixed end. Find the deflection under the load and at the free end.

8. A cantilever of length $a + c$ has a load P at the free end. Find the deflection at a distance c from the free end.

61. **Cantilever with Uniformly Distributed Load.** — Fig. 92 represents a cantilever with a uniformly distributed load. We

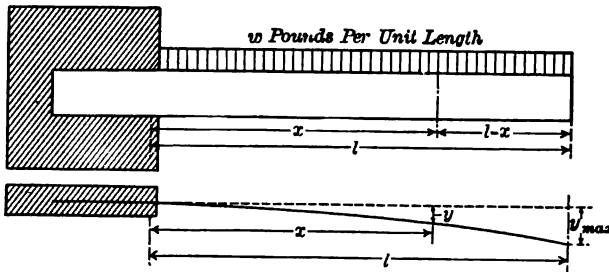

Fig. 92. — Cantilever with Uniformly Distributed Load.

have drawn this cantilever fixed at the left, and taken the origin at the wall. To determine the moment, we use the free end of length $l - x$ to the right of the section at a distance x from the origin. If w is the load per unit length, the weight of this free portion is $w(l - x)$. Its moment arm is $\frac{l - x}{2}$:

$$M = -w \frac{(l - x)^2}{2}.$$

The sign is negative, since the moment with which the left portion tends to turn the right portion is counterclockwise (or the beam is convex upward).

$$EI \frac{d^2y}{dx^2} = -\frac{w(l-x)^2}{2}. \quad (1)$$

$$EI \frac{dy}{dx} = \frac{w(l-x)^3}{6} + C_1. \quad (2)$$

At the wall, where $x = 0$, $\frac{dy}{dx} = 0$;

$$0 = \frac{wl^3}{6} + C_1; \quad (3)$$

$$EI \frac{dy}{dx} = \frac{w(l-x)^3}{6} - \frac{wl^3}{6}. \quad (4)$$

$$EIy = -\frac{w(l-x)^4}{24} - \frac{wl^3x}{6} + C_2. \quad (5)$$

At $x = 0$, $y = 0$:

$$C_2 = \frac{wl^4}{24}, \quad (6)$$

$$EIy = -\frac{w(l-x)^4}{24} - \frac{wl^3x}{6} + \frac{wl^4}{24}. \quad (7)$$

The maximum deflection is at the point where $x = l$;

$$y_{\max} = -\frac{wl^4}{8EI} = -\frac{Wl^3}{8EI}, \quad \text{Formula XII.}$$

where $W = wl$, the total distributed load.

We stated that the maximum deflection is at the point where $x = l$. This is not a mathematical maximum, where the slope of the tangent is zero. It is a numerical maximum because the beam ends at this point. The curves considered in the Calculus are of indefinite extent.

PROBLEMS.

1. What is the deflection at the end of a 6-inch by 6-inch cantilever 12 feet long due to a distributed load of 40 pounds per foot, if E is 1,200,000, and what is the maximum fiber stress?

Ans. $\left\{ \begin{array}{l} \text{Deflection at free end, 1.38 inches;} \\ \text{Fiber stress at wall, 960 pounds per square inch.} \end{array} \right.$

2. If the allowable fiber stress in a wooden beam is 1000 pounds per square inch and the modulus of elasticity is 1,500,000, derive the expression for the deflection at the end of a cantilever of length l and depth d due to uniformly distributed load which develops the allowable stress.

3. How does the deflection of a cantilever with a uniformly distributed load compare with the deflection of a cantilever with a concentrated load at the free end, if the fiber stress is the same in both cases?

4. Expand equation (1) and integrate to get the equation of the elastic line. Then expand equation (7) and compare the results.

5. Take a cantilever fixed at the right end as in Fig. 91, with a uniformly distributed load of w per unit length. With the origin at the free end as in Fig. 91, write the differential equation and solve for the equation of the elastic line. Compare the resulting equation with (7) for points at the free end, at the middle, and at a distance c from the free end.

6. What is the total deflection of a wooden beam 8 inches wide, 6 inches deep, as a cantilever 8 feet 4 inches long, due to a distributed load of 84 pounds per foot and a load of 350 pounds at the free end, if E is 1,400,000? What is the maximum fiber stress? What is the factor of safety if the beam is white oak?
Ans. Deflection at the end, 1.01 inches.

62. **Beam Supported at the Ends, Uniformly Loaded.** — In a beam supported at the ends and uniformly loaded, the end reactions are each equal to one-half of the total load,

$$R_1 = R_2 = \frac{W}{2} = \frac{wl}{2}.$$

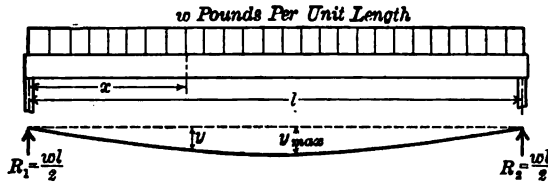

Fig. 93. — Supports at Ends, Load Uniformly Distributed.

The moment at a distance x from the left support is

$$\frac{wlx}{2} - \frac{wx^2}{2},$$

and the differential equation becomes:

$$EI \frac{d^2y}{dx^2} = \frac{wlx}{2} - \frac{wx^2}{2}. \quad (1)$$

$$EI \frac{dy}{dx} = \frac{wlx^2}{4} - \frac{wx^3}{6} + C_1. \quad (2)$$

From symmetry we see that the tangent is horizontal at the middle,

$$\begin{aligned} \frac{dy}{dx} &= 0 \quad \text{when} \quad x = \frac{l}{2}; \\ C_1 &= -\frac{wl^3}{24}; \end{aligned} \quad (3)$$

$$EI \frac{dy}{dx} = \frac{wx^2}{4} - \frac{wx^3}{6} - \frac{wl^3}{24}. \quad (4)$$

$$EIy = \frac{wx^3}{12} - \frac{wx^4}{24} - \frac{wl^2x}{24} + C_2. \quad (5)$$

At $x = 0, y = 0; C_2 = 0;$ (6)

$$EIy = \frac{wx^3}{12} - \frac{wx^4}{24} - \frac{wl^2x}{24}. \quad (7)$$

When $x = \frac{l}{2}$ the deflection is a maximum

$$EIy_{\max} = \frac{wl^4}{12} \left(\frac{1}{8} - \frac{1}{32} - \frac{1}{4} \right) = -\frac{5wl^4}{384};$$

$$y_{\max} = -\frac{5wl^4}{384EI} = -\frac{5Wl^3}{384EI}, \quad \text{Formula XIII.}$$

where $W = wl$, the total load.

If we substitute $x = l$ in the equation of the elastic line, we get $y = 0$, as the deflection at the right support. We might have used this condition, $y = 0$, when $x = l$, to determine C_1 .

PROBLEMS.

1. What is the deflection at the middle of a 2-inch by 12-inch floor joist, 15 feet between supports, due to a distributed load of 90 pounds per foot, if E is 1,350,000? Ans. 0.264 inch.

2. A 15-inch 42-pound I-beam is used with a span of 20 feet to carry a load of 800 pounds per foot. If E is 29,000,000, what is the deflection? What is the maximum fiber stress?

Ans. { Deflection at the middle, 0.225 inch;
Bending stress, 8150 pounds per square inch.

3. In Problem 1 what is the slope of the tangent to the beam at the supports? If the beam extends 4 feet beyond one support, how much is this extension elevated at the end when the load is applied between the supports?

4. If E is 29,000,000 for structural steel, what is the greatest deflection in a beam of length l between supports and depth d , if the load is uniformly distributed and the allowable fiber stress is 15,000 pounds per square inch? Apply result to a 12-inch beam of 20-foot span. Ans. 0.517 inch.

63. Beam Supported at the Ends with a Concentrated Load at the Middle. — With a beam supported at the ends, with a

load P at the middle, the end reactions are each $\frac{P}{2}$, and the moment from the left support to the load at the middle is $\frac{Px}{2}$.

This moment is positive, the left portion at any section tending

to turn the right portion clockwise. (The beam is *concave* upward.)

$$EI \frac{d^2y}{dx^2} = \frac{Px}{2}. \quad (1)$$

$$EI \frac{dy}{dx} = \frac{Px^2}{4} + C_1. \quad (2)$$

At the middle, from the symmetry of the sides, $\frac{dy}{dx} = 0$;

$$C_1 = -\frac{Pl^2}{16}. \quad (3)$$

$$EI \frac{dy}{dx} = \frac{Px^2}{4} - \frac{Pl^2}{16}. \quad (4)$$

$$EIy = \frac{Px^3}{12} - \frac{Pl^2x}{16} + C_2. \quad (5)$$

At the left support, where $x = 0$, $y = 0$;

$$C_2 = 0; \quad (6)$$

$$EIy = \frac{Px^3}{12} - \frac{Pl^2x}{16}. \quad (7)$$

At the middle, where $x = \frac{l}{2}$,

$$y_{\max} = \frac{Pl^3}{96 EI} - \frac{Pl^3}{32 EI} = -\frac{Pl^3}{48 EI}. \quad \text{Formula XIV.}$$

Formula XIV might be obtained from the cantilever with a load on the end. A beam supported at the ends with a load at the middle is equivalent to two cantilevers of length $\frac{l}{2}$ each

with a load $\frac{P}{2}$ at the end, the load pushing up instead of down.

Substituting $\frac{P}{2}$ and $\frac{l}{2}$ for P and l in Formula XI, we get Formula XIV.

Formula XIV is much used to determine the modulus of elasticity. Cantilevers are not suitable for accurate tests, as it is difficult to so fix a beam at one end that the tangent will not change slightly when the moment is applied. It is easy to place a beam on two supports and measure the *additional* deflection when a load is applied at the middle.

PROBLEMS.

1. A selected beam of red oak, 1.75 inches wide and 1.25 inches deep, was placed on two supports 12 inches apart and a load applied at the middle. When an addition of 607 pounds was made to the load the deflection at the middle was increased 0.050 inch. Find E .

Ans. 1,534,000 pounds per square inch.

2. In the beam of Problem 1 an addition of 721 pounds produced a deflection of 0.059 inch. Find E .

3. In Problem 1 how much would the last significant figures of the value of E be changed if the deflection readings were incorrect 0.0005 inch? if the breadth were incorrect 0.005 inch? if the depth were incorrect 0.005 inch? if the load were incorrect 1 pound? How much would E be changed if all these errors occurred at once in the same direction?

Ans. An error of 0.005 inch in the depth would change the result 1.2 per cent, a change of 18 in the significant figures.

4. The beam of Problem 1 broke under a load of 2315 pounds. Find the fiber stress at rupture.

> 5. What is the deflection at the middle of a 10-inch 25-pound I-beam of 15 feet span due to a load of 6000 pounds at the middle, if E is 29,000,000?

6. If a rod 5 feet long is clamped to one end of the beam of Problem 5, how much will the free end of this rod be elevated when the load is applied to the beam?

Ans. 0.206 inch.

> 7. What is the deflection at the middle of a 12-inch 31.5-pound I-beam of 20 feet span due to a distributed load of 360 pounds per foot and a load of 5000 pounds at the middle, if E is 29,000,000? What is the maximum fiber stress due to these loads?

Ans. Deflection at the middle, 0.437 inch.

> 8. Substitute $x = l$ in equation (7). The result is not the deflection at the right support. Why?

> 64. **Beam Supported at the Ends, Load at any Point between Supports.** — In the case of a beam with a concentrated load, the moment expression changes when we pass this load. The differential equation (1) and the equation of the elastic line (7) of the preceding article apply from the left support to the middle. Fortunately, on account of the symmetry of the two ends we could assume that the beam was horizontal under the load and thus have two conditions from which to determine the two arbitrary constants. When the load is not at the middle, $\frac{dy}{dx}$ is zero

for some point between the load and the middle. We must write the differential equation for both sides of the load. The solution of these *two* differential equations gives *four* arbitrary constants.

Fig. 94 represents a beam supported at the ends with a load P at a distance kl from the left support, which is taken as the origin. The letter k represents any fraction between zero and unity, and

is constant for any particular problem. The left reaction is $(1 - k)P$ and the right reaction is kP . From the left support to the load the moment is

$$P(1 - k)x;$$

and from the load to the right end it is

$$P(1 - k)x - P(x - kl).$$

It is convenient to write the differential equations for both portions of the beam and carry the integrations through together; remembering that the one set of equations applies from $x = 0$ to $x = kl$, *inclusive*, and the other set applies from $x = kl$ to $x = l$, *inclusive*.

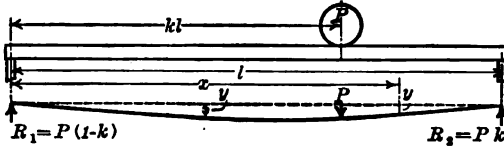

Fig. 94. — Supports at Ends, Load at any Point.

For all points from $x = 0$ to $x = kl$, inclusive,

$$EI \frac{d^2y}{dx^2} = P(1 - k)x; \quad (1)$$

$$EI \frac{dy}{dx} = \frac{P(1 - k)x^2}{2} + C_1. \quad (3)$$

For all points from $x = kl$ to $x = l$, inclusive,

$$EI \frac{d^2y}{dx^2} = P(1 - k)x - P(x - kl); \quad (2)$$

$$EI \frac{dy}{dx} = \frac{P(1 - k)x^2}{2} - \frac{P(x - kl)^2}{2} + C_2. \quad (4)$$

The curve of the beam is continuous under the load with no sudden change of direction, and $\frac{dy}{dx}$ from the left equation (3) is the same as $\frac{dy}{dx}$ from the right equation (4) at the common point $x = kl$. Accordingly, when $x = kl$, the second members of equations (3) and (4) are equal.

Equating these second members, we observe that the first terms of the two expressions are the same when $x = kl$, and that the second term of (4) vanishes:

$$C_1 = C_2.$$

Integrating again, remembering that $C_1 = C_2$:

$$EIy = \frac{P(1-k)x^3}{6} + C_1x + C_2. \quad (5) \quad \left| \quad EIy = \frac{P(1-k)x^3}{6} - \frac{P(x-kl)^3}{6} \right.$$

$$\text{When } x = 0, y = 0, \text{ hence} \quad \left. \begin{array}{l} + C_1x + C_4. \quad (6) \\ C_2 = 0. \end{array} \right.$$

When $x = kl$ the values of y for (5) and (6) are the same and the second members of these equations are equal; from which:

$$0 = C_2 = C_4.$$

$$\left. \begin{array}{l} \text{Substituting the value of } C_1 \\ \text{from (7) in (5), we get:} \\ EIy = \frac{P}{6}(1-k)x^3 \\ + \frac{P}{6}\left\{(1-k)^3 - (1-k)\right\}l^2x. \quad (8) \end{array} \right| \quad \begin{array}{l} \text{When } x = l \text{ in (6), } y = 0; \\ C_1 = \frac{Pl^2}{6}\left\{(1-k)^3 - (1-k)\right\}. \quad (7) \end{array}$$

As a check, apply equation (8) to find the deflection under the load when the load is at the middle; $k = \frac{1}{2}$; $(1-k) = \frac{1}{2}$; $x = \frac{l}{2}$;

$$EIy = \frac{P}{6} \cdot \frac{l^3}{16} + \frac{P}{6} \left(\frac{1}{8} - \frac{1}{2} \right) \frac{l^3}{2} = -\frac{Pl^3}{48}. \quad (\text{Compare Formula XIV.})$$

The point of maximum deflection is given by

$$3x^2 = (1 - (1-k)^2)l^2,$$

provided that $k > \frac{1}{2}$ so that equation (3) for the left side applies.

It may be shown that $\frac{l}{2} < x < kl$, where x is the position of maximum deflection and $k > \frac{1}{2}$; and consequently the point of maximum deflection lies between the load and the middle of the beam.

In finding the point of maximum deflection and the deflection at this point, it is convenient to use the simpler equations to the left of the load (3) and (8). In case the load is to the left of the middle, imagine yourself on the opposite side of the beam. This will make k greater than one-half.

PROBLEMS.

1. If $k = 0.6$, what is the point of maximum deflection? *Ans.* $0.529 l$.
2. Show that the point of maximum deflection is never beyond $\frac{l}{\sqrt{3}}$.
3. A 3-inch by 2-inch beam 10 feet long supports a load of 45 pounds 6 feet from the left end. If the beam is supported at the ends, and E is 1,500,000, find the deflection at the middle, under the load, and the maximum deflection.
Ans. At middle, 0.510 inch; under load, 0.498 inch.

9

65. **Beam Supported at Ends, Two Equal Loads Symmetrically Placed.** — An important case is that of a beam supported at two points with two equal loads at equal distances from the supports. If we neglect the weight of the beam, the shear is zero and the moment is constant between the loads. For this reason this method of loading is much used in tests of beams, for it enables the experimenter to study the effect of moment independent of shear between the loads, and the effect of shear and moment combined beyond the loads. The moment and the resulting stress in any horizontal fiber being constant between the loads, measurements of elongation enable him to locate the neutral axis.

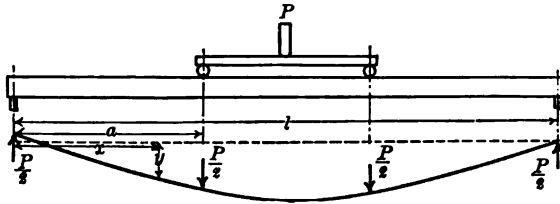

Fig. 95. — Supports at Ends, Two Loads Symmetrically Placed.

In Fig. 95, the load at each point is represented by $\frac{P}{2}$. The total span is l and the loads are at a distance a from the supports. As usual, the left support is taken as the origin. There are three moment equations. Owing to the symmetry, we see that $\frac{dy}{dx}$ is zero at the middle. If we write the equations for the left portion and for that between the loads, we shall need four conditions to determine the constants. These are $y = 0$ when $x = 0$ in the first portion; $\frac{dy}{dx}$ has the same value for both equations under the first load; y has the same value for both equations under this load; and $\frac{dy}{dx} = 0$ at the middle.

Writing the equations as in the preceding article:

<p>From $x = 0$ to $x = a$,</p> $EI \frac{d^2y}{dx^2} = \frac{Px}{2} \quad (1)$		<p>From $x = a$ to $x = (l - a)$,</p> $EI \frac{d^2y}{dx^2} = \frac{Pa}{2} \quad (2)$
---	--	---

$EI \frac{dy}{dx} = \frac{Px^2}{4} + C_1 \quad (3)$		$EI \frac{dy}{dx} = \frac{Pax}{2} + C_3 \quad (4)$
---	--	--

$$\frac{Pa^2}{4} + C_1 = \frac{Pa^2}{2} + C_3;$$

$$C_1 = \frac{Pa^2}{4} + C_3.$$

	<p>When $x = \frac{l}{2}$, $\frac{dy}{dx} = 0$;</p>
--	---

	$C_3 = -\frac{Pal}{4}.$
--	-------------------------

$$C_1 = \frac{Pa^2}{4} - \frac{Pal}{4}.$$

$$EI \frac{dy}{dx} = \frac{Px^2}{4} + \frac{Pa^2}{4} - \frac{Pal}{4}.$$

	$EI \frac{dy}{dx} = \frac{Pax}{2} - \frac{Pal}{4}.$
--	---

$$EIy = \frac{Px^3}{12} + \frac{Pa^2x}{4} - \frac{Palx}{4} + C_2 \quad (5)$$

	$EIy = \frac{Pax^2}{4} - \frac{Palx}{4} + C_4 \quad (6)$
--	--

$$C_2 = 0.$$

$$\frac{Pa^3}{12} + \frac{Pa^3}{4} - \frac{Pa^2l}{4} = \frac{Pa^3}{4} - \frac{Pa^2l}{4} + C_4;$$

$$EIy = \frac{Px^3}{12} + \frac{Pa^2x}{4} - \frac{Palx}{4} \quad (7)$$

	$C_4 = \frac{Pa^3}{12}.$
	$EIy = \frac{Pax^2}{4} - \frac{Palx}{4} + \frac{Pa^3}{12} \quad (8)$

	<p>At the middle, where $x = \frac{l}{2}$,</p>
--	---

	$y_{\max} = \frac{Pa}{EI} \left(\frac{a^2}{12} - \frac{l^2}{16} \right) \quad (9)$
--	---

We will check (9) for the case when $a = \frac{l}{2}$,

$$y_{\max} = \frac{Pl}{EI} \left(\frac{l^2}{96} - \frac{l^2}{32} \right) = -\frac{Pl^3}{48EI}.$$

If the loads are placed at the third points, the deflection at the middle is

$$y_{\max} = -\frac{23Pl^3}{1296EI}.$$

PROBLEMS.

1. If a is equal to one-fourth of the length between supports, find the maximum deflection.

2. A 6-inch by 8-inch wooden beam supported at points 12 feet apart is loaded with two equal loads of 800 pounds each 4 feet from the supports. If E is 1,200,000, what is the deflection under a load and at the middle?

Ans. Under a load, 0.240 inch; at middle, 0.276 inch.

3. In Problem 2, two vertical lines are ruled on one side of the beam 20 inches on the right and left of the middle. When the load is applied, what angles will these lines make with each other?

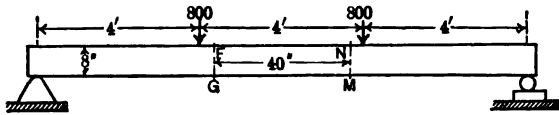

Fig. 96.

4. In Problem 3, Fig. 96, the distance FN between the upper ends of the lines is measured with a delicate extensometer. How much is this distance diminished when the loads are applied, and what is the unit deformation in 40 inches?

Ans. Total, 0.0200 inch; unit 0.00050 inch.

5. Compute the fiber stress in the upper fibers from the unit deformation in Problem 4 and check by Formula VIII.

6. Show that the error due to measuring the chord instead of the arc in Problem 4 is less than 0.00004 inch, and that the relative error in the unit deformation is less than one part in 500. (Use the first two terms of the sine series for the half-angle.)

66. **Any Beam with Two Supports.** — All the cases of deflections so far considered are cases of two supports. (In the cantilever one of these supports pushes *down* in the wall.) In all problems of this sort, the reactions may be computed algebraically and the moment equations written for any section. At each support and at each concentrated load the equation of moment changes and a different differential equation must be

formed. The solution of each differential equation of the second order involves two integration constants which must be determined from the values of y and $\frac{dy}{dx}$ at points to which the equations apply. There must be twice as many of these known conditions as there are differential equations.

PROBLEMS.

1. A beam of length $l + a$, uniformly loaded w pounds per unit length, is supported at the left end and at a distance a from the right end.

Can you get the equation of the elastic line of the portion between the supports without getting the equation of the length a to the right of the right support? Why? Can you get the equation of the elastic line for the portion beyond the right support without writing the differential equation for the portion between the supports? Why?

2. A 6-inch by 6-inch wooden beam 15 feet long is supported at the left end and 5 feet from the right end and carries a distributed load, including its own weight, of 60 pounds per foot. The modulus of elasticity is 1,000,000.

Draw the shear diagram, 1 inch equals 100 pounds. Draw the moment diagram, 1 inch equals 200 foot pounds. Draw the deflection diagram, 1 inch equals 0.1 inch deflection. Find the point of zero moment from the moment equation and check from the shear diagram.

3. A beam of length $l + a$ is supported at a distance a from the right end and is held down at the right end. Find the equation of the elastic line when a load P is applied at the left end, neglecting the weight of the beam. How does this differ from a cantilever with a load on the end?

4. A 10-inch 25-pound I-beam 20 feet long is supported 3 feet from the left end and 5 feet from the right end. What is the maximum allowable load, including its own weight, which may be uniformly distributed over the entire length, if the allowable fiber stress is 12,000 pounds per square inch? What is the deflection at the middle, the maximum deflection between the supports, and the deflection at the right end? *Ans.* Load, 1952 pounds per foot.

67. Stiffness of Beams. — The stiffness of a beam is the reciprocal of the deflection. The stiffness of a beam may be defined as the load which will produce unit deflection. We are not accustomed to express stiffness in this way, but use it as a relative term.

In the expression for the maximum deflection of all the beams which we have considered, the terms E and I occur in the denominator. The stiffness of a beam varies directly as the modulus of elasticity and directly as the moment of inertia of its cross section. The moment of inertia of a rectangular section varies as the cube of the depth, consequently the stiffness of a rectangular section varies in the same ratio.

All the expressions for the maximum deflection contained the cube of the length in the numerator. The stiffness of beams of the same cross section varies inversely as the cube of their length.

PROBLEMS.

1. How does the stiffness of a 4-inch by 6-inch beam compare with that of a 4-inch by 4-inch beam of the same material?
2. How does the stiffness of a 4-inch by 6-inch beam with the 6-inch side vertical compare with that of the same beam with the 4-inch side vertical?
3. How does the stiffness of a 2-inch by 12-inch beam 15 feet long compare with that of a 2-inch by 8-inch beam 10 feet long? Which is the stronger?

Lewis P. McGilvary
Elect. Eng. 1916

CHAPTER VIII.

BEAMS WITH MORE THAN TWO SUPPORTS.

68. **Relation of Deflection to Stress.**— In the case of beams with *two* supports, including cantilevers, we are able to compute the moment and consequently the fiber stress without making use of the deflection. From this, since unit stresses are more important from the engineering standpoint than deflections, the student may get the impression that we are giving too much attention to the elastic curve. However, when we attempt to get the stress in a beam with more than two supports, we find that we must write the differential equations and solve for the elastic curve before we can get even the reactions. (In some cases it is only necessary to integrate once for the slope of the curve and determine the constants.) Consequently, a knowledge of these equations of deflection is indispensable for the calculation of *stresses* except in the simplest cases.

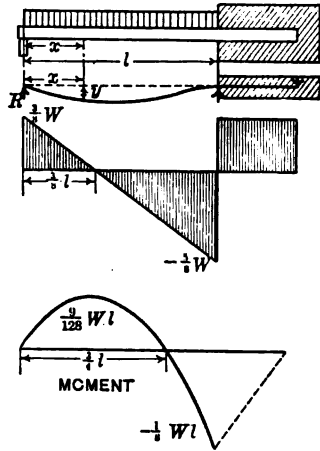

Fig. 97. — Beam Fixed at One End and Supported at the Other.

69. **Cantilever Supported at One End.**— Fig. 97 represents a cantilever fixed at the right end and supported at the left end, and carrying a uniformly distributed load of w pounds per unit length. The origin is taken at the left support. The moment at a section at a distance x from the origin is:

$$M = R_1x - \frac{wx^2}{2}$$

The reaction at the left support, R_1 , is at present unknown. We will use it in the differential equations and determine its value later.

$$EI \frac{d^2y}{dx^2} = R_1x - \frac{wx^2}{2} \tag{1}$$

$$EI \frac{dy}{dx} = \frac{R_1x^2}{2} - \frac{wx^3}{6} + C_1 \tag{2}$$

When $x = l$, $\frac{dy}{dx} = 0$, hence $C_1 = \frac{wl^3}{6} - \frac{R_1 l^2}{2}$; (3)

$$EI \frac{dy}{dx} = \frac{R_1 x^2}{2} - \frac{R_1 l^2}{2} - \frac{wx^3}{6} + \frac{wl^3}{6}. \quad (4)$$

$$EI y = \frac{R_1 x^3}{6} - \frac{R_1 l^2 x}{2} - \frac{wx^4}{24} + \frac{wl^3 x}{6} + C_2. \quad (5)$$

When $x = 0$, $y = 0$, hence $C_2 = 0$.

We still have one condition from which to find the reaction R_1 :
When $x = l$, $y = 0$, which, substituted in equation (5), gives

$$R_1 = \frac{3wl}{8} = \frac{3W}{8}, \quad (6)$$

where W is the total distributed load.

$$y = -\frac{w}{48EI} (2x^4 - 3lx^3 + l^3x). \quad (7)$$

With R_1 known we may now write the moment equation

$$M = \frac{3Wx}{8} - \frac{wx^2}{2}. \quad (8)$$

PROBLEMS.

1. Draw shear and moment diagrams for beam fixed at one end and supported at the other. Find the moment at each dangerous section from the shear diagram and compare with the result from the equation of moments.

Ans. Moment at dangerous sections, $\frac{9Wl}{128}$, $-\frac{Wl}{8}$.

2. How does the greatest moment, numerically, compare with that of a beam supported at the ends?

3. Find the position of maximum deflection and the value of this maximum deflection.

Ans. Point of maximum deflection is $0.4215l$ from the left support.

Substituting the value of R in equation (4), or differentiating (7), we get for the points where the beam is horizontal:

$$8x^3 - 9lx^2 + l^3 = 0.$$

Since the beam is horizontal at the wall, $x = l$ must satisfy this cubic equation. Dividing by the corresponding factor, $x - l$, we get a quadratic. Explain the meaning of the negative root.

BEAMS WITH MORE THAN TWO SUPPORTS 121

4. A 4-inch by 6-inch wooden beam 20 feet long is supported at both ends and at the middle and carries a uniformly distributed load, including its own weight, of 120 pounds per foot. What is the maximum fiber stress? Where is it? What is the load on each of the three supports? Would the beam be stronger or weaker if it were cut in two at the middle and simply rested on the middle support instead of being continuous over it?

5. Draw the shear and moment diagrams for Problem 4: 1 inch equals 4 feet length, 200 pounds shear, and 1000 foot-pounds moment. In deriving the theory of this article, we assume that the beam is absolutely fixed at one end; that the tangent remains horizontal when the load is applied. If it is not perfectly fixed, as in the case of a beam clamped at one end, the reaction at the supported end will be greater than that given by the theory. We also assume that the support suffers no displacement when the load is applied. Neither of these conditions is fully met in the arrangement of Fig. 97. Fig. 98

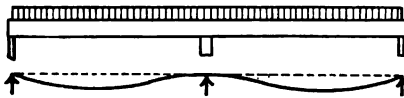

Fig. 98. — Continuous Beam of Two Equal Spans.

shows a beam with supports at the ends and at the middle. If these supports are so dimensioned that a load of 10 pounds at the middle will produce the same deformation as a load of 3 pounds at either of the others, a uniform load over the length will leave the tangent horizontal over the middle support, and the ends will not be deflected with reference to the middle. Either half of this beam will now fulfill the conditions of the theory.

6. A 6-inch by 8-inch wooden beam is supported at the middle and 15 feet on each side of the middle and carries a load of 150 pounds per foot for this 30 feet of length. The end posts are 6 inches by 6 inches and rest on concrete footings 1 foot square. What should be the dimensions of the footing for the middle post if the settlement of all shall be equal?

7. In Problem 6 suppose that the middle post settles 0.1 inch and that E equals 1,200,000. Find the reaction on each support.

8. A beam is absolutely fixed at one end and is supported at the other by a support which is deformed a unit distance by a load Q . What is the reaction at this support due to a uniform load W over the entire beam?

$$\text{Ans. } R_1 = \frac{\frac{Wl^3}{8}}{\frac{l^3}{3} + \frac{EI}{Q}}$$

70. Cantilever Supported at One End, Load Concentrated. —

Fig. 99 represents a beam supported at the left end and fixed at the right end, with a load P at a distance kl from the left support. We will carry the two sets of equations together as in Article 64.

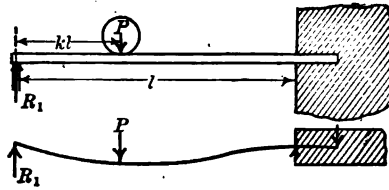

Fig. 99.

From left end to load,

$$EI \frac{d^2y}{dx^2} = R_1x. \quad (1)$$

$$EI \frac{dy}{dx} = \frac{R_1x^2}{2} + C_1. \quad (3)$$

From load to wall,

$$EI \frac{d^2y}{dx^2} = R_1x - P(x - kl). \quad (2)$$

$$EI \frac{dy}{dx} = \frac{R_1x^2}{2} - \frac{P(x - kl)^2}{2} + C_3. \quad (4)$$

When $x = kl$ the curves have a common tangent, from which

$$C_1 = C_3. \quad (5)$$

When $x = l$, the tangent is horizontal,

$$R_1l^2 - P(1 - k)^2l^2 + 2C_3 = 0. \quad (6)$$

We will not substitute the value of C_3 in equations (3) and (4) at present.

$$EIy = \frac{R_1x^3}{6} + C_3x + C_2. \quad (7)$$

$$EIy = \frac{R_1x^3}{6} - \frac{P(x - kl)^3}{6} + C_3x + C_4. \quad (8)$$

When $x = 0$, $y = 0$, $C_2 = 0$.

When $x = kl$, y is the same for both curves,

$$0 = C_2 = C_4 = 0.$$

When $x = l$, $y = 0$.

$$R_1l^2 - P(1 - k)^3l^2 + 6C_3 = 0. \quad (9)$$

Combining (6) and (9), we get:

$$R_1 = \frac{P}{2} \{ 3(1 - k)^2 - (1 - k)^3 \}. \quad (10)$$

PROBLEMS.

1. If $k = \frac{1}{2}$, show that the end reaction is $\frac{1}{8}P$.

2. If $k = \frac{1}{2}$, find the moment at each dangerous section and the location of the point of *inflection* where the moment changes sign.

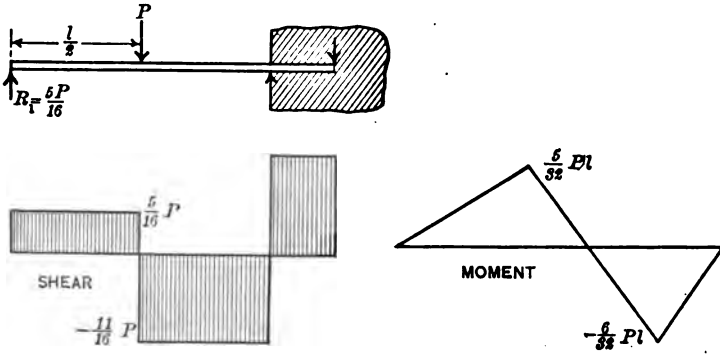

Fig. 100. — Beam Fixed at One End and Supported at the Other with Load at the Middle.

3. A 2-inch by 1-inch wooden beam is securely clamped so that 8 feet projects as a cantilever. The end of this cantilever rests on a platform scale. When a load of 20 pounds is applied 3 feet from the supported end, how much should be the increase in the scale reading? *Ans.* 9.28 pounds.

71. General Equations of Moment and Shear. — If we attempt to derive the equations for a beam *fixed* at the *left* end and supported at the right end, we have difficulty in forming the expression for the moment. It is therefore advisable to derive a general equation which applies to all cases. In Article 47, we have this expression for moment:

$$M = R(c + x) - Q(b + x) - \sum P(x - a) - \frac{wx^2}{2}; \quad (1)$$

$$M = Rc - Qb + (R - Q)x - \sum P(x - a) - \frac{wx^2}{2}. \quad (2)$$

Now the term $Rc - Qb$ represents the moment at the origin of all the forces on the left of the origin. $R - Q$ is the sum of the vertical forces to the left of the origin. Equation (2) may be written:

$$M = M_0 + S_0x - \sum P(x - a) - \frac{wx^2}{2}, \quad \text{Formula XV.} \quad (3)$$

where

M is the moment at any section at a distance x from the origin;

M_0 is the moment *at* the origin;

S_0 is the vertical shear at the origin;

$\Sigma P(x - a)$ is the sum of the moments of all the concentrated forces between the origin and the section;

$\frac{wx^2}{2}$ is the moment of the distributed forces between the origin and the section.

PROBLEMS.

1. A beam 20 feet long is supported at the right end and 5 feet from the left end and carries a load, including its own weight, of 120 pounds per foot and a load of 2800 pounds 17 feet from the left end. Calculate the moment at the left support and write the moment equation for the portion between the supports, using a point infinitely near the left support as the origin of coordinates.

Ans. $M = -1500 + 1560x - 60x^2$, from $x = 0$ to $x = 12$ feet.

$M = -1500 + 1560x - 60x^2 - 2800(x - 12)$, from $x = 12$ feet to $x = 15$ feet.

2. Form the derivatives of the moment equations above and solve for the position of maximum moment. Neither gives the correct result. Why? What is the meaning of the results obtained?

3. Solve the moment equations above for the positions of zero moment.

Ans. 1 foot and 15 feet.

Each of these quadratic equations has two solutions. How do you know which one to use?

72. **Point of Inflection.** — A point of inflection in a beam is a point where the moment changes sign, and where the center of curvature changes from one side of the beam to the other. A point of inflection is also called a point of counterflexure. From our calculus we remember that a point of inflection occurs when $\frac{d^2y}{dx^2}$ equals zero, provided $\frac{d^3y}{dx^3}$ does not equal zero at the point.

In the case of an elastic curve,

$$\frac{d^2y}{dx^2} = \frac{M}{EI}, \quad \frac{d^3y}{dx^3} = \frac{S}{EI}.$$

EI being always positive, a point of inflection occurs where the moment is zero and the shear is not zero. In Problem 3 of the preceding article, the first answer gives a point of counterflexure. At this point the moment is zero and the beam could be cut in two and one portion support the other by means of slight projection to take the shearing stress.

Fig. 101 represents the beam of Problems 1 and 3 of Article 71. The left portion weighing 720 pounds supports the right portion

weighing 1680 pounds and the load of 2800 pounds. In the upper figures we have drawn the beam as made of two parts united by a pin connection at the point of inflection. In the

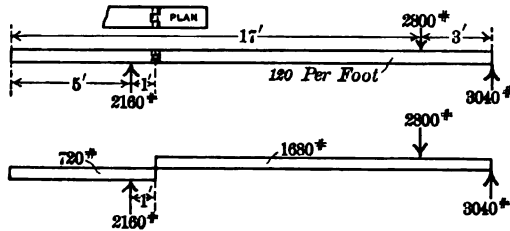

Fig. 101. — Point of Counterflexure.

lower figure the beam is represented as cut at this point with one end resting on the other. To find the force with which the left portion lifts the right portion, take moments around the left support. The 720 pounds with center of gravity 2 feet to the left of the support balances 1440 pounds 1 foot to the right of the support. Taking moments about the right support:

$$\begin{aligned} 2800 \times 3 &= 8,400 \\ 1680 \times 7 &= 11,760 \\ \hline S \times 14 &= 20,160 \\ S &= 1,440 \end{aligned}$$

If we examine the shear diagram, we find the shear at this point is 1440 pounds.

PROBLEMS.

- 1. A beam of length l with uniform load of w pounds per foot is supported one-fourth the length from the left end and one-fifth the length from the right end. Find the points of counterflexure.
- 2. From the shear diagram of Article 69 determine the point of inflection of a beam fixed at one end and supported at the other.
- 73. **Cantilever Fixed at Left End, Supported at Right End, Load Uniformly Distributed.** — Having now the general equation of moment (Formula XV), we may take the case of a beam fixed at the *left end*. With a uniform load only

$$EI \frac{d^2y}{dx^2} = M_0 + S_0x - \frac{wx^2}{2}. \tag{1}$$

$$EI \frac{dy}{dx} = M_0x + \frac{S_0x^2}{2} - \frac{wx^3}{6} + [C_1 = 0]. \tag{2}$$

$$EIy = \frac{M_0x^2}{2} + \frac{S_0x^3}{6} - \frac{wx^4}{24} + [C_2 = 0]. \tag{3}$$

These equations so far apply to *any beam fixed at the left end with a uniform load*. Applying the results to a beam supported at the right end:

$$0 = 12 M_0 + 4 S_0 l - wl^2. \quad (4)$$

We have used our three conditions for determining constants and still need another to be used with (4) to determine M_0 and S_0 . The moment at the right support where $x = l$ is 0. Substituting in the moment equation:

$$0 = M_0 + S_0 l - \frac{wl^2}{2}. \quad (5)$$

Combining (5) and (4), we get:

$$M_0 = -\frac{wl^2}{8} = -\frac{Wl}{8},$$

$$S_0 = \frac{5wl}{8} = \frac{5W}{8},$$

$$y = -\frac{w}{48EI} (2x^4 - 5lx^3 + 3l^2x^2). \quad (6)$$

PROBLEMS.

1. Substitute $l - x$ for x in equation (6) and compare result with equation (7) of Article 69.
2. Find the position of maximum deflection and compare with Article 69, Problem 3.
3. Draw shear and moment diagrams and compare with Fig. 97.
4. How does the maximum deflection in a beam of this kind compare with that of a beam supported at the ends? *Ans.* 41.6 per cent as much.

> 74. Beam Fixed at Both Ends, Uniformly Loaded. —

$$EI \frac{d^2y}{dx^2} = M_0 + S_0 x - \frac{wx^2}{2}. \quad (1)$$

$$EI \frac{dy}{dx} = M_0 x + \frac{S_0 x^2}{2} - \frac{wx^3}{6} + [C_1 = 0]. \quad (2)$$

$$0 = 6 M_0 + 3 S_0 l - wl^2. \quad (3)$$

$$EI y = \frac{M_0 x^2}{2} + \frac{S_0 x^3}{6} - \frac{wx^4}{24} + [C_2 = 0]. \quad (4)$$

$$0 = 12 M_0 + 4 S_0 l - wl^2; \quad (5)$$

$$S_0 = \frac{wl}{2} = \frac{W}{2};$$

$$M_0 = -\frac{wl^2}{12} = -\frac{Wl}{12}.$$

$$y = -\frac{wx^2}{24EI} (l - x)^2. \quad (6)$$

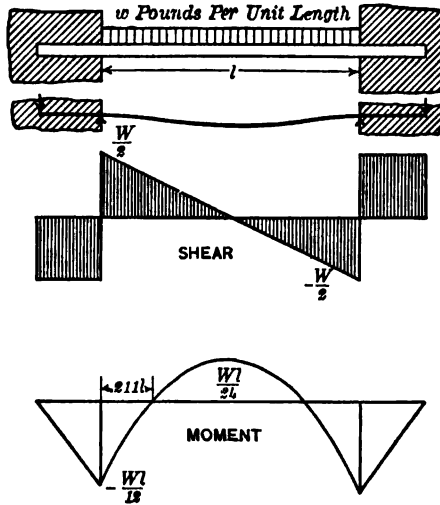

Fig. 102.

PROBLEMS.

1. Show that the moment at the middle is one-half that at the ends.
2. Find the points of inflection. *Ans.* $0.211 l$ and $0.789 l$.
3. What is the maximum deflection at the middle? *Ans.* $-\frac{Wl^3}{384 EI}$.

75. Beam Fixed at Both Ends, Concentrated Load kl from Left End. —

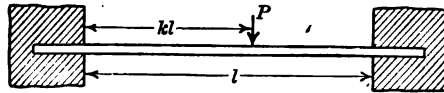

Fig. 103.

From left end to load,

$$EI \frac{d^2y}{dx^2} = M_0 + S_0x. \quad (1)$$

$$EI \frac{dy}{dx} = M_0x + \frac{S_0x^2}{2} + [C_1 = 0]. \quad (3)$$

$$EIy = \frac{M_0x^2}{2} + \frac{S_0x^3}{6} + [C_2 = 0]. \quad (6)$$

From load to right end,

$$EI \frac{d^2y}{dx^2} = M_0 + S_0x - P(x-kl). \quad (2)$$

$$EI \frac{dy}{dx} = M_0x + \frac{S_0x^2}{2} - \frac{P(x-kl)^2}{2} + [C_3 = 0]. \quad (4)$$

$$0 = 2M_0 + S_0l - P(1-k)^2. \quad (5)$$

$$EIy = \frac{M_0x^2}{2} + \frac{S_0x^3}{6} - \frac{P(x-kl)^3}{6} + [C_4 = 0]. \quad (7)$$

$$0 = 3M_0 + S_0l - P(1-k)^3. \quad (8)$$

From (5) and (8):

$$S_0 = P \{3(1 - k)^2 - 2(1 - k)^3\};$$

$$M_0 = -Pl \{(1 - k)^2 - (1 - k)^3\}.$$

PROBLEMS.

1. Construct the moment and shear diagrams when $k = \frac{1}{2}$.
2. When $k = \frac{1}{2}$ show that the deflection at the middle is one-fourth as great as it is in a beam simply supported at the ends with a load at the middle and that the unit stress is one-half as great.
3. Show that the beam cut off as in Fig. 104 has the same shear at walls, moment at the middle, deflection at the middle and quarter points, as the beam in Fig. 103.

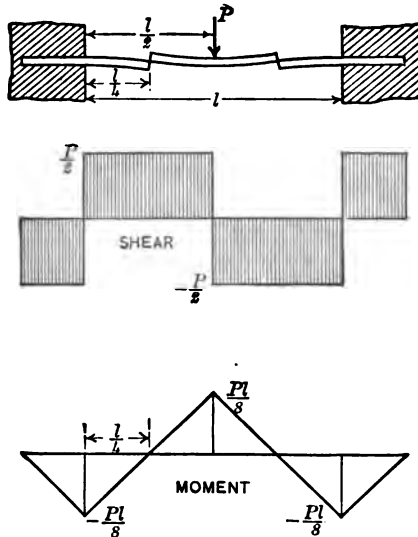

Fig. 104. — Points of Counterflexure in Beam with Ends Fixed.

76. Theorem of Three Moments. — The methods of the preceding articles may be applied to any number of spans or to any number of concentrated loads. However, when it becomes necessary to write more than two moment equations and solve for the corresponding constants, the work becomes laborious. When, as is usually the case, it is desired to find the moments,

reactions, and shears, without getting the deflections, the *theorem of three moments* is of great use.

The theorem of three moments is an *algebraic equation* which expresses the relation of the moments at three successive supports of a continuous beam in terms of the length of the intervening spans and the loads which they carry. In Fig. 105, the moments over the supports are represented by M_a , M_b , M_c . The length of the span from support A to support B is l_1 , and from B to C it is l_2 . Fig. 105 represents a uniformly distributed load of w_1 pounds per unit length for the first span and w_2 pounds per unit length for the second span. The subscripts a , b , c , represent the *order* from left to right and may be applied to *any three points in succession*. The same is true of the subscripts 1 and 2 applied to the spans and the unit loads.

We will take the origin of coördinates for the first span at A and for the second span at B and write a differential equation for each span, remembering that the origin is different for the two equations.

77. Theorem of Three Moments for Distributed Loads. —

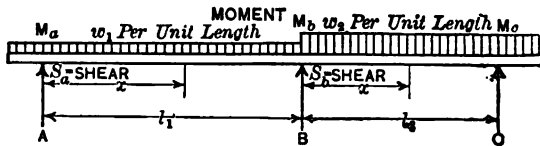

Fig. 105.

<p style="text-align: center;"><i>Span AB.</i></p> $EI \frac{d^2y}{dx^2} = M_a + S_a x - \frac{w_1 x^2}{2}.$ $EI \frac{dy}{dx} = M_a x + \frac{S_a x^2}{2} - \frac{w_1 x^3}{6} + C_1.$ <p>At support B, $x = l_1$,</p>	<p style="text-align: center;"><i>Span BC.</i></p> $EI \frac{d^2y}{dx^2} = M_b + S_b x - \frac{w_2 x^2}{2}. \quad (1)$ $EI \frac{dy}{dx} = M_b x + \frac{S_b x^2}{2} - \frac{w_2 x^3}{6} + C_3. \quad (2)$ <p>At support B, $x = 0$,</p>
--	--

$$\frac{dy}{dx} = \frac{dy}{dx},$$

$$6 M_a l_1 + 3 S_a l_1^2 - w_1 l_1^3 + 6 C_1 = 6 C_3. \quad (3)$$

$$EIy = \frac{M_a x^2}{2} + \frac{S_a x^3}{6} - \frac{w_1 x^4}{24} + C_1 x + [C_2 = 0].$$

At right end of span,

$$0 = 12M_a l_1 + 4S_a l_1^2 - w_1 l_1^3 + 24C_1. \quad (4)$$

$$EIy = \frac{M_b x^2}{2} + \frac{S_b x^3}{6} - \frac{w_2 x^4}{24} + C_3 x + [C_4 = 0]. \quad (5)$$

At right end of span BC ,

$$0 = 12M_b l_2 + 4S_b l_2^2 - w_2 l_2^3 + 24C_3. \quad (6)$$

Combining equations (6), (5) and (3) to eliminate C_1 and C_3 :

$$12M_a l_1 + 12M_b l_2 + 8S_a l_1^2 + 4S_b l_2^2 - 3w_1 l_1^3 - w_2 l_2^3 = 0. \quad (7)$$

We wish to eliminate the shear and bring in the moment at C :

$$M = M_a + S_a x - \frac{w_1 x^2}{2};$$

When $x = l_1$,

$$M_b = M_a + S_a l_1 - \frac{w_1 l_1^2}{2};$$

$$S_a l_1 = M_b - M_a + \frac{w_1 l_1^2}{2}.$$

$$S_b l_2 = M_c - M_b + \frac{w_2 l_2^2}{2}. \quad (8)$$

Substituting these values of the shear in (7):

$$4M_a l_1 + 8M_b (l_1 + l_2) + 4M_c l_2 + w_1 l_1^3 + w_2 l_2^3 = 0; \quad (9)$$

$$M_a l_1 + 2M_b (l_1 + l_2) + M_c l_2 = -\frac{1}{2}(w_1 l_1^3 + w_2 l_2^3). \quad (10)$$

Equation (10) is called the theorem of three moments for distributed loads.

If the spans are equal and the loads per unit length in the two successive spans are the same, the equation of three moments becomes:

$$M_a + 4M_b + M_c = -\frac{wl^2}{2}. \quad \text{Formula XVI.}$$

78. Calculation of Moments. — The theorem of three moments applies to continuous beams with any number of supports. We first apply the theorem for three consecutive supports, beginning with the first one. We next write the equation beginning with the second support as A . This is continued till all the moments are used. If there are four supports, two equations are written; if there are five supports three equations are required. Since

there are always two more unknown moments than there are equations, we must know two of the moments or have some relations from which to find them. Let us take the case of a beam with four supports and three equal spans, each loaded w pounds per unit length. The simple form of the theorem (Formula XVI) applies.

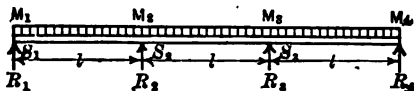

Fig. 106. — Uniformly Loaded Beam of Three Equal Spans.

This is represented by Fig. 106. Representing the moments by the subscripts 1, 2, 3, 4, as they refer now to definite moments and not merely to the order of arrangement, the equations are

$$M_1 + 4 M_2 + M_3 = -\frac{wl^2}{2}. \tag{1}$$

$$M_2 + 4 M_3 + M_4 = -\frac{wl^2}{2}. \tag{2}$$

If the beam does not overhang the end supports, $M_1 = 0$ and $M_4 = 0$. Solving the equations for this case we get

$$M_2 = M_3 = -\frac{wl^2}{10}.$$

PROBLEMS.

1. Find the moments for two equal spans, with uniform loads on both, with no overhang at the end supports.

Ans. $M_1 = 0, M_2 = -\frac{wl^2}{8}, M_3 = 0.$

2. Find the moments over the supports for four equal spans, with uniform loads on each and with no overhang.

Ans. $M_1 = 0, M_2 = -\frac{3wl^2}{28}, M_3 = -\frac{wl^2}{14}, M_4 = M_3, M_5 = 0.$

3. Find the moments over the supports with two equal spans of length l , and overhangs of $0.6l$ to the left of the left support and $0.4l$ to the right of the right support, with a uniformly distributed load throughout the entire length.

Ans. $M_1 = -0.18wl^2, M_2 = -0.06wl^2, M_3 = -0.08wl^2.$

4. A beam 30 feet long, weighing w pounds per foot, rests on four supports so as to make three equal spans of 8 feet each, and overhangs the left support 4 feet and the right support 2 feet. Find the moment over each support.

Ans. $-8w, -4.4w, -6.4w, -2w.$

5. A uniformly loaded beam rests on three supports so as to have two equal spans with equal overhang on each end. What must be the ratio of overhang to span if the moments at all supports are the same?

Ans. Overhang 0.408 of the length of span.

6. A beam 20 feet long with a uniformly distributed load is supported at the ends and 12 feet from the left end. What is the moment at the second support? *Ans.* — 14 w .

7. A shaft 30 feet long, weighing 10 pounds per foot, is supported by three bearings at 4 feet from the left end, 14 feet from the left end, and 4 feet from the right end. It carries a load of 200 pounds 1 foot from the left end, and a load of 300 pounds 2 feet from the right end. Find the moment at each bearing. *Ans.* — 680, 185, — 680 foot pounds.

79. **Calculation of Shear.** — To determine the shear to the right of any support, we make use of equation (8) of Article 77.

$$S_a = \frac{M_b - M_a}{l_1} + \frac{w_1 l_1}{2}. \quad \text{Formula XVII.}$$

S_a is the shear just to the right of *any* support;

M_a is the moment over that support;

M_b is the moment over the next support;

w_1 is the load per unit length between these supports.

Notice that the last term of the formula is simply half the load on the span.

We will apply this formula to the case of three equal spans and four supports considered in Article 78.

To find the shear at the right of the first support

$$S_1 = \frac{-\frac{wl^2}{10} - 0}{l} + \frac{wl}{2} = 0.4 wl = 0.4 W.$$

At the right of the second support,

$$S_2 = \frac{-\frac{wl^2}{10} + \frac{wl^2}{10}}{l} + \frac{wl}{2} = 0.5 wl = 0.5 W.$$

In the same way, $S_3 = 0.6 wl = 0.6 W$.

Fig. 107 gives the moments over the supports and the shears to the right of each support for the case of three equal spans.

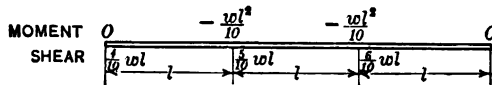

Fig. 107.

PROBLEMS.

1. Calculate the shear to the right of each support in Problem 2 of Article 78. *Ans.* $S_1 = \frac{11 wl}{28}$, $S_2 = \frac{15 wl}{28}$, $S_3 = \frac{13 wl}{28}$, $S_4 = \frac{17 wl}{28}$.

BEAMS WITH MORE THAN TWO SUPPORTS 133

2. Calculate the shear at the right of each support in Problem 3 of Article 78.
Ans. $0.62 wl$, $0.48 wl$.

The shear at the left of any support is obtained from the shear at the right of the preceding support by subtracting the intervening load, according to the definition of vertical shear. The shear at the left of the second support in Fig. 107 is $-0.6 wl$, at the left of the third support, $-0.5 wl$, and at the left of the fourth support, $-0.4 wl$.

The reaction at any support is computed by subtracting the shear at the left from the shear at the right of the support.

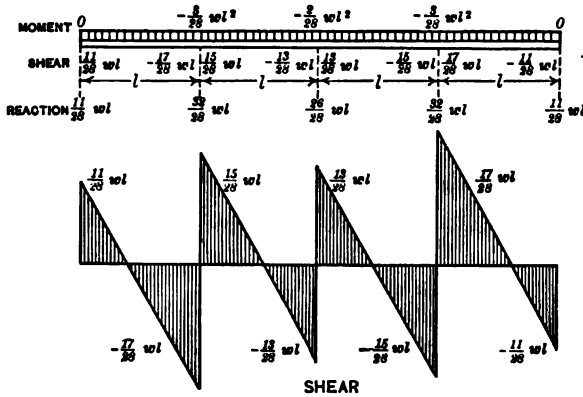

Fig. 108.

Fig. 108 gives moments, shears and reactions for a beam with four equal spans uniformly loaded with no overhang.

PROBLEMS.

3. Show that with three equal spans, uniformly loaded, the reactions are $0.4 wl$, $1.1 wl$, $1.1 wl$, and $0.4 wl$.

4. Calculate the reactions at the supports in Problem 3, Article 78.
Ans. $1.22 wl$, $0.86 wl$, $0.92 wl$.

5. In Problem 4, Article 78, calculate the shears and find the reactions.
Ans. Reactions, $8.45 w$, $7.30 w$, $8.80 w$, $5.45 w$.

6. Draw the shear diagrams for Problem 5. From this diagram find all dangerous sections and calculate the moment at each.
Ans. At 4.55 feet to the right of the third support $M = 3.95 w$.

7. A beam carrying a uniformly distributed load rests on three supports spaced 10 feet apart. How much should it overhang the outer supports in order that the reactions at all the supports shall be the same? *Ans.* 4.4 feet.

80. Theorem of Three Moments with a Single Concentrated Load on each Span. — Fig. 109 represents a continuous beam with a load P_1 on the first span at a distance $k_1 l_1$ from the left end and with a similar load P_2 at a distance $k_2 l_2$ from the left end of the second span, etc. Writing the equations for the first span as in Article 64,

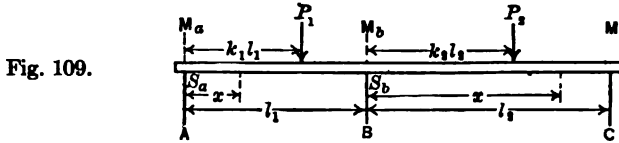

Fig. 109.

$$EI \frac{d^2y}{dx^2} = M_a + S_a x. \quad \left| \quad EI \frac{d^2y}{dx^2} = M_a + S_a x - P_1 (x - k_1 l_1). \right.$$

$$EI \frac{dy}{dx} = M_a x + \frac{S_a x^2}{2} + C_1. \quad (1) \quad \left| \quad EI \frac{dy}{dx} = M_a x + \frac{S_a x^2}{2} \right.$$

$$\quad \left. - \frac{P_1 (x - k_1 l_1)^2}{2} + C_3. \quad (3) \right.$$

$$C = C_3.$$

$$EI y = \frac{M_a x^2}{2} + \frac{S_a x^3}{6} + C_1 x \quad \left| \quad EI y = \frac{M_a x^2}{2} + \frac{S_a x^3}{6} \right.$$

$$+ [C_2 = 0]. \quad (5) \quad \left. - \frac{P_1 (x - k_1 l_1)^3}{6} + C_1 x \right.$$

$$\quad \left. + [C_4 = 0]. \quad (7) \right.$$

$$0 = 3 M_a l_1 + S_a l_1^2 - P_1 (1 - k)^2 l_1^2 + 6 C_1. \quad (9)$$

From the general equation of moments when there is no distributed load:

$$S_a = \frac{M_b - M_a}{l_1} + P_1 (1 - k_1). \quad (11)$$

Substituting in (7):

$$(2 M_a + M_b) l_1 + P_1 [(1 - k_1) - (1 - k_1)^3] l_1^2 + 6 C_1 = 0. \quad (13)$$

A similar set of equations may be written for the second span. We will give these the even numbers and represent the constants of integration by K_1 , etc.

$$EI \frac{dy}{dx} = M_b x + \frac{S_b x^2}{2} + K_1. \quad (2)$$

$$(2 M_b + M_c) l_2 + P_2 [(1 - k_2) - (1 - k_2)^3] l_2^2 + 6 K_1 = 0. \quad (14)$$

At support B , $\frac{dy}{dx}$ is the same for (3) and (2). Substituting $x = 0$ in (2) and $x = l_1$ in (3) and substituting the value of S_a in the latter, we get:

$$(M_a + M_b) l_1 + P_1 [(1 - k) - (1 - k)^2] l_1^2 + 2 C_1 = 2 K_1. \quad (15)$$

To eliminate the two unknowns C and K from (13), (14), and (15), multiply (15) by 3, and multiply (13) by -1 and add the results to (14).

$$M_a l_1 + 2 M_b (l_1 + l_2) + M_c l_2 + P_1 l_1^2 [2 (1 - k_1) - 3 (1 - k_1)^2 + (1 - k_1)^3] + P_2 l_2^2 [(1 - k_2) - (1 - k_2)^2] = 0. \quad (16)$$

Equation (16) is the equation of three moments for a single concentrated load in each span.

PROBLEMS.

1. A beam is supported at the ends and at the middle and carries a load P at the middle of each span. Find the moment at the middle support and the reactions at each support.

$$\text{Ans. } \begin{cases} \text{Moment at the middle, } -\frac{3 Pl}{16}. \\ \text{Reaction at end, } \frac{5 P}{16}. \end{cases}$$

Compare these results with a beam fixed at one end, supported at the other, and loaded at the middle, Article 70.

2. A shaft 30 feet long is supported at the ends and the middle. A load of 600 pounds is applied at the middle of the left span and a load of 400 pounds at the middle of the right span. Find reactions, the moment at each dangerous section, and the points of inflection.

81. Superimposed Loads. — In many cases we have concentrated loads superimposed on distributed loads. In the case of a cantilever we get the deflection and stress at any point by adding the deflections or stresses due to the separate loadings. The same is true of a beam supported at the ends. In the case of a beam supported at the ends with a concentrated load not at the middle and a distributed load, the sum of the separate deflections at any point gives the resulting deflection at that point, but the point of maximum deflection is between the position of the concentrated load and the middle of the beam. The dangerous section is either between the dangerous sections for the separate loads or under the concentrated load.

We have already learned to locate these dangerous sections by means of the shear diagram. It is seldom necessary to

locate exactly the point of maximum deflection. For a single concentrated load the maximum deflection is between the point of application and the middle of the beam and is nearer the latter. For a uniformly distributed load the maximum deflection is at the middle. There is little error in using the deflection at the middle in place of the maximum. If the maximum deflection due to the concentrated load is added to the deflection at the middle due to the distributed load the sum will be a trifle larger than the actual maximum resulting deflection.

PROBLEMS.

1. A 6-inch by 10-inch beam 20 feet long is supported at the ends and carries a distributed load including its own weight of 100 pounds per foot. If E is 1,000,000, find the maximum deflection and fiber stress.

Ans. 600 pounds per square inch, 0.72 inch.

2. If the beam of Problem 1 carries a concentrated load of 800 pounds 14 feet from the left end, what is the fiber stress under the load and at the middle due to this load alone? What is the deflection under the load and at the middle and what is the maximum deflection due to the concentrated load alone?

Ans. Stress under load, 403.2; at middle, 288 pounds; deflection under load, 0.325 inch; at middle, 0.365 inch; at 11 feet, 0.369 inch.

3. In Problems 1 and 2, if both loads are applied at the same time, what is the maximum fiber stress?

Ans. 922.6 pounds per square inch.

In Problem 3, if we wish to find the exact value of the maximum deflection we may solve the differential equation for distributed and concentrated loads combined. The equation for finding the point of maximum deflection is a cubic in x . The solution of this cubic for Problem 3 gives $x = 124$ inches. The maximum deflection is 1.086 inches which is practically the sum of the separate deflections at the middle.

PROBLEM.

4. Take the case of a beam fixed at the left end and supported at the right end. Solve the differential equations for a distributed load, a load concentrated at the middle, and for the two combined and compare the last with the sum of the others.

The reactions, moments, shears and deflections at any point due to a combination of loads may be obtained by taking the sum of the similar quantities for the loads separately. If we want the *maximum* moment we construct the shear diagram for the combined loads. We can generally locate the position of

maximum deflection approximately by inspection and determine the deflection for a few points. In Problem 3, above, the maximum deflection for the distributed load is at 10 feet, and for the concentrated load at 11 feet. We might compute the deflection for every 2 inches between these points and plot the curve for the maximum.

82. Moments in Different Planes. — It frequently happens that the forces acting upon a beam are not all in the same plane. A horizontal shaft may be subjected to a vertical load due to its weight and the weight of the pulleys, and to a force in some other direction due to the tension on belts. If a beam thus loaded has the same moment of inertia in all directions it is only necessary to find the resultant moment at any section, making use of the fact that moments are vector quantities and may be combined like forces or other vectors.

PROBLEMS.

1. A shaft 3 inches in diameter and 10 feet long weighs 24 pounds per foot. The shaft is supported at the left end and 2 feet from the right end. It carries a pulley weighing 64 pounds 1 foot from the right end, and a pulley weighing 40 pounds 2 feet from the left end. With these loads only, find the dangerous sections and the moment at each.

Ans. 3 feet from the left support, 188 foot pounds; at right support, 112 foot pounds.

2. If there is a horizontal pull of 80 pounds on the right pulley perpendicular to the shaft, what is the resulting moment at the right bearing?

Ans. 137.6 foot pounds.

3. In Problem 2 what is the resultant moment 3 feet from the left support?

Ans. 190.4 foot pounds.

The maximum resulting moment is a little to the right of the dangerous section for the vertical loads. Its exact position in this case involves the solution of a cubic equation.

4. Write the expression for the square of the resultant moment for points between the left pulley and the right bearing. Find the expression for the position of the resultant dangerous section and solve by method of trial to two significant figures.

5. Solve Problems 2 and 3 if the pull of 80 pounds is 30 degrees below the horizontal.

Find the resultant of two couples at 60 degrees with each other, or resolve the 80 pounds into its vertical and horizontal components, adding the vertical component to the vertical loads and using the horizontal component as you used the pull when it was horizontal.

When a beam is subjected to forces which are not parallel to one of the principal axes of inertia (and perpendicular to the

other), it is necessary to resolve these forces parallel to the principal axes. Then find the unit stress at any point in the section separately for both sets of forces and add the results.

PROBLEMS.

6. A 6-inch by 8-inch beam 15 feet long is supported at the ends and carries a load of 800 pounds at the middle. The load is 30 degrees from the vertical in a plane normal to the length of the beam. Find the unit stress at each corner at the dangerous section.

The principal axes of inertia are horizontal and vertical. The vertical component of the load is 692.8 pounds and the horizontal component is 400 pounds. Using the horizontal component as applied at *D* (Fig. 110, I), we

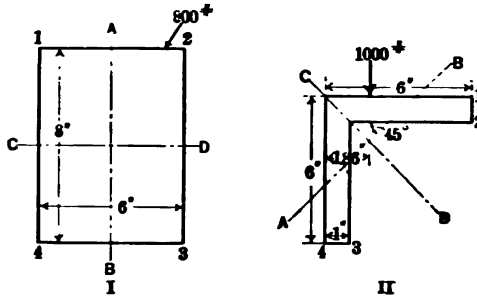

Fig. 110.

find a unit stress of 375 pounds per square inch which is tensile on the left side, 1-4, and compressive on the right side. Using the vertical component as applied at *A*, with *CD* as the axis of inertia, we get 487 pounds which is compressive at the top. The unit stress at corner 2 is 862 pounds per square inch compression. At corner 1 it is 112 pounds compression.

7. A 6-inch by 6-inch by 1-inch standard angle, 10 feet long, is used as a beam supported at the ends. The angle is placed with legs horizontal and vertical (Fig. 110, II), and a load of 1000 pounds is applied at the middle, over the center of gravity of the section. Find stresses at corners.

Here the principal axes are *AB* for which I is 14.78, and *CD* for which I is 56.14. The external moment for each axis is $15,000\sqrt{2}$.

$$\text{Unit stress at } C = \frac{15,000 \times \sqrt{2} \times 1.86 \times \sqrt{2}}{14.78} = 3775 \text{ pounds.}$$

The unit tensile stress at 3 due to the moment about the axis *AB* is 3329 pounds. The tensile stress due to the moment about *CD* is 1336 pounds. The total tensile stress at this corner is 4665 pounds. What is the total unit stress at corner 2? How do you know that the stress at 4 is less than at 3? Compute the stress at 1.

8. Find the horizontal and vertical components of the deflection at the middle in Problem 7 if E is 30,000,000.

Solve for each axis separately, then resolve deflections horizontally and vertically and add.

CHAPTER IX.

SHEAR IN BEAMS.

83. **Direction of Shear.** — The total vertical shear in beams is calculated by the methods of Article 45. We have learned nothing so far in regard to *distribution* of the shearing stress. In Article 30, we learned that shearing stresses occur in pairs, that a small block subjected to a shearing stress of a given intensity along two parallel vertical faces is subjected to a shearing stress of the same intensity along two horizontal faces.

Fig. 111, I, represents a beam made by placing one plank on top of another. Fig. 111, II, is the same beam under load,

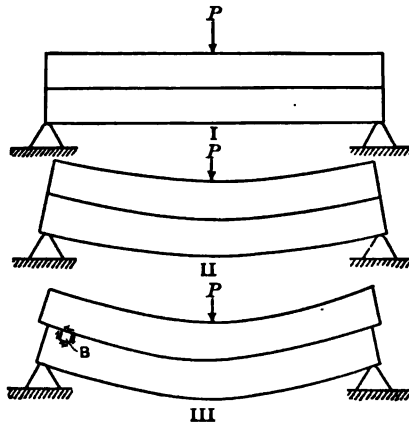

Fig. 111.

provided that the planks are held from slipping with reference to each other by being glued or bolted together to form a single beam. If the planks are free to move, they take the form III, in which the upper plank is moved outward over the lower one at each end. Consider a small block *B* in the upper portion of the lower plank. The plank above this block has been displaced to the left. If they were glued together, the upper plank would have exerted a horizontal shearing stress upon the upper surface of the block. To prevent rotation there must be a vertical shear

upwards at the left side. The actual shearing stresses upon this block from the surrounding material, if the upper plank were glued to the lower, would take the directions of the arrows.

The shear at the left of the block is vertically upward, which is the direction of the external shear. If we used a small block to the right of the load P we would find that the shear on its left side was vertically downward. This is the direction of the external shear in this half of the beam. One of the planks in Fig. 111 may be thicker than the other, which shows that the results apply to all parts of a vertical section in so far as they effect the direction of the shearing stress.

➤ **84. Intensity of Shearing Stress.** — To determine the intensity of the shearing stress we will consider Fig. 112. This

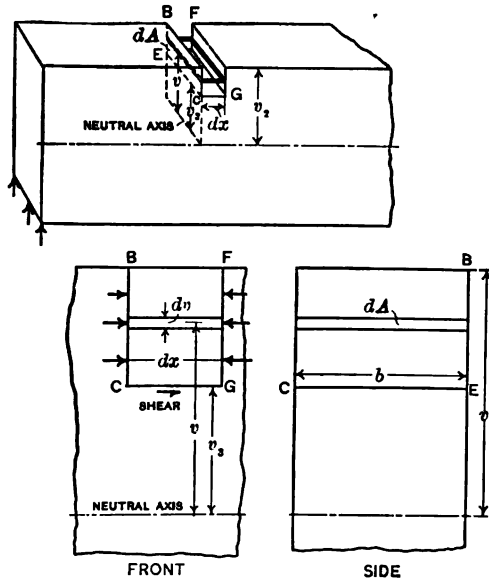

Fig. 112. — Horizontal Shear in a Beam.

represents a part of a beam. Imagine a small block extending across the beam between planes dx apart and extending from the top of the beam to a plane at a distance v_3 from the neutral surface. This block is in equilibrium under the action of the direct stress, tension or compression, acting on the ends (the rectangles whose diagonals are CB and GF) and a shearing stress

from the material below acting on the bottom (on the rectangle whose diagonal is GE).

Consider a small area dA in the left end of this block. The unit tensile (or compressive) stress on this area is $\frac{M_1 v}{I_1}$ where M_1 is the bending moment at the section and I_1 is the moment of inertia of the *entire cross section* of the beam with respect to the neutral axis. The total tension (or compression) on the left end of this block is the integral of the unit stress over the left end of the block:

$$\text{Total tension on left end} = \frac{M_1}{I_1} \int_{v_1}^{v_2} v dA. \quad (1)$$

In the same way, the total tension (or compression) on the right end of the block is:

$$\text{Total tension on right end} = \frac{M_2}{I_2} \int_{v_1}^{v_2} v dA. \quad (2)$$

The resultant horizontal pull (or push) on the block in the direction of the length of the beam is the difference of these integrals (1) and (2). If the section of the beam is uniform $I_1 = I_2$ and v_1 and v_2 are the same for both expressions. The resultant horizontal pull (or push) becomes:

$$\text{Resultant force} = \frac{M_2 - M_1}{I} \int_{v_1}^{v_2} v dA. \quad (3)$$

This resultant horizontal force must be balanced by the horizontal shear at the bottom of the block. If the breadth CE at the bottom of the block is b , the total area in horizontal shear is $b dx$, and the total shear is $s_s b dx$. Equating these forces:

$$s_s b dx = \frac{M_2 - M_1}{I} \int_{v_1}^{v_2} v dA; \quad (4)$$

$$s_s = \frac{M_2 - M_1}{I b dx} \int_{v_1}^{v_2} v dA. \quad (5)$$

Since $M_2 - M_1$ is equal to dM ,

$$\frac{M_2 - M_1}{dx} = \frac{dM}{dx} = S, \quad (6)$$

where S is the total vertical shear.

$$s_s = \frac{S}{I b} \int_{v_1}^{v_2} v dA, \quad \text{Formula XVIII.} \quad (7)$$

where s_x equals the unit horizontal shear at a distance v_x from the neutral axis and also equals the unit vertical shear at the same place. The term $\int_{v_x}^{v_1} v dA$ is the moment of the area of the end of the block with respect to the neutral axis.

$$\bar{v} = \frac{\int_{v_x}^{v_1} v dA}{A}; \int_{v_x}^{v_1} v dA = \bar{v}A. \quad (8)$$

When the area and location of the center of gravity of the portion of the plane section above the line CE are known, the integral may be replaced by the equivalent expression of (8).

PROBLEMS.

1. Find the unit shearing stress in a 4-inch by 6-inch beam at points 1 inch above the neutral axis, if the total vertical shear is 1440 pounds. Find $\int v dA$ both ways and check.

$$\text{Ans. } \int_1^8 v dA = 4 \int_1^2 v dv = 2 [v^2]_1^2 = 16;$$

$$\bar{v}A = 2 \times 8 = 16;$$

$$s_x = \frac{1440}{72 \times 4} \times 16 = 80 \text{ pounds per square inch.}$$

2. In Problem 1, find the unit shearing stress at the neutral surface. Also find the average shearing stress by dividing the total vertical shear by the cross section.

Ans. Unit shear at the neutral surface, 90 pounds per square inch. Average shearing stress 60 pounds per square inch.

3. Show algebraically that in beams of rectangular section the average unit shear is two-thirds as great as the shear at the neutral surface.

4. A 6-inch by 8-inch beam 10 feet long, supported at the ends, carries a load of 6000 pounds 4 feet from the left end. Find the unit shearing stress at the neutral surface just to the right of the left support, using the result of Problem 3.

Ans. 112.5 pounds per square inch.

5. In Problem 4 find the unit shearing stress 1 inch from the top and 2 inches from the top near the left support.

Ans. 49.21 and 84.37 pounds per square inch.

6. In Problem 4 find the unit shearing stress 3 inches from the top and five inches from the top.

7. In a beam of solid circular section what is the ratio of the unit stress at the neutral surface to the average unit shearing stress?

Ans. 4 : 3.

8. What is the maximum load which can be placed on a short 6-inch by 6-inch beam supported at the ends, if the allowable unit shearing stress parallel to the grain is 150 pounds per square inch?

Ans. 7200 pounds if placed at the middle; 3600 pounds if placed near the end.

9. Calculate the unit shearing stress in terms of the total shear in the web of a 10-inch 25-pound I-beam at the neutral surface and at the bottom of the flange.

Ans. $s_s = 0.368 S$ at the neutral surface.

$s_s = 0.291 S$ at the bottom of the flange.

10. In practice, engineers calculate the unit shearing stress in I-beams by dividing the total shear by the area of cross section of web regarded as extending the entire depth of the beam (see Cambria). What is the average unit stress by this method in the beam of Problem 9? *Ans.* $0.323 S$.

11.* A 7-inch by 14-inch beam of long-leaf yellow pine, placed on supports 13 feet 6 inches apart, was subjected to equal loads at points 4 feet 6 inches from the supports. When the total load was 57,500 pounds, the beam failed by shear at the neutral axis at one end. Find the ultimate shearing strength of this timber parallel to the grain. Compare the result with the figures given by the United States Department of Agriculture (see Cambria).

Ans. 440 pounds per square inch.

12.* A 7-inch by 16-inch beam of Douglas fir, supported near the ends and loaded at the third points with equal loads, failed by shear when the total load was 45,000 pounds. Find the ultimate shearing strength of this timber parallel to the grain.

Ans. 301 pounds per square inch.

13. Timber having an allowable shearing stress of 100 pounds and an allowable bending stress of 1000 pounds is used for beams supported near the ends with uniformly distributed loads. Below what length will the shear determine the load in a 6-inch by 6-inch beam? in a 4-inch by 8-inch beam?

Ans. For a 6-inch by 6-inch beam, 5 feet.

For a 4-inch by 8-inch beam, 6 feet 8 inches.

14. Using the allowable stresses of Problem 13, what is the total safe load uniformly distributed, on a 6-inch by 6-inch beam supported at the ends when the length is 4 feet? when the length is 6 feet?

Ans. 4800 pounds, 4000 pounds.

The total horizontal shear at any horizontal plane in a beam is proportional to the area of the stress distribution diagram (Article 54), above or below this plane; and the unit shearing stress is proportional to the quotient of this area divided by b . The unit stress at a distance v from the neutral axis varies as v ; the stress on an area dA is $kvdA$; and the total stress on an area extending from a plane at a distance v_1 from the neutral axis to the top of the beam, is $k \int_{v_1}^{v_2} vdA$.

In a rectangular section (Fig. 81) the stress-distribution diagram is a triangle. If b is the breadth and v_2 the distance to the top from the neutral axis, the area of this triangle is $\frac{bv_2}{2}$; at a point half way to the top, the area is reduced one-fourth so that

* Problems 11 and 12 are from tests made by Professor A. N. Talbot, described in Bulletin 41 of the Engineering Experiment Station of The University of Illinois.

it is evident that the unit shearing stress at the latter point is $\frac{3}{4}$ as great as at the neutral axis. In an I-beam (Fig. 82), most of the shaded area representing the stress distribution is in the flange. The small shaded area in the web measures the difference between the shearing stress at the neutral axis and that at the bottom of the flange.

PROBLEM.

15. A beam of rectangular section, 10 inches deep, has a unit shearing stress of 150 pounds per square inch at the neutral surface. Find the unit shearing stress at each inch above the axis by means of the stress-distribution triangle.
Ans. 144, 126, 96, and 54 pounds per square inch.

85. Resultant of Shearing and Tensile Stress. — Fig. 113 represents a block of breadth dx , height dy , and length l , subjected

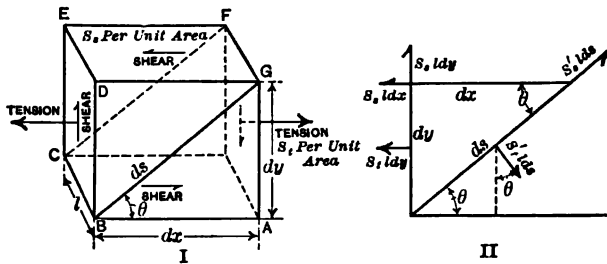

Fig. 113. — Combined Shear and Tension.

to tensile stresses of intensity s_x perpendicular to the left and right vertical faces, to shearing stresses of intensity s_y parallel to these faces, and to shearing stresses of equal intensity in the top and bottom faces. The shear on the left face is upward and on the top face toward the left. We wish to find the shearing stress parallel to the diagonals BG or CF and the tensile stress normal to the plane $BCFG$. We will consider the block as divided into two equal triangular prisms by the plane $BCFG$ and will take the prism on the left of the plane as the free body in equilibrium. The forces which act on this free body are five in number:

Total tension $s_x dy$, towards the left, applied at center of $BCED$;

Total shear $s_y dy$, upward, applied at center of $BCED$;

Total shear $s_x dx$, towards the left, applied at center of $DEFG$;

Total shear on $BCFG$, parallel to BG , applied at center of $BCFG$;

Total tension normal to $BCFG$ at its center.

We will represent the unknown unit shearing stress in the diagonal plane by s_s' , and the unknown tensile stress by s_t' . The total shear on this plane is then $s_s'ld$, where ds is the length of the diagonal BG . The total tension on the diagonal plane is $s_t'ld$. We will determine the magnitude of these unknown forces by resolving parallel to BG and normal to the plane $BCFG$. These five forces are represented in a single plane in Figure 113, II. Resolving parallel to BG and dividing by l ,

$$s_s'dy \cos \theta + s_s'dx \cos \theta - s_t'dy \sin \theta = s_s' ds, \quad (1)$$

where θ is the angle between the plane $BCFG$ and the horizontal.

Dividing by ds and substituting for $\frac{dx}{ds}$ and $\frac{dy}{ds}$:

$$s_s' = s_t \sin \theta \cos \theta + s_s [\cos^2 \theta - \sin^2 \theta], \quad (2)$$

$$s_s' = s_t \frac{\sin 2\theta}{2} + s_s \cos 2\theta. \quad (3)$$

Resolving normal to ds :

$$s_t'dy \sin \theta + s_s'dx \sin \theta + s_s'dy \cos \theta = s_t' ds. \quad (4)$$

$$s_t' = s_t \sin^2 \theta + 2 s_s \sin \theta \cos \theta, \quad (5)$$

$$s_t' = s_t \frac{1 - \cos 2\theta}{2} + s_s \sin 2\theta. \quad (6)$$

These equations apply when the external shearing stresses in the block have the directions of Fig. 113. If the shear is reversed some of the signs are changed.

PROBLEMS.

1. With the unit shearing stress 100 pounds per square inch and the unit tensile stress in the same direction 400 pounds per square inch (Fig. 114), find the resultant unit shearing stress along a plane making an angle of 20 degrees with the direction of the tension. Also find the unit tensile stress normal to this plane.

Ans. s_s' , 205; s_t' , 111 pounds per square inch.

2. With unit shearing stress 100 pounds per square inch and unit tensile stress zero, find the resultant tensile stress and shearing stress at 45 degrees.

Ans. s_t' , 100; s_s' , 0.

86. Maximum Resultant Stress. — To find the direction that the plane $BCFG$ should have in order that the shearing stress along it shall be a maximum, differentiate the expression for s_s' , Article 85, (3), with respect to θ :

$$\frac{d}{d\theta}(s_t') = s_t \cos 2\theta - 2s_s \sin 2\theta = 0 \text{ for maximum or minimum, (1)}$$

$$\tan 2\theta_s = \frac{s_t}{2s_s}. \quad (2)$$

To find the direction of the plane in order that the unit tensile stress across it shall be a maximum or a minimum:

$$s_t \sin 2\theta + 2s_s \cos 2\theta = 0, \quad (3)$$

$$\tan 2\theta_t = -\frac{2s_s}{s_t}. \quad (4)$$

The angle of equation (4) is normal to that of (2), consequently the direction of maximum shear is 45 degrees from the direction of maximum tension.

PROBLEMS.

1. In Problem 1, Article 85, find the direction of the maximum tension and shear.

$$\begin{aligned} \tan 2\theta_s &= \frac{118}{59} = 2. \\ 2\theta_s &= 63^\circ 26' \text{ or } 243^\circ 26'. \\ \sin 2\theta_s &= 0.8944 \text{ " } - 0.8944. \\ \cos 2\theta_s &= 0.4472 \text{ " } - 0.4472. \\ \frac{s_t}{2} \sin 2\theta &= 178.88 \text{ " } - 178.88. \\ s_s \cos 2\theta &= 44.72 \text{ " } - 44.72. \\ s_t' &= 223.60 \text{ " } - 223.60. \\ \theta_s &= 31^\circ 43' \text{ " } 121^\circ 43'. \end{aligned}$$

Fig. 114, II, shows the direction of the maximum resultant shearing stress. At $31^\circ 43'$ the portion below the line exerts a shear to the right on the portion above. At $121^\circ 43'$ the portion on the side of the line in which the angle is measured exerts a negative shear on the other side and the arrow representing positive shear (away from the origin) is on the other side. Fig. 114, III, shows how the shears act on the element of volume.

For the maximum resultant tensile stress,

$$\begin{aligned} \tan 2\theta &= -\frac{1}{2}. \\ 2\theta &= 153^\circ 26' \text{ or } 333^\circ 26'. \\ \sin 2\theta &= 0.4472 \text{ " } - 0.4472. \\ \cos 2\theta &= -0.8894 \text{ " } 0.8894. \\ s_s \sin 2\theta &= 44.72 \text{ " } - 44.72. \\ \frac{s_t}{2}(1 - \cos 2\theta) &= 378.88 \text{ " } 21.12. \\ \text{Max } s_t' &= 423.60 \text{ " } - 23.60. \end{aligned}$$

Fig. 114, IV, shows the direction and relative magnitude of these unit stresses. Note that the minimum is a compressive stress, along a line normal to the maximum tension.

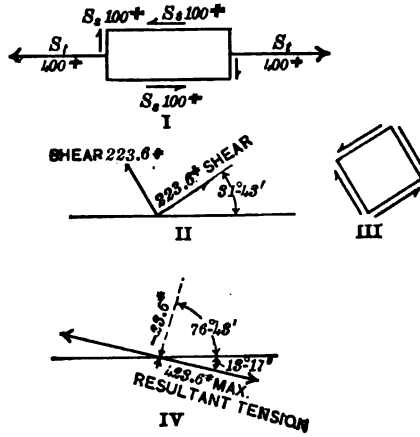

Fig. 114. — Shear and Tension.

2. With unit compressive stress of 200 pounds per square inch and unit shearing stress of 160 pounds per square inch, find the maximum resultant shear and compression (Fig. 115).

$$\begin{aligned} \tan 2\theta_s &= \frac{-200}{320} = -0.625. \\ 2\theta_s &= 148^\circ \text{ or } 328^\circ. \\ \max s_s' &= -188.68 \text{ " } 188.68. \\ \tan 2\theta_t &= 1.600. \\ \theta_t &= 29^\circ \text{ or } 119^\circ. \\ \max s_t' &= 88.68 \text{ " } -288.68. \end{aligned}$$

Fig. 115, II, shows the shearing stress. The shear at 74 degrees is negative and is downwards towards the origin on the right side of the line. At 164 degrees the shear is positive, away from the origin on the upper side. We have drawn the shear at -16 degrees, instead of along the opposite line. Fig. 115, III, shows all the maximum shearing stresses acting on a block in the solid.

The maximum stress along the 29-degree line is compressive, and the minimum along the line at right angles to this is tensile (Fig. 115, IV).

To find the maximum resultant shearing stress without calculating the angle $2\theta_s$, substitute in

$$s_s' = \frac{s_t}{2} \sin 2\theta + s_s \cos 2\theta,$$

the values of $\sin 2\theta$ and $\cos 2\theta$ calculated from the relation

$$\tan 2\theta_s = \frac{s_t}{2s_s};$$

from which we get

$$\max s_s' = \sqrt{s_s^2 + \left(\frac{s_t}{2}\right)^2}. \quad \text{Formula XIX}$$

In a similar way substitute the values of $\cos 2\theta$ and $\sin 2\theta$ from

$$\tan 2\theta_t = -\frac{2s_s}{s_t}$$

in equation (6) of Article 85, and get

$$\max s_t' = \frac{s_t}{2} \pm \sqrt{s_s^2 + \left(\frac{s_t}{2}\right)^2} = \frac{s_t}{2} \pm \max s_s'. \quad \text{Formula XX.}$$

Generally it is best to calculate the value of $\max s_s'$ from equation (3) of Article 85 and then get maximum s_t' from the second relation of Formula XX.

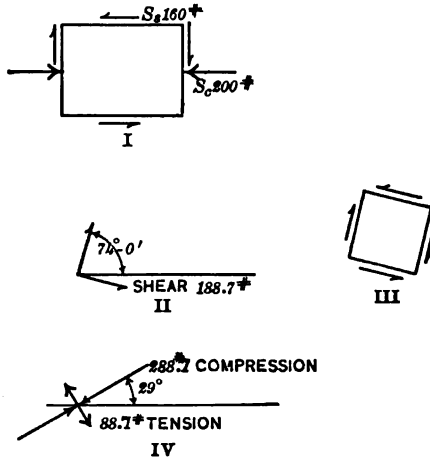

Fig. 115. — Resultant of Shear and Compression.

3. Find the maximum resultant shearing and tensile stresses due to a horizontal tension of 300 pounds per square inch and a shearing stress of 160 pounds per square inch.

Ans. $\tan 2\theta_s = 0.9375$; $\theta_s = 21^\circ 35'$; $\max s_s' = 219.28$ pounds;
 $111^\circ 35'$; $- 219.28$ "
 $\max s_t' = 369.28$ "
 $- 69.28$ "

To find the direction of the larger tensile stress we notice that the tension produced by the shear alone (Fig. 116, I) takes the direction OC . The re-

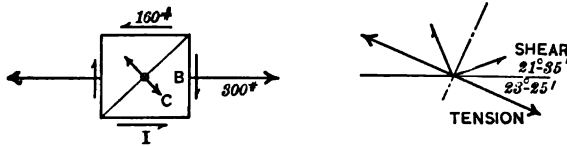

Fig. 116.

sultant maximum tension lies between this direction and the horizontal. To get this position measure backward 45 degrees from the position of maximum shear.

4. A 6-inch by 10-inch beam rests on two supports 30 inches apart and carries a load of 20,000 pounds at the middle. Find the tensile and shearing

$$\frac{3M + N^2}{2} = \frac{16}{9} \frac{P^2}{D^3}$$

$$s_s = 160$$

stress 5 inches from the left support and 3 inches from the bottom of the beam. Find also the maximum resultant stresses.

$$s_s = 210 \text{ pounds}; s_t = 200 \text{ pounds};$$

$$\max s_s' = 232.6 \text{ pounds}; \max s_t' = 332.6 \text{ pounds}; \min s_t' = -132.6 \text{ pounds};$$

$$\theta_s = 12^\circ 44'; \quad \theta_t = -32^\circ 16'; \quad \theta_t = 57^\circ 44'.$$

87. Resultant Stress in Beams. — In beams, the maximum tensile stress is in the outer fibers, while the maximum shearing stress is at the neutral axis. The shear is a maximum where the tension is zero and the tension is a maximum where the shear is zero. For these reasons it is not generally necessary to compute the resultant stress when the beam is made of material which is equally strong in all directions. There are conditions, however, where the maximum resultant stress becomes an important factor. We will, therefore, work out a problem to show the ways in which these stresses act.

PROBLEM.

1. A 6-inch by 10-inch beam is supported at points 30 inches apart and supports a load of 20,000 pounds midway between the supports. Find the magnitude and direction of the maximum resultant tension, shear, and compression, at sections 5 inches and 10 inches from the left support at points 0, 1, 2, 3, 4, and 5 inches from the neutral axis.

TABLE VI.

RESULTANT SHEAR AND TENSION IN A BEAM.

Distance below axis.	Shear.		Tension.		Maximum shear.		Maximum tension.		Maximum compression.	
	Pounds.	Pounds.	Pounds.	Angle.	Pounds.	Angle.	Pounds.	Angle.	Pounds.	Angle.
At 5 inches from end.	0	250	0	250.0	0° 0'	250.0	-45° 0'	250	45° 0'	
	1	240	100	245.2	5° 53'	295.2	-39° 07'	195.2	50° 53'	
	2	210	200	232.6	12° 44'	332.6	-32° 16'	132.6	57° 44'	
	3	160	300	219.3	21° 35'	369.3	-23° 25'	69.3	66° 35'	
	4	90	400	219.0	32° 53'	419.0	-12° 07'	19.0	77° 53'	
	5	0	500	250.0	45° 0'	500.0	0° 0'	0	90° 0'	
At 10 inches from end.	0	250	0	250.0	0° 0'	250.0	-45° 0'	250.0	45° 0'	
	1	240	200	260.2	11° 49'	360.2	-33° 11'	160.2	56° 49'	
	2	210	400	290.0	21° 48'	490.0	-23° 12'	90.0	66° 48'	
	3	160	600	341.0	30° 58'	641.0	-14° 2'	41.0	75° 58'	
	4	90	800	410.0	38° 40'	841.0	-6° 20'	10.0	83° 40'	
	5	-0	1000	500.0	45° 0'	1000.0	0° 0'	0	90° 0'	

Above the neutral axis the shear is the same as below and the tension and compression change places. The angles are numerically the same but are on

opposite sides of the horizontal. Fig. 117 shows the direction and relative magnitude of the maximum and minimum stresses for this problem. Near the bottom where the maximum compression is small its direction is shown by the dotted lines. In the same way the direction of the tension is indicated near the top.

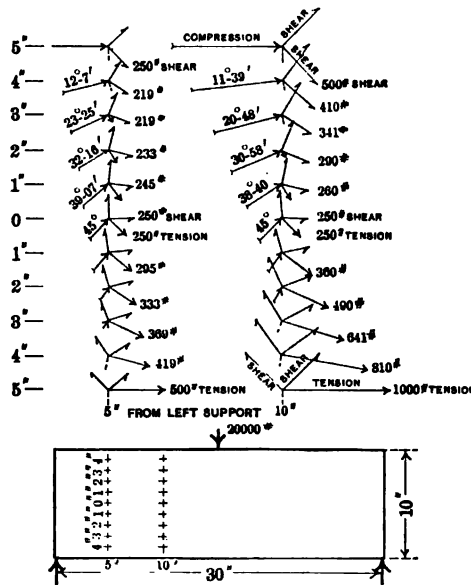

Fig. 117. — Resultant Stress in a Beam Section.

88. **Failure of Beams.** — The nature of the failure in a beam depends principally upon the relative ultimate strength of the material in the different directions and the value of the different maximum stresses. In a beam which is short relative to its depth, the unit tensile and compressive stresses at the dangerous section are small compared with the unit shearing stress at the neutral surface at the ends. Owing to the fact that timber has a small shearing strength parallel to the grain such a beam, if made of timber, will usually fail by shear. Fig. 118 shows 4 wooden beams each about 40 inches long. The upper beam is a yellow pine beam glued to a white pine beam. The total depth was 3.80 inches and breadth 1.57 inches. The beam was supported at points 36 inches apart and loaded at the third points; this beam failed by longitudinal shear at one end when the total load was 1950 pounds. The failure followed the glued surface but began in the white pine.

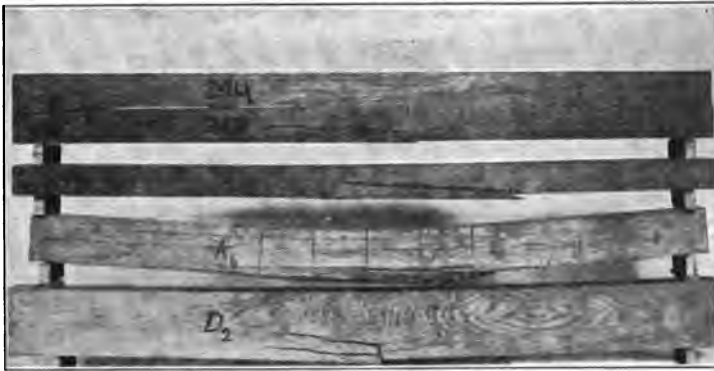

Fig. 118. — Failure of Timber Beams.

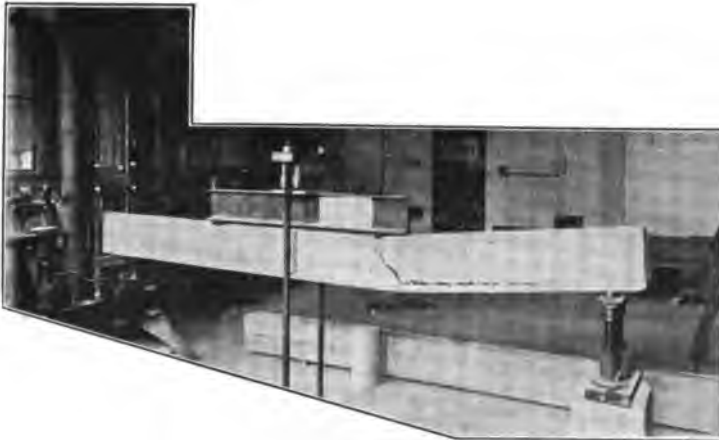

Fig. 119. — Failure of a Reinforced Concrete Beam.

The second beam of white pine 3.81 inches by 1.68 inches, loaded in the same way with the large dimension horizontal, failed by tension under a total load of 2467 pounds.

The lower beam is hickory, 2.39 inches by 3.79 inches. It failed by tension under a total load of 12,900 pounds. The beam next to the bottom, 2.02 inches by 2.16 inches is also hickory. It failed under a load of 5540 pounds.

PROBLEMS.

1. Find the ultimate shearing strength of the white pine of the upper beam. What was the unit tensile stress when it failed?
2. Find the unit tensile stress at the middle and the unit shearing stress at the ends for the white pine stick.
3. Find the ultimate bending strength of hickory from the two samples; also find the lower limit for the shearing strength.

Fig. 119 shows a reinforced concrete beam supported near the ends at points 12 feet apart and loaded at the third point. The diagonal line shows the initial failure. This is frequently called a shear failure. It is really failure by tension. The line of failure is about normal to the direction of the maximum

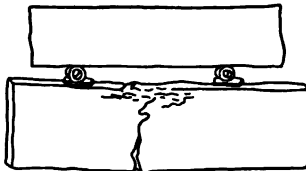

Fig. 120.

resultant tensile stress. Of course, as the direction of this stress is determined by the magnitude of the shear there is good reason for calling it a shear failure. The upper part of this crack does not follow a direction normal to the resultant tensile stress, but it must be remembered that, as the crack extended up in the beam, the direction of the resultant stress changed. In a beam loaded in this way, when cracks develop in the portion between the loads where the shear is zero, the line of fracture is vertical.

Fig. 120 shows failure of a concrete beam by compression.

Lewis P. McGilvary
Elect. Eng. 1916

CHAPTER X.

BEAMS OF SPECIAL FORM.

89. **Beams of Constant Strength.** — A beam of "constant strength" is one in which the section modulus varies as the moment, so that the extreme fiber stress in all sections is the same. To design such a beam, we write the moment expression and solve for the section modulus in terms of this expression and the allowable unit stress in the outer fibers.

90. **Cantilever with a Load on the End.** — If we regard the cantilever as fixed at the right end and take the left end as the origin of coördinates, the moment at a distance x from this origin is Px . If s is the allowable unit stress,

$$Px = s \text{ multiplied by the section modulus.}$$

For a rectangular section the section modulus is $\frac{bd^2}{6}$, and

$$Px = \frac{sbd^2}{6}.$$

PROBLEMS.

1. A cantilever of constant strength with the load on the end is of rectangular section of constant depth 6 inches. The allowable fiber stress is 800 pounds per square inch. Find the equation for the breadth.

$$\text{Ans. } b = \frac{Px}{4800}.$$

2. A cantilever beam of constant strength and rectangular section has a constant breadth b . If the allowable unit stress is s , find the expression for the depth for a load on the free end.

$$\text{Ans. } d^2 = \frac{6Px}{sb}.$$

3. A cantilever of constant strength with load of 600 pounds at the free end is 4 inches wide throughout. The section is rectangular. The allowable fiber stress is 1200 pounds per square inch. If the length is 60 inches from the load to the fixed point, find the depth at each 10 inches.

$$\text{Ans. } \begin{cases} \text{Position: } 10 & 20 & 30 & 40 & 50 & 60 \text{ inches.} \\ \text{Depth: } 2.74 & 3.87 & 4.74 & 5.48 & 6.12 & 6.71 \text{ inches.} \end{cases}$$

4. A cantilever 5 feet long carries a load of 800 pounds at the free end. The section is a rectangle with the depth twice the breadth. The allowable stress is 1000 pounds per square inch. Find the depth at each 10 inches.

$$\text{Ans. } \begin{cases} \text{Position: } 10 & 20 & 30 & 40 & 50 & 60 \text{ inches.} \\ \text{Depth: } 4.58 & 5.77 & 6.60 & 7.27 & 7.83 & 8.32 \text{ inches.} \end{cases}$$

5. A cantilever of constant strength 6 feet long carries a load at the free end. The depth at the wall is 8 inches and the breadth is constant. Find the depth at each foot. *Ans.* 3.27, 4.62, 5.66, 6.53, 7.30, 8.00 inches.

Fig. 121 shows some cantilevers of constant strength and rectangular section. Fig. 121, I, is a beam of constant depth. The breadth varies as x — the equation of a straight line. The plan is a triangle. Fig. 121, II, represents a beam with breadth constant. The depth varies as the square root of x — the equation of a parabola. One surface may be plane as in II or both may be curved as in Fig. 121, III. In any case the equation gives the total depth. Fig. 121, IV, represents a cantilever in which both depth and breadth vary, all sections being similar rectangles. The equation is that of the cubical parabola.

PROBLEM.

6. A circular steel post 20 inches long is used as a cantilever with a load at the end. The allowable unit stress is 12,000 pounds per square inch. Find the diameter at each 5-inch interval, if the load is 600 pounds.

91. Shearing and Bearing Stresses at the End. — In Fig. 121, the load P is represented at the extreme ends of the beams.

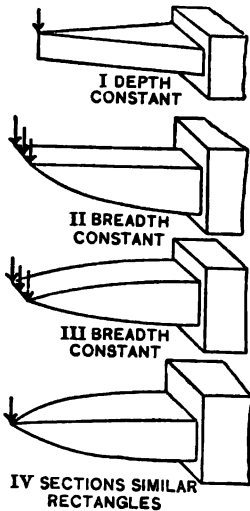

Fig. 121. — Cantilevers of Constant Strength.

Allowance must be made at the ends for bearing and shearing stresses. For instance, in Problem 3 of Article 90, suppose the allowable unit shearing stress to be 200 pounds per square inch. The section should never be less than 3 square inches; the minimum depth should be $\frac{3}{4}$ inch. Suppose also that the allowable bearing stress is 300 pounds per square inch, and that the center of the load must be 5 feet from the wall; the bearing area must be at least 2 square inches. If the load extends the entire width of the beam the bearing area must be 4 inches by $\frac{1}{2}$ inch. The actual beam must extend at least $\frac{1}{4}$ inch

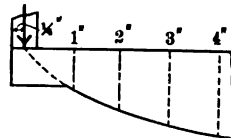

Fig. 122. — Requirements for Shear and Bearing.

beyond the center of the load. Fig. 122 shows the details for these conditions. The dotted lines are the limits for the beam

figured for bending only. The solid lines show the *minimum* dimensions figured for all stresses. The actual beam should be somewhat larger at the end than shown, as a great increase in safety can be secured here with practically no increase in cost and weight. Artistic appearance and convenience of construction may cause further modifications *outside* of the *minimum dimensions*.

PROBLEMS.

1. Design a cantilever of constant strength for a load of 500 pounds at a distance of 40 inches from a wall: the maximum bending stress to be 800 pounds; the maximum shearing stress, 100 pounds; and the maximum bearing stress, 200 pounds per square inch. The depth of the beam is constant, 4 inches.

2. Design the same cantilever with square section, all other conditions remaining the same as in Problem 1.

92. **Cantilever with Uniformly Distributed Load.** — The only difference between a cantilever with uniformly distributed load and one with a concentrated load is in the expression for the external moment.

PROBLEMS.

1. A cantilever of constant strength has a rectangular section and constant breadth b . The load is uniformly distributed and is w pounds per inch of length. If s is the allowable unit stress, find the expression for the depth.

$$\text{Ans. } d^2 = \frac{3wx^2}{sb}$$

2. Draw a cantilever of constant strength and constant breadth of 2 inches to carry a load of 180 pounds per foot uniformly distributed, with an allowable unit stress of 1000 pounds per square inch. The length of the cantilever is 40 inches.

3. A cantilever of constant strength of rectangular section is d inches deep. If the load is uniformly distributed, find the expression for the breadth.

$$\text{Ans. } b = \frac{3wx^2}{sd^2}$$

4. Draw a cantilever to satisfy the conditions of Problem 3. The breadth at the wall shall be 6 inches, and the length 30 inches.

5. A cantilever of constant strength, of rectangular section, carries a distributed load of 60 pounds per foot. The depth is 4 inches and the allowable unit stress is 800 pounds per square inch. Find the breadth for every 10 inches for a length of 5 feet.

6. A cantilever of square section for a uniformly distributed load is 6 inches square at the wall 40 inches from the free end. Find the dimensions at each 10 inches.

$$\text{Ans. } 2.38, 3.78, 4.95 \text{ inches.}$$

7. Design and draw a cantilever of constant strength and constant breadth of 2 inches to carry a distributed load of 100 pounds per foot and a load of

400 pounds 2 feet from the free end. The length of the cantilever is 4 feet and the allowable stress is 600 pounds per square inch.

8. A cantilever of constant strength for a uniformly distributed load has all sections similar triangles. At 50 inches from the free end it is 8 inches wide and 6 inches deep. Find the dimensions at each 10-inch interval.

93. Beams of Constant Strength Supported at the Ends.— The methods of solution are the same as for cantilevers. For a single load at the middle the problem is exactly the same as that of a cantilever of one-half the length with a load at the end. A beam with a single load at any point may be regarded as made of two cantilevers fixed at that point with loads equal to the respective end reactions. Beams with distributed loads are not quite so simple. Allowance must be made in this beam for shear and bearing at the supports, which was not necessary in the case of cantilevers with uniformly distributed loads.

PROBLEMS.

1. A box girder is made of two 12-inch 35-pound channels riveted to a pair of 10-inch by $\frac{1}{2}$ -inch plates extending the entire length and other similar plates extending part of the length on both sides of the middle. The load is 600 pounds per foot; the span is 40 feet; and the allowable unit stress is 10,000 pounds per square inch. Find the minimum length of these plates, making no allowance for weakening due to rivet holes.

Ans. One pair of plates should be 22 feet 1 inch long.

2. Design a wooden beam of constant strength supported at the ends for a span of 6 feet with a load of 600 pounds in the middle and a distributed load of 120 pounds per foot. The allowable fiber stress is 1000 pounds per square inch and the beam sections square. The allowable shearing stress is 100 pounds per square inch and the bearing stress 120 pounds per square inch.

3. Solve Problem 2 if the concentrated load is 4 feet from one end.

94. Deflection of Beams of Constant Strength.— The problem of finding the deflection of a beam of constant strength differs from that of a uniform section in that the moment of inertia is no longer constant but is a function of x . In beams of constant strength and rectangular section,

$$M = \frac{2sI}{d},$$

where s is constant throughout the length and d may be constant or variable. In the following discussions when the depth is constant we will represent it by the capital D , and when the breadth is constant we will use the capital B . This will enable

us more readily to distinguish between constants and variables in integrating.

95. Cantilever of Constant Depth with Load on the End. —

$$EI \frac{d^2y}{dx^2} = - \frac{2sI}{D}. \tag{1}$$

Dividing by I :

$$E \frac{d^2y}{dx^2} = - \frac{2s}{D}, \tag{2}$$

where E , s , and D are constants. We will consider the beam as fixed at the right end.

$$E \frac{dy}{dx} = - \frac{2sx}{D} + \left(C_1 = \frac{2sl}{D} \right); \tag{3}$$

$$E \frac{dy}{dx} = \frac{2s}{D} (l - x). \tag{4}$$

$$Ey = - \frac{s}{D} (l - x)^2 + (C_2 = 0). \tag{5}$$

$$y_{\max} = - \frac{sl^2}{ED}. \tag{6}$$

We have now the maximum deflection in terms of s and D . We will calculate it in terms of the dimensions at the wall. If I_m is the maximum value of the moment of inertia (at the wall):

$$s = \frac{PDI}{2I_m}$$

$$y_{\max} = - \frac{PDI^3}{2EDI_m} = - \frac{Pl^3}{2EI_m}, \tag{7}$$

$$y = - \frac{Pl}{2EI_m} (l - x)^2. \tag{8}$$

From equation (7) we see that the deflection of a cantilever of constant strength and constant depth, due to a load on the free end, is one and one-half times as great as the deflection of a cantilever of uniform section having the same maximum dimensions.

96. Cantilever of Constant Breadth with Load on the End. —

$$E \frac{d^2y}{dx^2} = - \frac{2s}{d}, \tag{1}$$

where d is a variable.

$$d^2 = \frac{6Px}{sB},$$

where B is the constant breadth. Equation (1) becomes:

$$E \frac{d^2y}{dx^2} = -2s \sqrt{\frac{sB}{6Px}}. \quad (2)$$

$$Ey = 4s \sqrt{\frac{sB}{6P}} \left(l^{\frac{3}{2}}x - \frac{2}{3}x^{\frac{3}{2}} - \frac{l^{\frac{3}{2}}}{3} \right) \quad (3)$$

$$Ey_{\max} = -\frac{4sl^{\frac{3}{2}}}{3} \sqrt{\frac{sB}{6P}}. \quad (4)$$

Substituting the value of s in terms of the breadth and depth at the wall:

$$y_{\max} = -\frac{2Pl^3}{3EI_m}, \quad (5)$$

which is twice the deflection of a cantilever of uniform section with the same maximum dimensions.

PROBLEMS.

1. Find the expression for the deflection at the middle for a beam of constant strength and constant depth due to a load at the middle of the span, the beam being supported at the ends.

$$\text{Ans. } -\frac{Pl^3}{32EI_m}.$$

2. Find the expression for the deflection of a beam of constant strength and constant breadth, supported at the ends with a load at the middle.

$$\text{Ans. } y_{\max} = -\frac{Pl^3}{24EI_m}.$$

3. In the case of a cantilever of constant depth with a load of w pounds per inch uniformly distributed, what is the deflection at the free end?

$$\text{Ans. } -\frac{wl^4}{4EI_m}.$$

4. Solve the case of a cantilever of constant strength and constant breadth with a uniformly distributed load.

$$\text{Ans. } Ey = -2s \sqrt{\frac{sB}{3w}} \left(x \log \frac{x}{l} - x + l \right).$$

$$y_{\max} = -\frac{wl^4}{2EI_m} = -\frac{Wl^3}{2EI_m}.$$

5. How do the deflections at the ends in Problems 3 and 4 compare with those in uniform beams?

6. Find the expression for the deflection at the end of a cantilever of constant strength, with sections similar rectangles, due to a load at the free end.

97. Cast-iron Beams.—Parts of machines are frequently made of cast iron. Cast iron differs from most structural materials* in that the ultimate strength in tension is much less than

* There is a greater difference in concrete.

in compression. A good sample of cast iron may have an ultimate tensile strength of 25,000 pounds per square inch and a compressive strength of as much as 100,000 pounds per square inch. Working stresses in cast-iron members subject to bending should be about 3000 pounds per square inch on the tension side, and may be 10,000 pounds per square inch on the compression side. The ultimate strength in compression being four times as much as in tension we would naturally expect that this ratio should hold in designing cast-iron beams; but owing to the fact that the neutral axis is shifted from the center of gravity of the cross section after the material passes the elastic limit, a lower ratio should be used.

The cast-iron beam of rectangular section in Problem 3, Article 56, showed a modulus of rupture of 44,000 pounds per square inch. The same bar in tension broke under 27,000 pounds per square inch, the shifting of the neutral axis and the deviation of the tension and compression stress-strain diagrams from straight lines accounting for this difference.

In order to use the material economically, cast-iron beams are generally made of sections which bring the center of gravity two or three times as far from the compression side as it is from the tension side. The corresponding stresses in the outer fibers bear approximately the same ratio.

PROBLEM.

1. A cast-iron beam 40 inches long is supported at the ends and carries a load at the middle. The section is that of Fig. 123. If the allowable fiber stress in tension is 3000 pounds per square inch and the allowable stress in compression is 10,000 pounds per square inch, what is the safe load with the flange at the top and also with the flange at the bottom?

Ans. 595 pounds, 1390 pounds.

The above problem has been solved with the assumption that the stress-strain diagram is a straight line and that the modulus of elasticity is the same in compression and in tension. How near these assumptions are true may be seen from Fig. 124. This figure represents the stress-strain diagrams for cast iron from the same heat, tested at the Watertown Arsenal. (Tests of Metals, 885, pages 475-490.) The tension curve is drawn from the mean of four tests and the compression curve from the mean of twelve tests. (Only a part of the compression curve is drawn. The ultimate strength of this iron in compression was apparently 52,000 pounds per square inch for bars 12 inches long and 1 square inch cross section. As

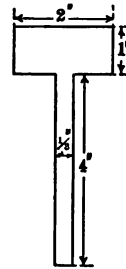

Fig. 123.

the bars bent considerably before failure the actual compressive stress was much above this figure.)

The compressive diagram is a straight line up to 13,000 pounds per square inch. The tension diagram is slightly curved in the neighborhood of 3000 pounds. The modulus of elasticity in tension is slightly greater than the modulus in compression. The curves are so close together, however, that little error is made in using the above assumptions for tensile stresses of 3000 pounds with compressive stresses of 10,000 pounds.

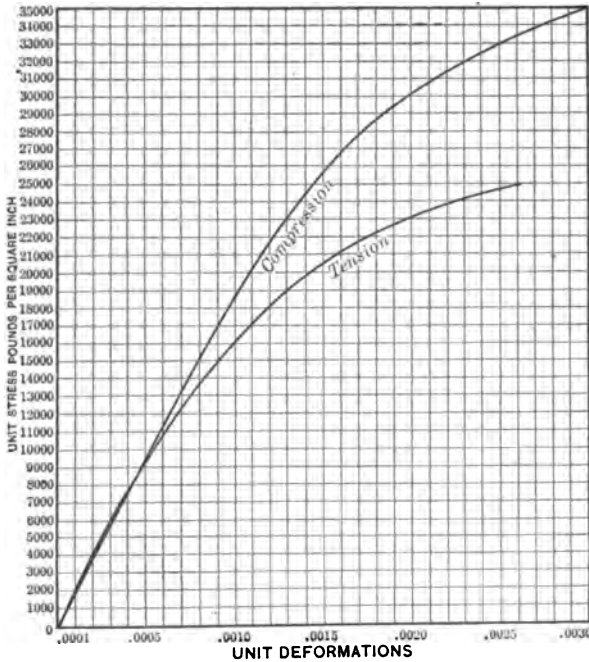

Fig. 124. — Stress-strain Diagrams for Cast Iron.

When it comes to computing the unit stress at rupture, the case is different.

Let us consider a beam of rectangular section 1 inch wide with the outer fibers in the tension side 1 inch from the neutral axis and determine the depth of the compression side in order that the total compression shall equal the total tension when the elongation in the outer fibers in tension is 0.0025. The unit stress in these outer fibers from the curve is found to be 24,800 pounds per square inch. The total tension is obtained from the average ordinate of the curve. To get this average ordinate we divide the area measured by a planimeter by the length of the base. Or each ordinate may be regarded as the mean altitude of a strip of width equal to the distance between the ordinates. For instance, the ordinate which corresponds to the unit elongation of 0.001 is 16,100 pounds. This may be taken as the altitude of a strip of width 0.0001 extending from elongation 0.00095 to 0.00105. The sum of the ordinates

from 0.0001 to 0.0024 inclusive multiplied by the width of the interval will give the area from 0.00005 to 0.00245. The half intervals from 0 to 0.00005 and from 0.00245 to 0.00250 may be computed separately. Calling the interval between the ordinates unity to avoid decimals,

Area from 0 to 0.5	131
Area from 0.5 to 24.5 (Sum of 24 ordinates)	398,650
Area from 24.5 to 25	12,350
Total	411,131
Dividing by 25 Mean stress	16,445

If the width of the section is b and the height from the neutral surface is v_2 , the total tension is the product of the area bv_2 multiplied by the mean unit stress.

The total compression below the neutral surface must equal the total tension above. If the width is unity as in Fig. 125, the total compression is the average compressive stress multiplied by v_1 . But this product is the area of the compression diagram. It is only necessary, then, to find the ordinate which forms the right boundary of an area below the compression curve which is 411,131 units. The curve being a straight line to the deformation 0.00075, at which the unit stress is 14,300 pounds, we get this much of the area from the triangle.

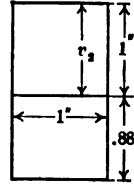

Fig. 125. — Neutral Axis in Rectangular Cast Iron Section.

Area from 0 to 7.5 (taken as a triangle)	53,625
Area from 7.5 to 20.5 (Sum of 13 ordinates)	309,570
Total to 20.5	363,195
Ordinate at 21	30,850
Total to 21.5	394,045
Area required beyond 21.5	17,086
Total	411,131

Dividing 17,086 by 31,400 which is approximately the mean ordinate for the remainder of the area, we get 0.56.

$$21.5 + 0.56 = 22.06.$$

The compression depth, v_1 , is to the tension depth, v_2 , as 22.06 to 25. In other words, v_1 is practically 88 per cent of v_2 as shown in Fig. 125.

The moment of the total tension is obtained by multiplying each ordinate by its abscissa and adding the products. The result for a section above the neutral axis 1 inch square is 10,506 inch pounds. In the same way the moment of the compression area for a section below the neutral axis 1 inch wide and 0.88 inch deep is 9541 inch pounds. The total moment of the section is 20,047 inch pounds.

If we take a beam 1 inch wide and 1.88 inches deep and compute the maximum fiber stress from $s = \frac{Mv}{I}$, we get 34,000 pounds per square inch for the value of s corresponding to this moment instead of 24,800 pounds in tension and 31,400 pounds in compression. Fig. 126 shows the difference between a cast-iron beam of rectangular section having an ultimate tensile stress in the

outer fibers of 24,800 pounds per square inch (II) and a similar beam subjected to the same moment but with a straight line curve (I). These figures show the shifting of the neutral axis and show why the modulus of rupture does not agree with the maximum tensile strength.

Fig. 127 shows the stress distribution in a cast-iron T section with a relatively thick stem with the flange in tension.

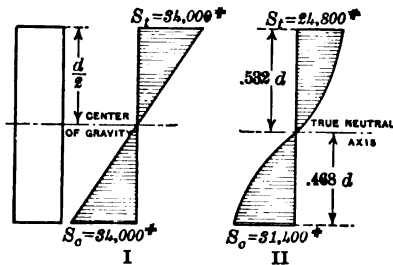

Fig. 126. — Stress Distribution in a Cast Iron Section.

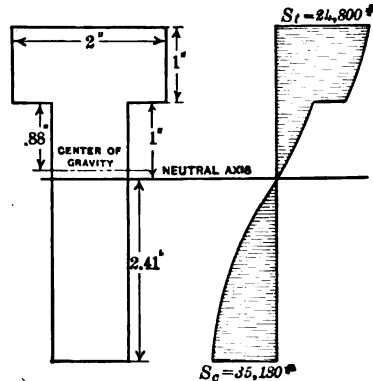

Fig. 127.

In the case of cast-iron beams, where it is not practicable to test full-size members, it is advisable to make small beams of similar sections and test them. The strength of the large beam of *similar cross section* and the same length may be computed from the cube of the like dimensions.

98. Beams of Two or More Materials. — Beams are frequently made of two or more materials having different moduli of elasticity. The most common cases are beams made by bolting iron or steel plates to wooden beams, and reinforced concrete beams, in which steel rods are embedded in the concrete in the tension side.

Fig. 128 represents a beam made by bolting a steel plate to one side of a wooden beam. In calculating the section modulus we must remember that the modulus of elasticity in the wood is less than that in the steel, and that with a given deformation the unit stress in the two materials is proportional to their respective moduli. If the modulus of the steel is 30,000,000 and that of the wood is 1,500,000 the stress in the steel corresponding to a given unit elongation is 20 times as great as the stress in the wood. To find the neutral axis in this case we may use Fig. 128, II, regarding the steel area $ABCD$ as having a density 20, while the wood area has a density unity; or we may use Fig. 128, III,

regarding the steel area $ABCD$ as replaced by the wood area $EFGH$ twenty times as wide as the steel and of the same thickness.

PROBLEMS.

(Use E for steel, 20 times E for wood in these problems.)

1. A 6-inch by 8-inch wooden beam has a 6-inch by $\frac{1}{2}$ -inch steel plate fastened to the lower side. Find the neutral axis.

Ans. 1.64 inches from the bottom of the wood.

2. A 4-inch by 4-inch wooden beam has a 4-inch by $\frac{1}{2}$ -inch steel plate on the lower side and a 1-inch by 1-inch bar embedded in the upper side, the top of the bar being flush with the top of the timber. Find the neutral axis.

Ans. 1.18 inches from the bottom of the timber.

To calculate the stress in beams of this kind we may use the timber as the unit and regard the steel as expanded into the equivalent amount of wood as in Fig. 128, III. We may determine

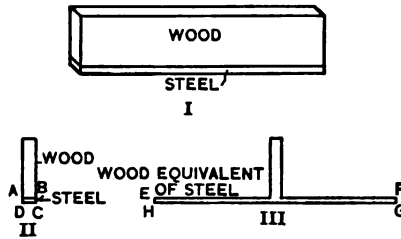

Fig. 128.

the section modulus on this assumption and find the stress in the outer fibers. To find the stress for steel at a given point, multiply the stress calculated for wood by the ratio of the moduli of elasticity.

PROBLEMS.

3. In Problem 1, what is the equivalent moment of inertia of the section?

Ans. 738.5 inches⁴.

4. In Problem 3, the beam is subjected to a bending moment of 120,000 inch pounds. What is the maximum fiber stress in the steel and in the wood?

Ans. 1033 pounds per square inch in the wood.

6955 pounds per square inch in the steel.

5. In Problem 2, the beam is 10 feet long and supported at the ends. What is the greatest load which may be applied at the middle if the allowable unit stress in the steel is 15,000 pounds per square inch?

Ans. 1938 pounds.

6. A beam 10 feet long, supported at the ends and loaded at the middle, is made of two $\frac{1}{2}$ -inch by 8-inch plates of steel bolted to the vertical faces of a 6-inch by 8-inch wooden beam. If the allowable unit stress in the steel is 15,000 pounds and in the wood is 1000 pounds, what is the maximum safe load?

7. In a beam of the form of Problem 6 what should be the ratio of the depth of the wooden beam to that of the steel plates if both reach their allowable load at the same time?

99. Reinforced Concrete Beams.— Reinforced concrete represents another form of combination beam. A reinforced concrete beam has steel rods embedded in the concrete near the surface in the tension side. Sometimes both tension and compression sides are reinforced. These rods may be ordinary round or square steel bars. Usually they are corrugated in some way or made of cable or twisted square bar so that they will not slip even if the grip of the concrete should be weakened. Many designers use steel with a high yield point, 50,000 pounds per square inch or more. Such steel may safely be subjected to stresses of 18,000 pounds per square inch, provided it has not been subjected to rough treatment causing short bends or kinks.

Fig. 129 represents a portion of a reinforced concrete beam 8 inches by 11 inches in cross section. The reinforcement consists

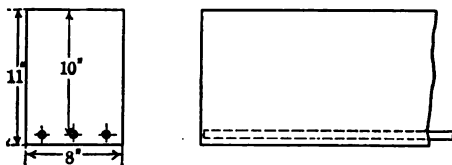

Fig. 129.

of three rods with centers 1 inch from the bottom of the beam. The photograph, Fig. 119, shows a beam of this size after failure.

In working out the theory of concrete beams, it is customary to regard the steel as taking all the tension. If the unit stresses are kept low, the concrete on the tension side of the neutral axis does exert some tensile stress, but at loads of less than one third of the ultimate strength of the beam fine cracks form in the tension side and tests show that the steel takes practically all the tension at larger loads.

We are accustomed to speak of the per cent of reinforcement. This is obtained by dividing the area of the steel by the area of the beam section above the center of the steel. In Fig. 129 the beam is regarded as an 8-inch by 10-inch section; the inch of concrete is considered as simply protecting the steel. If the rods in Fig. 129 are $\frac{3}{8}$ inch round, the reinforcement is 1.15 per cent.

More or less elaborate formulas have been proposed for reinforced concrete beams. Any formula depends upon the form of the compression curve of the concrete. This curve varies greatly with the material, the proportions, the care in mixing, the age, and the stresses to which it has been subjected. The modulus of elasticity of concrete is lowered greatly by slight overloads. For these reasons there is little use for great refinement of calculation unless you have good experimental data in regard to the concrete which you are using.

The portion of the section above the neutral axis is in compression. The line *OF*, Fig. 130, represents the compression curve. If the stresses are small, this curve is a straight line. If they are large, it is somewhat curved, as in Fig. 85. (Fig. 10 is the compression curve of one sample of concrete). If the section of the beam is rectangular above the neutral axis the total compression may be represented by the triangular area *OFC*. If the angle of bend in unit length of the beam is $d\theta$, the unit stress in the top fibers at a distance v_2 from the neutral surface is

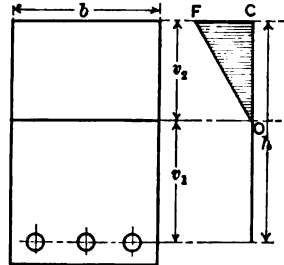

Fig. 130. — Distribution of Stress in a Reinforced Concrete Beam.

$$v_2 E_c d\theta,$$

where E_c is the modulus of the concrete in compression. The total stress in a section of width b is given by

$$\text{Total compression in concrete} = \frac{bv_2^2 E_c d\theta}{2}.$$

If we take v_1 as the distance from the neutral surface to the center of the steel, the total stress in the steel is given by

$$\text{Total tension in steel} = A_s v_1 E_s d\theta,$$

where A_s is the steel area and E_s its modulus in tension.

Since the total compression in the concrete equals the total tension in the steel,

$$\frac{bv_2^2 E_c}{2} = A_s v_1 E_s, \quad v_2^2 = 2v_1 \frac{A E_s}{b E_c}. \tag{1}$$

Also $v_2 + v_1 = h,$ (2)

where h is the depth from the top of the beam to the center of

reinforcement. These equations enable us to locate the neutral axis in terms of h for any per cent of reinforcement.

It must be remembered that the theory above is on the simple assumption that the concrete curve for the stresses used is practically a straight line.

PROBLEMS.

1. If the modulus of elasticity of the steel is fifteen times as great as that of the concrete and the area of the steel is 1 per cent of the area bh , find v_2 in terms of h . *Ans.* $v_2 = 0.42 h$.

2. If the modulus of elasticity of the steel is 30,000,000, and that of the concrete 2,000,000, locate the neutral axis for reinforcements of 1 per cent, 1.2 per cent, 1.5 per cent. *Ans.* $v_1 = 0.58 h, 0.55 h, 0.52 h$.

3. In Problem 1 what is the *average* unit compressive stress in the concrete if the unit tensile stress in the steel is 10,000 pounds per square inch, and what is the unit compressive stress in the outer fibers?

Ans. 238, 476 pounds per square inch.

4. In Problem 2 what is the compressive stress in the top fibers of the concrete when the unit tensile stress in the steel is 12,000 pounds per square inch? *Ans.* 571, 640, 750 pounds per square inch.

The unit stresses in Problem 4 are too high to be allowed. The results show that it is not *economical* to use too great a percentage of steel, for with large percentage of steel the concrete reaches its allowed value in compression while the stress in the steel is still relatively small.

PROBLEMS.

5. With one-half of 1 per cent reinforcement, and with the modulus of steel fifteen times as great as that of concrete, what is the maximum compressive stress in the concrete when the tensile stress in the steel is 12,000 pounds per square inch? *Ans.* 375 pounds per square inch.

6. With 0.8 per cent of reinforcement and the modulus of the steel fifteen times that of the concrete, what is the unit stress in the steel when the maximum stress in the concrete is 400 pounds per square inch?

100. Resisting Moment in Reinforced Concrete. — The compressive stress in the concrete above the neutral axis and the tensile stress in the steel form a couple. The moment of this couple is the product of either total stress multiplied by the distance between their resultants. The resultant stress in the steel is *taken* as applied at the center of the steel section. The resultant of the compressive stress is at the center of gravity of the triangle OFC , Fig. 130. The moment arm is

$$v_1 + \frac{2}{3} v_2,$$

provided the compression diagram is a straight line. If the

compression diagram is curved, the moment arm is slightly smaller. Calculations from the compression curves of Fig. 10 show that the center of gravity of the area is $0.62 v_2$ at the ultimate stress and $0.64 v_2$ when the stress is carried to 400 pounds per square inch. There is, therefore, little error in assuming that the resultant of the compressive stress is $0.67 v_2$ above the neutral axis in all cases.

PROBLEMS.

1. Using 1 per cent reinforcement and E_s fifteen times E_c , what is the effective resisting-moment arm? *Ans.* $0.86 h$.
2. In Problem 1, if the unit stress in the steel is 10,000 pounds per square inch, what is the resisting moment? *Ans.* $86 bh^2$.
3. If the beam in Problem 2 is 8 inches wide and 10 inches deep from top to center of reinforcement, what is the resisting moment? *Ans.* 68,800 inch pounds.
4. In Problem 3 the beam is 10 feet long and supported at the ends. What load at the middle will give the required moment, computing the concrete at 150 pounds per cubic foot and neglecting the weight of the steel and of the concrete below the reinforcement? *Ans.* 1877 pounds.

To get the resisting moment of a reinforced concrete beam, we compute the moment of the couple of which the total tension is one force and the total compression the other force. The total tension in the steel is easily computed by multiplying the area by the allowable unit stress. The moment arm must be less than h ; experiments and theory show that it is about $0.8 h$. To get the resisting moment, then, we multiply the area of the steel by its allowable unit stress and multiply the total stress thus obtained by 0.8 of the distance from the center of the steel to the top of the beam. This gives a simple method of *approximate calculation* for a beam of *rectangular section*. We must not apply this, however, to beams with too great a per cent of reinforcement, as these will fail by compression of the concrete before the steel reaches a considerable stress. The allowable amount of reinforcement may be computed for beams of rectangular section by the methods of the preceding article, or may be determined from the *results of tests* of large concrete beams.

PROBLEMS.

5. Assuming that the point of application of the resultant compression is 0.8 of the depth from the steel and that the allowable unit stress in the steel is 15,000 pounds, find the total safe load at the middle of an 8-inch by 10-inch beam 10 feet long, supported at the ends, with a reinforcement of 1 per cent. *Ans.* 3200 pounds if the weight of the beam is neglected.

6. What must be the approximate depth of a rectangular beam 12 inches wide and 15 feet long, supported at the ends, to carry a load of 600 pounds per foot, including its own weight, if the reinforcement is 0.9 per cent and the allowable stress 12,000 pounds per square inch?

101. Resultant Tensile Stress. — In Article 86 we learned that the combined effect of a tensile and shearing stress produced a resultant tensile stress at an angle with the direct tension. The tensile strength of concrete is small relatively to the compressive strength and is the same in all directions. A concrete beam is likely to fail in tension along a line perpendicular to the direction of the maximum resultant tensile stress. The photograph, Fig. 119, shows a failure of this kind. A concrete beam should have some reinforcement along the direction of the resultant

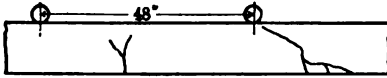

Fig. 131. — Failure of a Reinforced Concrete Beam.

tensile stress as well as longitudinally along the tension side. Fig. 131 is a diagram showing the cracks at failure in a beam similar to Fig. 119 and loaded in the same way.

Notice that the cracks in the middle third where there is no shear run nearly vertical, while the crack outside of the load is inclined. This beam and the one in Fig. 119 had longitudinal reinforcement only. Unless the shear is relatively small, a concrete beam should have additional reinforcement arranged as shown in Fig. 132. These inclined bars are called *shear bars*. They may be rigidly attached to the tension bars or may be separate.

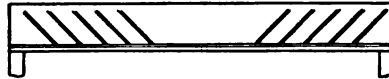

Fig. 132. — Shear Bars for Reinforced Concrete.

When a beam is continuous over several supports, it follows, of course, that the reinforcement must be placed near the top in the portion where the moment is negative.

Lewis P. McGilvary
Elect. Eng. 1913

CHAPTER XI.

BENDING COMBINED WITH TENSION OR COMPRESSION.

102. Transverse and Longitudinal Loading.— It often happens that a beam is subjected to a direct tension or compression in the direction of its length and a transverse force producing a bending moment. The unit stress at any point in a given section is the sum of the direct stress and the bending stress at that point. For example, suppose a 4-inch by 4-inch post stands vertical and supports a load of 4000 pounds at the top. The direct compressive stress is 250 pounds per square inch. Suppose this post is fixed at the bottom (Fig. 133), and that a horizontal push of 200 pounds is applied 2 feet from the bot-

tom. This transverse force produces a tensile stress of 450 pounds per square inch in the outer fibers at the bottom on the side of the push and a compressive stress of the same magnitude in the opposite side. The resultant stress is 700 pounds per square inch in the one side and 200 pounds per square inch in the other. Fig. 133, IV, shows the distribution of the stress, compression being represented by the vertical distance downward. In Fig. 133,

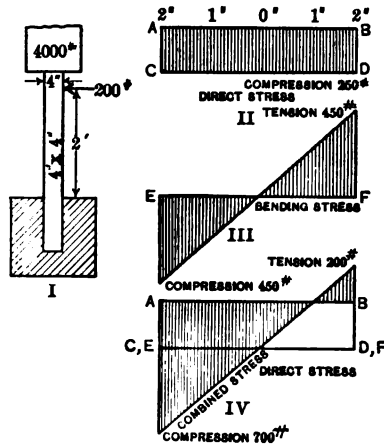

Fig. 133. — Post with Compression and Bending.

II, we have the compression alone due to the direct load of 4000 pounds. In Fig. 133, III, we have the stress due to bending; it is 450 pounds compression on the left side and 450 pounds tension on the right. At the middle of the section it is zero. In Fig. 133, IV, the two stresses are combined. The line *EF*, which is the zero line for the bending stress, is placed on the line *CD*,

representing the compressive stress in II. At a point $\frac{1}{2}$ inch from the right of the diagram the resultant stress is 0.

The resultant stress, being the sum of the direct and the bending stress, is given by the expression:

$$\text{Unit stress} = \frac{P}{A} + \frac{Mv}{I}, \quad \text{Formula XXI.}$$

where P is the total load parallel to the length of the beam and M is the bending moment from any source whatever. Since v has the positive sign on one side of the neutral axis and the negative sign on the other side, the second term may be positive or negative, according to the position.

PROBLEMS.

1. A wooden post 6 inches square and 5 feet high is fixed at the lower end and carries a load of 7200 pounds at the top. A horizontal push of 180 pounds is exerted upon the north side of the post 50 inches from the bottom. Find the maximum tensile and compressive stress at the bottom.

Ans. 50 pounds per square inch tension on the north side;

450 pounds per square inch compression on the south side.

2. A wooden post 6 inches by 8 inches is placed vertical, with the 8-inch faces in the meridian. The post projects 6 feet from the ground. A load of 12,000 pounds is placed on the top and a horizontal push of 400 pounds directed south is applied to the north face 1 foot from the top. Find (a) the unit stress at the bottom on the north side; (b) the unit stress at the bottom on the south side; (c) the location of the line of zero stress in the bottom section; (d) the position of a section having zero stress on the north side.

Ans. (a) 125 pounds tension; (b) 625 pounds compression; (c) $1\frac{1}{2}$ inches from the north side; (d) 4 feet 4 inches from the top.

3. A 2-inch solid shaft supported on bearings 4 feet apart carries a load of 400 pounds at the middle and is subjected to a horizontal compression of 8000 pounds parallel to its length. Find the maximum and minimum unit stress, neglecting the weight of the shaft.

Ans. 8662 pounds compression; 3570 pounds tension.

4. A concrete wall 10 feet high and 1 foot thick is subjected to a horizontal water pressure which varies as the depth and is 62.4 pounds per square foot at a depth of 1 foot. The concrete weighs 150 pounds per cubic foot. Find the maximum tensile and compressive stress at the bottom.

103. **Eccentric Loading.** — Let a rigid bar G , Fig. 134, be supported by three equal and symmetrically placed rubber bands (or springs) suspended from a fixed horizontal support. Each of the bands will be stretched equally and the bar will hang in a horizontal position (Fig. 134, I). Now attach a load P at the middle of the bar. Each rubber band will receive the

same elongation and the bar will remain horizontal in the position of Fig. 134, II. If the load P be moved to the right, as in Fig. 134, III, the middle band will receive the same elongation as in the preceding case, while the left band will be elongated less and the right band more. If we place the load still farther to the

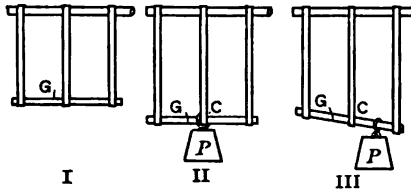

Fig. 134. — Eccentric Loading of Rubber Bands.

right, we finally reach a position where the left end is elevated above the position which it occupied before the load was applied, so that finally no load whatever comes on the left band. If instead of the rubber bands, we use helical springs of relatively large cross section, which are able to resist compression as well as tension, we may secure compressive stress in the spring which is on the side of the center away from the load.

Instead of the rubber bands we might use a continuous body, as a sheet of rubber or metal. If such a sheet is fastened to a rigid body at the top and bottom and a load is applied considerably to one side of the center, there will be an elongation on that side and a shortening or buckling on the other. A similar result obtains when a compressive load is applied to a body. Fig. 135 shows a block of soft rubber with the load central, and Fig. 135, II, shows the effect of moving this load a little to one side.

If we consider the bar G of Fig. 134, III, we see that the effect of the eccentric load is a translation downwards, of the same magnitude as that due to the central load in II, together with a rotation about the bottom of the middle band as an axis. Taking moments about this point C , we find that equilibrium occurs when the moment of the load P with respect to C is equal to the moment of the excess of tension in the right band plus the

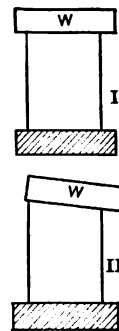

Fig. 135. — Compression with Direct and with Eccentric Loading.

moment of the deficiency of tension in the left band. Suppose that the bands are 4 inches apart, and that a load of 1 pound stretches the bands 0.4 inch. One pound will stretch a single band 1.2 inches. Now move the load of 1 pound 2 inches to the right of the middle. The moment of the load is 2 inch pounds, which is balanced by a force of 0.5 pound at 4 inches. The tension in the right band is 0.25 pound more than that in the middle, and the tension in the left band is 0.25 pound less. If the load is moved more than 3 inches from the middle, the tension in the left band becomes less than it was before the load was applied.

We learned in Mechanics* that a force along any line may be replaced by an equal force along any parallel line and a couple whose moment is the product of the force multiplied by the distance between the lines. In Fig. 136 the body is sub-

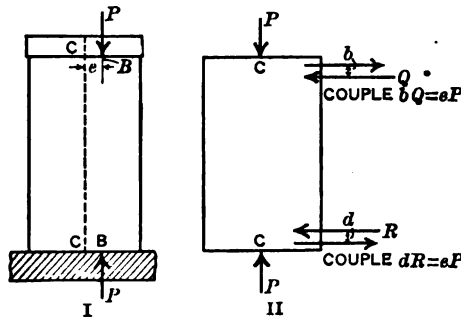

Fig. 136. — Block with Eccentric Loading.

jected to a compressive force of P pounds along a line through the point B . The force is parallel to the axis CC . The distance of the line of force, BB , from the axis is called the *eccentricity* of the load and is represented by the letter e . The force P at B may be replaced by a force P at C and a couple of moment eP tending to rotate the top of the block in a clockwise direction. The two equal and oppositely directed forces which comprise this couple may be regarded as having any magnitude, direction, and position, provided only that the product of the magnitude of either force multiplied by the distance between them is equal to moment eP . We may consider the couple at the top as made of

* Hoskins' Theoretical Mechanics, Art. 94; Maurer's Technical Mechanics, Art. 31.

two horizontal forces Q at a distance b apart, provided $bQ = eP$. In the same way, the opposite couple at the bottom may be made of two horizontal forces R at a distance d apart, with a moment $dR = eP$, tending to produce counterclockwise rotation. It is evident, then, that the portion of the body between the lower force Q and the upper force R is subjected to a bending moment eP and a direct load P at C . The forces R and Q may be regarded as indefinitely large and the distances b and d indefinitely small, so that the *entire block* may be considered as subjected to the bending moment.

It will be noticed that the force P at the top of Fig. 136 is really the resultant of a set of forces distributed over the entire top, and varying uniformly from left to right. The cap at the top and the support at the bottom are supposed to be relatively very rigid. If the load is applied to a small area instead of over the entire end of the body, the unit stress at some points near the end will be larger than that indicated by the theory. Near the middle of the length, the stress will be practically the same as if the force were applied by means of a rigid cap and support.

Fig. 137 shows large eccentricity, the resultant load lying entirely outside of the section. Here the existence of bending

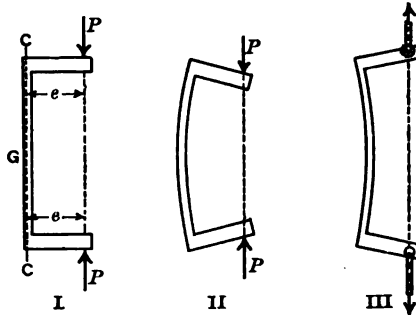

Fig. 137. — Large Eccentricity.

and direct stress together is almost self-evident. Consider the portion above any section G . Resolving vertically, the vertical reaction at the section is equal to the load P at the top. Taking moments about an axis perpendicular to the plane of the paper through the center of the section G , the resisting moment of the section must equal the moment eP . Fig. 137, II, shows the effect of compression and Fig. 137, III, the effect of tension.

Compression combined with bending is shown in Fig. 138. The forces P are applied to the wrenches by the screw clamp. The wrenches as cantilevers transmit the bending moments and direct compression to the bar. The experiment may easily be performed by two wrenches and a steel or wooden bar, the force being applied to the wrenches by hand. The bar will bend as in Fig. 137, II, if the forces are towards each other, and as in Fig. 137, III, if the forces are from each other.

The clamp of Fig. 138 is subjected to *tension* and bending. The eccentricity is the distance from the center of the screw to



Fig. 138.

the center of gravity of any section. In a hook the load line joins the shank with the point which is immediately below it when loaded. This point is, of course, the point in concave portion which is farthest from the shank. The eccentricity is the distance of this load line from the center of gravity of the section.

BENDING WITH TENSION OR COMPRESSION 175

PROBLEMS.

1. A 4-inch by 6-inch short block is subjected to a compressive load of 6000 pounds, the line of the resultant load being $\frac{1}{2}$ inch from the axis of the block in the plane parallel to the 6-inch faces which passes through the axis. Find the maximum compressive stress and the minimum stress.
Ans. Maximum, 375 pounds per square inch;
 Minimum, 125 pounds per square inch compression.
2. In Problem 1 solve for the case when the load is 1 inch from the axis.
Ans. 500 pounds per square inch, 0.
3. A solid circular rod 1 inch in diameter is subjected to a pull of 4000 pounds. What is maximum and minimum unit stress when the line of pull is 0.1 inch from the axis?
Ans. 9167 pounds tension, 1019 pounds tension.
4. Solve Problem 3 if the line of pull is 0.2 inch from the axis.
Ans. 13,241 pounds tension, 3055 pounds compression.
5. A block b wide and d thick, of rectangular section, has the load so placed that the unit stress in the outer fibers on one side is zero. If the line of load is in the plane of symmetry parallel to the faces of ~~breadth~~ ^{depth} d , what is the eccentricity?
Ans. $\frac{d}{6}$.
6. What eccentricity in a solid circular section of radius a will make the unit stress on one side zero?
Ans. $e = \frac{a}{4}$.
7. A hollow circular cylinder of outside radius a and inside radius b is so loaded that the unit stress on one side is zero. What is the eccentricity?
Ans. $e = \frac{a^2 + b^2}{4a}$.
8. In a hook of circular section the distance from the center of the section to the line of the load is 3 inches. The load is 1000 pounds and the diameter of the section is 2 inches. What is the maximum tensile and compressive stress?
Ans. 4138 pounds tension, 3501 pounds compression.
9. A hook of circular section has the center of the section 4 inches from the line of the load. What must be its diameter to carry a load of 6000 pounds if the unit stress in tension shall not exceed 10,000 pounds per square inch?
Ans. 2.99 inches.
10. What is the minimum diameter of the shank in Problem 9, if the allowable unit stress is 6000 pounds per square inch?

The hooks of Problems 8 and 9 have circular sections and the unit stress on the tension side is greater than on the compression side. It is better to make the hook section of the form of Fig. 139, I, so that the tensile stress and compressive stress are about equal.

In the case of cast-iron hooks, since the allowable compressive stress is about three times as great as the allowable tensile stress, it is customary to use a modified T section (Fig. 139, II), which will make the distance from the neutral axis to the outer fibers in compression much larger than the distance to the tension side.

PROBLEMS.

11. The section of a steel hook at the maximum distance from the load line consists of two semicircles with centers 1.5 inches apart joined by two straight lines. The circle nearest the load line is 1 inch in diameter and the other is 0.8 inch in diameter. The load line passes 1.5 inches from the center of the larger circle. Calculate the maximum compressive stress when the maximum tensile stress is 6000 pounds per square inch.

12. A post 6 inches square and 5 feet high with two faces in the meridian carries a load of 1800 pounds 0.5 inch west of the middle on the top, and is subjected to a horizontal push of 72 pounds from west toward east applied at the top. What is the unit stress at the bottom on the east and west sides?

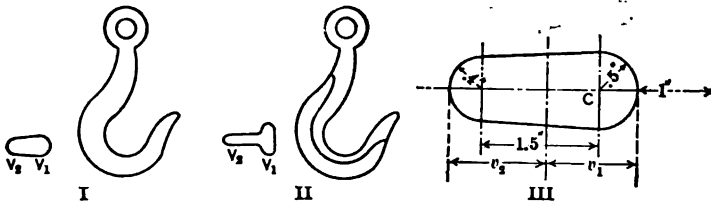

Fig. 139.

104. **Maximum Eccentricity without Reversing Stress.** — A brick pier laid in lime mortar has practically no tensile strength, and the tensile strength of masonry laid in cement is not reliable. For this reason the load on a masonry pier should always be placed so that the stress over the *entire section* shall be *compressive*. Problem 5 of Article 103 showed that a load on a rectangular section at a distance from the center greater than one-sixth of the dimension of the section in this direction produces a negative stress in the outer fibers in the opposite side. For this reason it is a rule of architects and engineers that the *resultant load* shall *not fall outside of the middle third* in the case of rectangular columns or piers. From Problem 6 we see that, with round piers of solid section, the load must not lie outside of a circle whose diameter is one-fourth that of the pier.

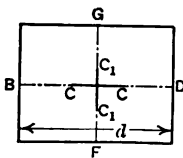

Fig. 140.

The statement that the load must lie inside the middle third means that if the load is on the line *BD*, Fig. 140, through the center of the rectangle parallel to the side *d*, it must lie in the middle third of this line. In the same way, if the load falls on the line *FG*, it must be between the points *C₁C₁* on this line. *CC* is one-third of the length *BD*.

PROBLEMS.

1. A 12-inch square brick pier carries a load of 7200 pounds. What is the unit stress when the resultant load lies 1 inch from the center of the section on a line through the center parallel to one side?

Ans. 75 pounds per square inch.

2. Solve Problem 1 when the load is 1 inch from the center on the diagonal of the square.

Ans. 85.3 pounds per square inch.

3. In Problem 1 how far may the load be placed from the center and not have tensile stress?

Ans. 2 inches.

4. In Problem 2 how far may the load be placed from the center and not reverse the stress?

Ans. 1.41 inch.

5. Compare the strength of a 12-inch by 12-inch pier with the load in the middle with that of a 12-inch by 16-inch pier with the load 2 inches from the middle on a line through the middle parallel to the long side.

Ans. The square pier is stronger in the ratio 21 : 16.

6. A square section of side b has the resultant load at a point C , the coordinates of which are (x, y) , Fig. 141, I. Show that when the unit stress at F is zero, the position of C satisfies the equation

$$6x + 6y = b.$$

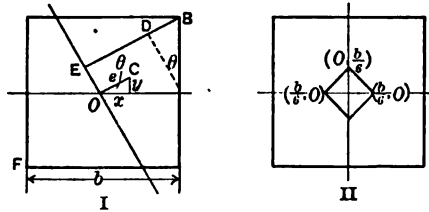

Fig. 141. — Maximum Eccentricity without Reversing Stress.

SUGGESTION. — The moment of inertia of a square section being the same for all axes through the center, the rotation will be about the axis OE perpendicular to OC . The distance of the extreme fibers at F from this axis is equal to EB .

The distance
$$EB = \frac{b}{2} (\cos \theta + \sin \theta).$$

$$I = \frac{b^4}{12}.$$

For zero stress at the corner, F ,

$$e (\cos \theta + \sin \theta) = \frac{b}{6}.$$

$$x + y = \frac{b}{6}.$$

105. Resultant Load not on a Principal Axis. — In all the problems of the preceding articles, the resultant load fell on one principal axis and rotation took place about the other principal axis. In the case of a round or square section, the moment of

inertia is the same for all axes through the center of gravity, and any such axis may be regarded as a principal axis. In other sections, when the load does not fall on a principal axis, the axis of rotation is not the line OE normal to OC , but is some line OG (Fig. 142) between OE and the axis for which I is a minimum.

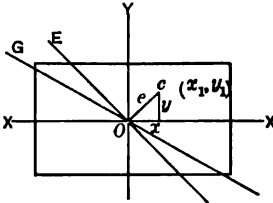

Fig. 142. — Eccentric Loading not on Principal Axis.

To solve the problem, we use the method of resolving the couple eP into components producing rotation about the two principal axes. These components for Fig. 142 are the couple Px tending to produce rotation about the Y axis and the couple Py tending to produce rotation about the X axis. The bending stress at any point x_1 in the section due to the moment Px is

$$\frac{Px x_1}{I_y},$$

where I_y is the moment of inertia with respect to the Y axis. In the same way the stress due to the couple Py may be calculated. The resultant stress due to bending is the sum of the two components.

EXAMPLE. — A rectangular block 12 inches long measured from east to west and 10 inches wide is subjected to a load of 3600 pounds 2 inches from the east edge and 2 inches from the north edge. Find the unit stress at each corner.

The bending stress at the north and south edges due to the couple of 10,800 inch pounds is 54 pounds per square inch. The bending stress at the east and west edges due to the couple of 14,400 inch pounds is 60 pounds per square inch. The direct compression is 30 pounds per square inch. The unit stresses at the corners are: 144 pounds compression at the northeast corner; 24 pounds compression at the northwest corner; 84 pounds tension at the southwest corner; 36 pounds compression at the southeast corner.

PROBLEMS.

1. A rectangle 8 inches long and 6 inches wide has a load of 1200 pounds applied $2\frac{1}{2}$ inches from one 8-inch side, and $3\frac{1}{2}$ inches from one 6-inch side. Find the unit stress at each corner.

Ans. 50, 25, 0, 25 pounds per square inch.

2. A rectangle of length b and height d has a load applied at a point whose coördinates are (x, y) with respect to axes through the center parallel to the sides. Show that if this point lies on a line whose intercepts are $\frac{b}{6}$ and $\frac{d}{6}$, the stress will be zero at the opposite corner.

BENDING WITH TENSION OR COMPRESSION 179

3. A rectangular post 6 inches by 10 inches has the 10-inch sides in the meridian. A load of 2400 pounds is applied 1 inch north and 1 inch east of the middle. A horizontal push of 200 pounds is 20 inches above the bottom directed south 30 degrees west, the line of the push passing through the center of the section. Find the unit stress at each corner at the bottom.

Ans. $\left\{ \begin{array}{l} 36.03 \text{ pounds at northeast corner.} \\ 22.69 \quad \text{ " " northwest " } \\ 43.97 \quad \text{ " " southwest " } \\ 57.31 \quad \text{ " " southeast " } \end{array} \right.$

Lewis P. McGilvary
Elect. Eng. 1916

CHAPTER XII.

COLUMNS.

106. **Definition.** — In the discussion in the preceding chapter, we said nothing in regard to the deflection of the body considered, and the effect of this deflection in changing the amount of eccentricity. In tension, the deflection is in the direction to diminish the eccentricity (Fig. 137, III). In compression, on the other hand, the deflection increases the eccentricity and consequently increases the unit stress (Fig. 137, II). A yard stick may be placed with one end on the floor and a compressive force applied with the hand to the other end. When the force reaches a certain amount, the stick suddenly bends and may deflect several inches from the straight line.

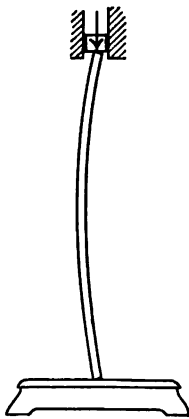

Fig. 143. — A Long Column.

When the force reaches a certain amount, the stick suddenly bends and may deflect several inches from the straight line. The original eccentricity of possibly 0.01 inch is increased to several inches and the unit stress may be sufficient to cause rupture. If the stick is placed with one end on a platform scale, as in Fig. 143, it is found that the load which produces a deflection of 2 inches is little, if any, greater than the load which causes a deflection of 1 inch. The resisting moment has been nearly doubled, but the external moment has likewise been doubled, owing to the increased length of the moment arm.

A compression member whose length is several times as great as its smallest transverse dimension is called a *column*. There is no definite ratio of length to diameter at which a compression member ceases to be a short block and becomes a column. We find, however, that when the ratio of length to the smallest transverse dimension is less than 10, the error made by neglecting the deflection is so small that it may ordinarily be neglected. Some engineers call a compression member of length less than 15 diameters a *short block* or pier and calculate it by the methods of the preceding chapter.

Columns may be vertical, as the intermediate posts of bridges, or horizontal, as the top chords of a bridge. The connecting rod of an engine is a column during the forward stroke. When a column is vertical, the only bending moment is that due to the eccentricity of the load and the deflection. When a column is horizontal or inclined, its own weight applied as a beam becomes an appreciable factor. The rafters supporting a roof act as columns and inclined beams.

A compression member of some length is frequently called a *strut*.

107. Column Theory. — Fig. 144 represents a vertical column with ends free to turn without friction about horizontal axes perpendicular to the plane of the paper. Fig. 144, I, represents the actual column with deflection somewhat exaggerated, and Fig. 144, II, shows the central axis of the column with all horizontal distances enlarged. The X axis is taken vertical and positive upward. (In all beam and column theory, the X axis is taken parallel to the original length.) The Y axis is horizontal and positive toward the left. We might take the column horizontal and neglect the bending moment due to its weight with the same result. The origin of coördinates is at the lower end at the center of the section.

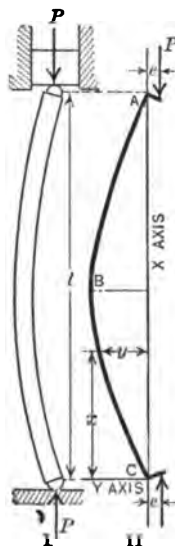

Fig. 144. — Column Deflection.

At a section at a distance x from the origin, the moment arm with respect to the center of gravity of the section is

$$y + e,$$

and the moment is

$$P(y + e).$$

Before writing the differential equation we must determine which sign to use with the moment expression. In Fig. 144, y is positive throughout the entire length of the column. The first derivative, $\frac{dy}{dx}$, is positive at the beginning and negative at the end; consequently the second derivative, $\frac{d^2y}{dx^2}$, is negative. In the same way, if the eccentricity were on the other side of the column so that the deflection would come on the right (negative),

$\frac{d^2y}{dx^2}$ would be always positive. The second derivative has the negative sign when y and e are positive and the positive sign when y and e are negative.

(The direction of e is from the line of force to the axis of the column.)

Since the signs of the second derivative and the moment arm are opposite, we write the differential equation

$$EI \frac{d^2y}{dx^2} = -P(y + e). \quad (1)$$

This equation may be written

$$\frac{d^2y}{dx^2} + \frac{Py}{EI} = -\frac{eP}{EI}, \quad (2)$$

which is a differential equation of the second order and first degree, with the right-hand member constant. The student familiar with Differential Equations will write it:

$$\left(D^2 + \frac{P}{EI}\right)y = -\frac{eP}{EI}. \quad (3)$$

The solution of (3) is:

$$y = C_1 \cos \sqrt{\frac{P}{EI}}x + C_2 \sin \sqrt{\frac{P}{EI}}x - e. \quad (4)$$

The student who is not familiar with Differential Equations may verify (4) by performing the inverse operations to get (2). A solution of a differential equation may always be proved by differentiating and eliminating the constants of integration. In this case, since the equation is of the second order requiring two integrations, we must differentiate twice. Differentiate (4) twice and multiply by $\frac{EI}{P}$. The result obtained added to the original equation (4) gives equation (2), which proves the solution.

To obtain the integration constants, the conditions are

$$y = 0 \text{ when } x = 0, \quad \text{and} \quad y = 0 \text{ when } x = l.$$

From the first condition:

$$C_1 \cos 0 - e = 0;$$

$$C_1 = e;$$

$$y = e \cos \sqrt{\frac{P}{EI}}x + C_2 \sin \sqrt{\frac{P}{EI}}x - e. \quad (6)$$

Substituting the second condition in (6):

$$0 = e \cos \sqrt{\frac{P}{EI}} l + C_2 \sin \sqrt{\frac{P}{EI}} l - e; \quad (7)$$

$$\begin{aligned} C_2 &= \frac{e \left(1 - \cos \sqrt{\frac{P}{EI}} l\right)}{\sin \sqrt{\frac{P}{EI}} l} = \frac{e \sin^2 \sqrt{\frac{P}{EI}} \frac{l}{2}}{\sin \sqrt{\frac{P}{EI}} \frac{l}{2} \cos \sqrt{\frac{P}{EI}} \frac{l}{2}} \\ &= e \tan \sqrt{\frac{P}{EI}} \frac{l}{2}. \end{aligned} \quad (8)$$

$$y = e \left(\cos \sqrt{\frac{P}{EI}} x + \tan \sqrt{\frac{P}{EI}} \frac{l}{2} \sin \sqrt{\frac{P}{EI}} x - 1 \right). \quad (9)$$

Equation (9) gives the deflection at any point of a column with ends free to turn but not free to move laterally. It is a sine curve. To find the point of maximum deflection, differentiate and set the first derivative equal to zero and find that $x = \frac{l}{2}$ is the position required. We might have assumed, from the symmetry of the figure, that the maximum deflection is at the middle and used this instead of the second condition in getting the constant C_2 .

To get the maximum deflection at the middle:

$$\begin{aligned} y_{\max} &= e \left(\cos \sqrt{\frac{P}{EI}} \frac{l}{2} + \tan \sqrt{\frac{P}{EI}} \frac{l}{2} \sin \sqrt{\frac{P}{EI}} \frac{l}{2} - 1 \right); \\ y_{\max} &= e \sec \sqrt{\frac{P}{EI}} \frac{l}{2} \left(\cos^2 \sqrt{\frac{P}{EI}} \frac{l}{2} + \sin^2 \sqrt{\frac{P}{EI}} \frac{l}{2} \right) - e; \\ y_{\max} &= e \left(\sec \sqrt{\frac{P}{EI}} \frac{l}{2} - 1 \right); \quad \text{Formula XXII.} \end{aligned} \quad (10)$$

$$y_{\max} + e = e \sec \sqrt{\frac{P}{EI}} \frac{l}{2}. \quad (11)$$

$$\text{Maximum moment} = eP \sec \sqrt{\frac{P}{EI}} \frac{l}{2}. \quad (12)$$

$$\text{Maximum stress} = \frac{P}{A} + \frac{ePv}{I} \sec \sqrt{\frac{P}{EI}} \frac{l}{2}; \quad (13)$$

$$\begin{aligned} \text{Maximum stress} &= \frac{P}{A} \left(1 + \frac{ev}{r^2} \sec \sqrt{\frac{P}{EI}} \frac{l}{2} \right) \\ &= \frac{P}{A} \left(1 + \frac{ev}{r^2} \sec \sqrt{\frac{P}{AE}} \frac{l}{2r} \right), \end{aligned} \quad (14)$$

where A is the area of the section and r is the radius of gyration.

PROBLEMS.

1. A wooden bar 1 inch square and 5 feet long, as a column has the load 0.1 inch from the center of the section on a line through the center parallel to one side. If E is 1,500,000, what is the deflection at the middle of the length due to a load of 200 pounds?

$$\begin{aligned} \text{Ans. } \sqrt{\frac{P}{EI}} \frac{l}{2} &= 1.2 \text{ radian.} \\ y_{\max} &= 0.176 \text{ inch.} \end{aligned}$$

2. Find the maximum moment and fiber stress in Problem 1.

Ans. Maximum moment, 55.18 inch pounds;

Maximum compressive stress, 531 pounds per square inch.

3. Solve Problems 1 and 2 for a length of 75 inches.

Ans. $y_{\max} = 1.311$ inches; maximum compressive stress, 1894 pounds.

4. A 2-inch round steel rod 5 feet long is used as a column with ends free to turn. Find the deflection at the middle, and the maximum fiber stress on the concave side for a load of 10,000 pounds, if the eccentricity is 0.1 inch, and E is 30,000,000.

Ans. $y_{\max} = 0.0227$ inch; maximum stress, 4744 pounds per square inch.

5. Solve Problem 4 if the eccentricity is 0.01 inch; also for 0.5 inch.

6. Solve Problem 4 for loads of 20,000 pounds, 30,000 pounds, 50,000 pounds, 60,000 pounds, and 70,000 pounds for eccentricities of 0.01 inch and 0.1 inch.

<i>Ans.</i> Load:	20,000	30,000	50,000	60,000	70,000
Stress:	6,763	10,340	19,295	32,483	Infinite.
"	10,337	17,500	49,800	154,000	"

7. What load in Problem 6 will make $\sqrt{\frac{P}{EI}} \frac{l}{2} = 90$ degrees?

Ans. 64,570 pounds.

If we observe Problem 6, we find that a load of 50,000 pounds with an eccentricity of 0.1 inch produces a maximum stress of 49,800 pounds per square inch. If the ultimate strength of this steel in compression is 50,000 pounds per square inch, this is practically the ultimate load. On the other hand, a load of 60,000 pounds with an eccentricity of 0.01 inch produces a stress of 32,000 pounds, so that with the smaller eccentricity the load can go considerably above 60,000 pounds. A load of 64,570

pounds will cause failure with a column of these dimensions, no matter how small the eccentricity; for this load makes the angle $\sqrt{\frac{P}{EI}} \frac{l}{2}$ equal to $\frac{\pi}{2}$, an angle whose secant is infinity. A shorter column of the same dimensions will carry a greater load. A column 10 feet long and 2 inches in diameter will carry less than 16,200 pounds. A long column with the load exactly central, when the angle $\sqrt{\frac{P}{EI}} \frac{l}{2} = 90$ degrees, is in a condition of unstable equilibrium; the least vibration will start it to bend, and it will continue to bend without increase of load till it fails.

The formulas of this article are calculated on the assumption that E is constant. This is the case below the true elastic limit only. Beyond this limit the change in direction of the stress-strain diagram is practically the same as a reduction of the value of E . This reduction of E occurs in the outer fibers, which are subjected to the greatest stress, so that it causes some change in the location of the neutral axis and modifies the eccentricity. These formulas are, therefore, strictly correct only to the true elastic limit.

Within the true elastic limit these formulas are theoretically and experimentally correct. When the dimensions of the column are given and the eccentricity is known, equation (13) gives the unit stress. This equation may be used to determine whether a *given* column will carry a given load with safety.

108. Application of Column Formulas. — When it comes to computing the total load P which a given column will carry with a certain allowable unit stress, or to computing the size of column for a given load, these equations are not convenient, since neither of these quantities is expressed *explicitly*. Such problems may be solved by the method of trial. Choose some column and calculate the unit stress by equation (13) of Article 107; if it comes too high, choose a larger column until you get one for which the unit stress is equal to the allowable stress, or a little under this figure.

Where a number of such problems are to be solved, it is a great saving of time to represent equation (14) by means of a curve or table. To determine the relative values of $\frac{P}{A}$ and $\frac{l}{r}$ which make the unit stress equal to the ultimate strength of the

material for any assumed eccentricity of loading, we write the second form of equation (13):

$$\frac{ev}{r^2} \sec \sqrt{\frac{P}{AE}} \frac{l}{2r} = \frac{s_u}{\bar{P}} - 1,$$

where s_u is the ultimate strength of the material. It is difficult to solve for $\frac{P}{A}$ corresponding to a given value of $\frac{l}{r}$, but it is easy to solve for $\frac{l}{r}$ corresponding to a given $\frac{P}{A}$. The table below gives most of the work for steel, for which $E = 29,000,000$, $s_u = 48,000$, and the eccentricity is such that

$$\frac{ev}{r^2} = 0.2.$$

This table is computed by means of logarithms:

$$\text{Radians} = \text{degrees} \times \frac{\pi}{180};$$

$$\frac{l}{r} = 2 \times \text{radians} \times \sqrt{\frac{29,000,000}{\frac{P}{A}}};$$

$$\text{the log of } \frac{2\pi}{180} \sqrt{29,000} = 0.77411.$$

When $\frac{P}{A}$ is 8000, the angle is 87 degrees 42 minutes = 87.7 degrees;

Log 87.7	1.94300
	.77411
	2.71711
Log $\sqrt{8}$.45154
	2.26557

$$\frac{l}{r} = 184.3.$$

PROBLEM.

Calculate $\frac{l}{r}$ for $\frac{P}{A} = 9000, 11,000, 14,000$, and $18,000$ pounds per square inch.

TABLE VII.

ULTIMATE UNIT LOADS ON A COLUMN WITH ROUND ENDS.

Calculated from: ultimate strength, 48,000 pounds per square inch; E , 29,000,000; $\frac{e^2}{r^2}$ equals 0.2.

$\frac{P}{A}$ is ultimate unit load in pounds per square inch.

$\frac{l}{r}$ is the ratio of the length of the column to its radius of gyration.

$\frac{P}{A}$	$0.2 \sec \sqrt{\frac{P}{AE} \frac{l}{2r}}$	$\sec \sqrt{\frac{P}{AE} \frac{l}{2r}}$	$\sqrt{\frac{P}{AE} \frac{l}{2r}}$		$\frac{l}{r}$
			Degrees.	Radians.	
Pounds.					
1,000	47	235	89° 46'	1.566	533
2,000	23	115	89 30	1.562	376
3,000	15	75	89 14	1.557	306
4,000	11	55	88 58	1.552	264
5,000	8.6	43	88 40	1.547	236
6,000	7.0	35	88 22	1.542	214
8,000	5.0	25	87 42	1.531	184
10,000	3.8	19	86 59	1.518	164
12,000	3.0	15	86 11	1.504	148
16,000	2.0	10	84 17	1.471	125
20,000	1.4	7.0	81 47	1.427	108.8
24,000	1.0	5.0	78 41	1.373	94.4
26,000	.8462	4.231	76 20	1.332	88.8
28,000	.7143	3.571	73 44	1.387	82.8
30,000	.6000	3.000	70 32	1.231	76.6
32,000	.5000	2.500	66 25	1.159	69.8
34,000	.4119	2.059	60 57	1.064	62.2
36,000	.3333	1.667	53 07	.927	51.4
37,000	.2973	1.486	47 43	.833	46.6
38,000	.2632	1.316	40 32	.707	39.0
38,500	.2468	1.234	35 51	.626	34.4
39,000	.2308	1.154	29 55	.522	28.6
39,200	.2244	1.122	27 01	.471	25.6
39,400	.2182	1.091	23 36	.412	22.4
39,600	.2121	1.061	19 27	.339	18.4
39,700	.2090	1.045	16 57	.296	16.0
39,800	.2060	1.030	13 53	.242	13.0
39,900	.2030	1.015	9 52	.172	9.2
40,000	.2000	1.000	0	.0	0

Fig. 145 shows the values of the unit load, $\frac{P}{A}$, which make the unit stress in the outer fibers on the concave side of a steel column 48,000 pounds per square inch (provided the elastic limit is 48,000 pounds, as in the case of cold-rolled steel, for instance). The curves are calculated for a modulus of 29,000,000. Curve I is plotted from Table VII where $e = \frac{0.2 r^2}{v}$. Curve II is plotted for an eccentricity one-half as great, $\frac{ev}{r^2} = 0.1$, column III of Table VIII. Curve III is plotted from zero eccentricity, the second column of Table VIII.

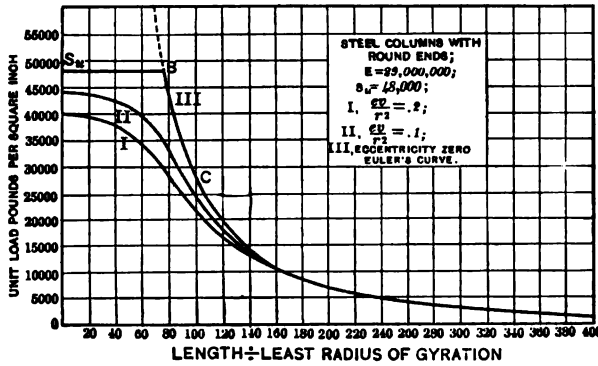

Fig. 145. — Column Curves.

We notice that the eccentricity makes a large difference for values of $\frac{l}{r}$ less than 100. For values greater than 160 the eccentricity makes little difference.

We will now apply one of these curves to the solution of a problem. Suppose we want a solid circular column 80 inches long with round ends to carry a load of 40,000 pounds with a factor of safety of 4; and suppose that we are sure that the eccentricity of the load is not greater than one-twentieth of the radius.

If a is the radius,

$$v = a; r = \frac{a}{2}; e = \frac{a}{20}; \frac{ev}{r^2} = 0.2.$$

Curve I may be used. We will find the column for which the ultimate load is 160,000 pounds.

A short block with this eccentricity will require an area of 4 square inches. The diameter must be at least 2.2 inches (use table in Cambria to find diameters from areas); $\frac{l}{r}$ is less than 150 [80 ÷ 0.55 = 145]. If we look on curve I, we find the corresponding value of $\frac{P}{A}$ is about 12,000 pounds per square inch, requiring a section of about 13 square inches. The area required is between 4 square inches and 13 square inches. As the next step in this trial method, take an area which is about midway between 4 and 13. This mean area has a diameter of about 3.2 inches, which we will take because it gives $\frac{l}{r}$ equal to 100. The work may be arranged as shown below.

Diameter in inches.	Radius of gyration.	$\frac{l}{r}$.	$\frac{P}{A}$ from curve.	Area.	Total load.
3.2	.80	100	22,000	8.04	176,900
3.0	.75	107	20,500	7.07	145,000
(Interpolate for the diameter which gives 160,000. Result, 3.09.)					
3.09	.772	104	21,000	7.50	157,500
3.10	.775	103	21,200	7.55	160,060

Note that this calculation gives the column in which the total load is one-fourth the ultimate load. If we take a column 3.1 inches in diameter and compute the maximum stress when the total load is 40,000 pounds, we find it to be about one-seventh of 48,000 pounds per square inch. The difference is due to the fact that the secant is not proportional to the angle.

PROBLEMS.

8. Using curve I, find the diameter of a steel column 50 inches long to carry a load of 10,000 pounds with a factor of safety of 3.

9. Using curve I, find the Z-bar column 15 feet long to carry a load of 150,000 pounds with a safety factor of 4.

Ans. A column made of four 5-inch by $\frac{5}{16}$ -inch Z-bars with one 7-inch by $\frac{5}{16}$ -inch plate.

109. Euler's Formula. — As any column will fail when $\sqrt{\frac{P}{EI}} \frac{l}{2}$ becomes 90 degrees, we have, as the upper limit of possible loading, the condition:

$$\sqrt{\frac{P}{EI}} \frac{l}{2} = \frac{\pi}{2};$$

from which

$$P = \frac{\pi^2 EI}{l^2}$$

$$\frac{P}{A} = \pi^2 E \left(\frac{r}{l}\right)^2.$$

Formula XXIII

Formula XXIII is Euler's formula. It may be derived directly from equation (1) of Article 107 for the case where the eccentricity is 0.

$$EI \frac{d^2y}{dx^2} = -Py. \quad (1)$$

Multiply by dy ,

$$EI \frac{d^2y}{dx^2} dy = -Py dy. \quad (2)$$

$$\frac{d^2y}{dx^2} dy = \frac{dy}{dx} \frac{d^2y}{dx} = z dz \text{ where } z = \frac{dy}{dx}.$$

$$\frac{EI}{P} z dz = -y dy. \quad (3)$$

$$\frac{EIz^2}{P} = -y^2 + C_1^2. \quad (4)$$

$$\sqrt{\frac{EI}{P}} \frac{dy}{dx} = \sqrt{C_1^2 - y^2}. \quad (5)$$

$$\sqrt{\frac{P}{EI}} dx = \frac{dy}{\sqrt{C_1^2 - y^2}}. \quad (6)$$

$$\sqrt{\frac{P}{EI}} x = \sin^{-1} \frac{y}{C_1} + C_2. \quad (7)$$

$y = 0$ when $x = 0$, hence $C_2 = 0$ (or $n\pi$).

Using

$$C_2 = 0, \\ \sin \sqrt{\frac{P}{EI}} x = \frac{y}{C_1}. \quad (8)$$

When $x = l$, $y = 0$,

$$\sin \sqrt{\frac{P}{EI}} l = 0; \\ \sqrt{\frac{P}{EI}} l = \pi \text{ (or } n\pi);$$

$$P = \frac{\pi^2 EI}{l^2}. \quad \text{Formula XXIII.}$$

From equation (8) we see that the curve of the column is a sine curve. Formula XXIII contains I but does not include the distance to the outer fiber. From this we conclude that when

the eccentricity is indefinitely small, and the length compared with the radius of gyration is sufficiently great for the column to fail by bending, the value of the ultimate load does not depend upon the form of the column except in so far as the form changes the value of I .

Curve III of Fig. 145 is Euler's curve for a modulus of elasticity of 29,000,000. As a mathematical curve it is of infinite length. As an engineering curve it *must not be used* above the point B , where the unit load is the ultimate compressive strength of the material.

Since Euler's curve is derived on the assumption of a constant modulus of elasticity, it is really good *to the true elastic limit only*. For ordinary structural steel, the true elastic limit is about 30,000 pounds per square inch. Curve III of Fig. 145 is correct below the point C for values of $\frac{l}{r}$ greater than 98. From C to B it gives too great values for the unit load. Above B , if 48,000 is the ultimate compressive strength, it is a mathematical fiction, "out of bounds."

We will see later that it is better to use Euler's curve only for values of $\frac{l}{r}$ which make the ultimate load *one-third* of the *ultimate* strength.

PROBLEMS.

1. A yard stick, with the ends slightly rounded, was placed vertical with the lower end on a platform scale and a load was applied to the upper end (Fig. 143). The load and deflection were measured.

Load in pounds.	Deflection at the middle, in inches.
5.00.....	0.03
6.00.....	0.20
6.40.....	0.25
6.48.....	1.00 (Load dropped to 6.28.)
6.28.....	2.50

Calculate EI from the last two readings by Euler's formula. *Ans.* 851, 825.

2. The yard stick of Problem 1, supported as a beam at points 34 inches apart, was deflected $\frac{1}{4}$ inch at the middle by a load of 1 pound at the middle. Find EI and compare the result with Problem 1.

3. The yard stick above mentioned was 1.06 inch wide and 0.18 inch thick.

Find E and $\frac{l}{r}$.

4. Find the total load with a factor of safety of 4 on a round steel rod 2 inches in diameter for lengths of 20, 40, 60, 80, and 100 inches, if the ultimate

compressive strength of the steel is 50,000 pounds per square inch and E is 30,000,000.

	Length.	Ultimate unit load.	Total safe load.
Ans.	20 inches.....	185,060.....
	40 ".....	46,260.....
	60 ".....	20,560.....	16,148
	80 ".....	11,565.....	9,090
	100 ".....	7,400.....	5,813

Why not use the results for the first two lengths?

5. Find the total safe load, with a factor of safety of 4, on a 4-inch by 4-inch wooden post, 12 feet long, if E is 1,500,000, and the ultimate strength is 5000 pounds per square inch. Ans. 3808 pounds.

6. Should Euler's formula be applied to the post of Problem 5 if the length is 6 feet? 4 feet? Why?

TABLE VIII.

ULTIMATE UNIT LOADS ON A COLUMN WITH ROUND ENDS.

Calculated by Euler's formula and by equation (14) of Article 107 for three values of s_u , with $\frac{e}{r^2} = 0.1$, and $E = 29,000,000$.

Unit load, $\frac{P}{A}$	$\frac{l}{r}$, Length divided by least radius of gyration.			
	Euler's.	$s_u = 48,000$.	$s_u = 40,000$.	$s_u = 32,000$.
Pounds.				
1,000	535	534	534	534
2,000	378	377	377	377
3,000	309	307	307	307
4,000	268	266	266	266
5,000	239	237	237	237
6,000	218	216	216	216
8,000	189	186	186	186
10,000	169	166	166	166
12,000	154	151	150	150
14,000	143	139	138	138
16,000	134	129	128	128
18,000	126	121	120	116
20,000	120	114	112	107
22,000	114	108	105	98
24,000	109	102	99	88
26,000	105	97	92	77
28,000	101	92	86	51
29,000	16
30,000	98	87	79	
32,000	95	82	70	
34,000	92	77	57	
36,000	89	72	26	
38,000	87	65		
40,000	85	56		
42,000	82	42		

110. **Effect of Ultimate Strength of Material on Strength of Columns.** — We notice from Euler's formula that the ultimate load on a long column depends upon the modulus of elasticity and the moment of inertia of the cross section and is independent of the ultimate strength of the material. The ultimate strength of the material, however, determines the lower limit of $\frac{l}{r}$, for which Euler's formula may be used.

Euler's formula assumes zero eccentricity. From the curves of Fig. 145 we see that the eccentricity makes little difference if $\frac{l}{r}$ is greater than 160. The effect of the ultimate strength and small eccentricity together is shown in Table VIII. This table, calculated like Table VII, gives the values of the unit load for the eccentricity $e = \frac{0.1 r^2}{v}$ for three values of the ultimate strength. The table also gives the results of Euler's formula. We notice that there is little difference when $\frac{l}{r}$ is 140. When $\frac{l}{r}$ becomes less than 100 the difference is great.

111. **Classification of Columns.** — Columns may be divided, according to the nature of the ends, into the following classes:

I. Both ends free to turn about horizontal axes but not free to move laterally, Figs. 144 and 146, I.

II. One end fixed and the other end free to turn and free to move laterally, Fig. 146, II.

III. Both ends fixed so that the tangents at the ends do not change, Fig. 146, III.

IV. One end fixed and the other end free to turn about one or more horizontal axes, but not free to move laterally, Fig. 146, IV.

Case I is the only one so far considered. If L is the total length of the column, and l is the length of the sine curve ABC as used in the theory of Articles 107 and 109, $l = L$ for case I.

In case II, the entire column of length L corresponds to the upper half AB of the sine curve. Hence for case II we use $2L$ for l in Formulas XXII and XXIII.

In case III, $\frac{dy}{dx}$ is zero at each end and at the middle. The middle half ABC corresponds to the sine curve of case I. This

portion of the sine curve is represented by l in the formulas.

If L is the entire length DF , then $l = \frac{L}{2}$. A column with both ends rigidly fixed will carry as great a load as a column of half its length with ends free to turn.

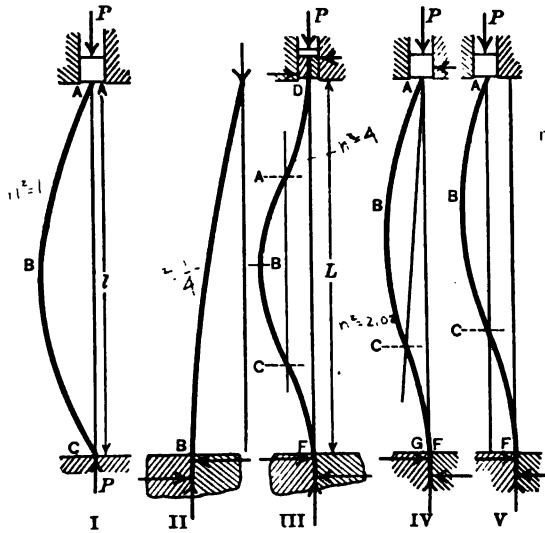

Fig. 146. — Types of Ideal Columns.

The points A and C , at one-fourth the length from the ends, are points of counterflexure. The portion AD is one-half of a sine curve. If revolved 180 degrees in the plane of the paper about the point A , the curve AD will coincide with AB . The moment is zero at A and C . Case IV is fixed at one end and free to turn at the other, but not free to move laterally. The point of counterflexure is at C . As there is no moment at C , the resultant force at A must be in the direction AC . The portion ABC forms a sine curve similar to the preceding cases with the line AC corresponding to the X axis in Fig. 144. The lower portion CF forms a part of a sine curve as far as the plane of the body which holds it. Below that plane it is straight. The portion CG is less than one-half of AC . It is evident, therefore, that AC is more than two-thirds of L . The solution of the differential equation shows that AC is nearly $0.7 L$.

$$l = 0.7 L \quad l^2 = 0.5 L^2 \text{ nearly.}$$

In Fig. 146, V, the top of the column has been displaced laterally. If this displacement is such that the point B is as far from the line AC as the top A is displaced from the vertical line through F , then the line AC from the end to the point of counterflexure becomes vertical. In this position AC is two-thirds of L , there is no horizontal force at the top, and the vertical force P is greater than in Fig. 146, IV. The position is unstable and easily changes to the one in which the curves are reversed, with C and B deflected to the right of the vertical line through F , in which position the load P , which produces a large deflection, is less than in case IV.

The ratio of $\frac{1}{r}$ is called the slenderness ratio.

PROBLEMS.

1. A yard stick, with ends rounded, was deflected a large amount by a load of 6.1 pounds at the end, as in case I. Find EI by Euler's formula.

2. The same yard stick was clamped 4 inches from one end and the load was applied as in Fig. 146, IV. It was found that a load of 15.42 pounds produced a deflection of over 1.5 inches. Find EI by Euler's formula.

3. The load in Problem 2 was displaced 1 inch south of the vertical line through the bottom. The vertical component of this load was 17.12 pounds with a deflection of 2 inches south. The horizontal component was found to be zero. Find EI , using two-thirds of 32 inches as l .

4. A solid circular steel rod stands in a vertical position with the lower end fixed. A load of 100,000 pounds is applied at the free upper end at a distance of 1 inch from the center. The diameter of the rod is 6 inches, and its length from the fixed point is 15 feet. If E is 30,000,000, find the deflection at the end and the maximum fiber stress by the formulas of Article 107.
Ans. Maximum stress, 21,320 pounds per square inch.

112. **End Conditions in Actual Columns.** — The classification of Article 111 represents *ideal* conditions, which are only approximated in practice. The columns in actual use are:

Round-end columns, which end with spherical or cylindrical surfaces. They sometimes end with knife-edges, which may be regarded as cylinders of small radius. The *round* surfaces roll on *plane* surfaces with practically no friction. Round-end columns are not used in structures and are rarely used in machines. They are used in tests to check the accuracy of theory, as they fulfill very closely the conditions of case I of ends free to turn.

A *pin-end* or *hinged-end column* ends with cylindrical surfaces which turn in *cylindrical bearings* (Fig. 147). Fig. 148 shows one end of a pin-connected column made of two channels latticed together. This form of connection is commonly used in bridges.

A column which ends with a ball and socket is practically the same as a hinged-end column, except that it is free to turn in any plane instead of in the single plane normal to the axis of the hinge.

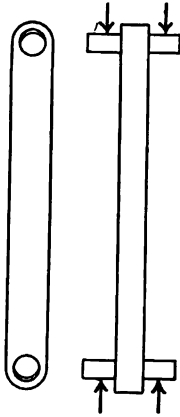

Fig. 147. — A Pin-end Column.

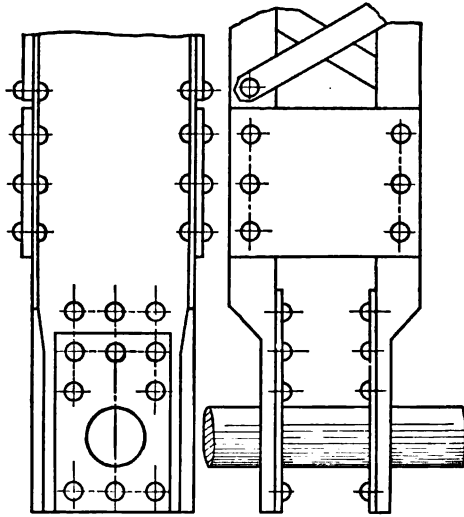

Fig. 148. — End of Pin-connected Bridge Post.

If the pin of a hinged-end column rolled on a plane surface, there would be little friction, and the case would be the same as that of the round-end columns. Usually the pin turns in a close-fitting bearing, so that the friction is considerable. A hinged-end column may be anywhere between case I, with the ends free to turn, and case III, with the ends fixed. If the pin is small, the moment arm of the friction is small, and a slight eccentricity will cause it to turn. If the pin is large, the opposite is true. In the moving parts of machinery, the pin connections are lubricated so that they turn easily. The connecting rod of an engine is an example.

Fig. 149 shows, diagrammatically, the behavior of a pin-end column. At first it acts as a column with fixed ends (Fig. 149, I). When the moment at the end becomes greater than the product of the starting friction at the surface of the pin multiplied by its radius, the column turns at the end to some position similar to Fig. 149, II. In this position, the points of counterflexure *A*

and C are nearer the ends, and the moment on the pins is less. The column may finally change to the position of Fig. 149, III, which is that of case I. In this last position, it will support a load much smaller than in the first position. If the ratio of the length to least radius of gyration is 200 or more, so that Euler's formula applies to both the whole and the half length, the column in the last position will carry a load only one-fourth as great as in the first one.

Some interesting tests of columns were made at the Pencoyd Iron Works in 1883 by James Christie.* In these tests, some of the so-called *hinged-end* columns were fitted with hemispherical balls turning in sockets. The balls were located as nearly as possible in the line of the axis of the column by careful measurements. Owing to the fact that no column is absolutely straight and perfectly uniform in section and homogeneous in structure throughout its entire length, this method did not always put the centers of the hemispheres exactly

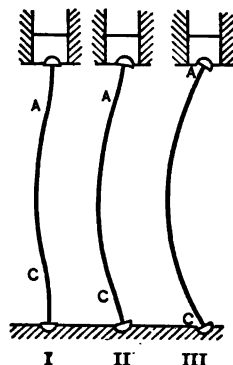

Fig. 149.—Deflection of Hinged-end Column.

on the axis of the column. The final adjustment was determined by trial in the testing machine; a small load was applied and the deflection measured. The hemispheres were then moved a little and the test repeated, until a position was found where a considerable load caused no appreciable deflection. The column was then loaded to failure.

† “When the point of greatest strength was reached, the behavior of the specimen was peculiar. Under ordinary circumstances the bar, while bending under strain, rotated from the start on its hinged ends. When correctly centered, no such rotation occurred at the beginning of the deflection, but the bar bent like a flat-ended strut, till the point of failure was reached, when it rotated on its ends suddenly, as sometimes to spring from the machine.” These results could not be secured when the balls or pins rolled on plane surfaces, and were difficult to get when the pins were small.

The effect of the size of the pin was shown in these experi-

* Transactions of the American Society of Civil Engineers, 1883, pages 85-122.

† Ibid., page 87.

ments. Two angles of the same length were cut from the same bar. One of these tested with a 2-inch ball and socket failed at 36,500 pounds per square inch; the other tested with a 1-inch ball and socket failed at 24,010 pounds. Similar results were obtained in other experiments.

These tests and many others show that the friction at the ends of a hinged-end column partially fixes the ends and increases the ultimate strength. It must be remembered, however, that in the testing machine the loads are applied with little vibration. In structures such as railway bridges, where there is large vibration, it is probable that the friction of the pins gives little help, and it is safest to regard hinged-end columns as equivalent to round-end columns.

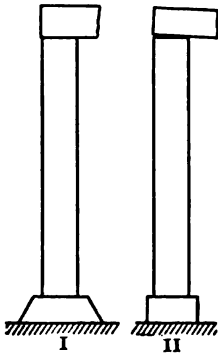

Fig. 150. — Square-end Columns.

Square-end or *flat-end* columns end with plane surfaces in contact with plane surfaces. They must be accurately fitted if eccentric loading is to be avoided. If a beam resting on a square-end column bends under its load (Fig. 150, II), the load on the column becomes eccentric. Footings which support columns often settle unevenly and cause large eccentricity.

Pin-end columns are practically square-end with respect to the axis of the pin.

A column with a pin connection at one end and a square connection at the other is called a *pin-and-square* column. This term includes columns with one end *fixed* and the other hinged. This column approximates the conditions of case IV.

Fixed-end columns are riveted to the remainder of the structure in buildings and bridges. In machines they are fastened in various ways. The connection can never be absolutely rigid, and the member to which the column is fixed must suffer some deflection, so that there is always some change in the slope of the tangent at the "fixed" points. When the column is very flexible compared with the body to which it is fixed, it may then be regarded as an example of the ideal case and l may be taken as equal to half the length L . In the case of the yard stick described in Problem 2 of Article 111, the column was firmly clamped to the 2-inch by 4-inch post and the value of $\frac{L}{r}$ was

over 800, making it relatively very flexible, so that this gave consistent results when treated as an example of a column fixed at one end. In machines this condition is sometimes met, but it never occurs in structures.

113. **Some Experiments Showing Effect of End Conditions.** —

It is evident that the value of l to be used with "square-" and "fixed-" end columns in calculating the unit load is greater than $\frac{L}{2}$ and less than L . In the case of the "pin-and-square" column,

it is less than L and (if the friction of the pin is small) greater than $0.7L$. The best values to be used should be determined from tests of full-size columns under a wide range of conditions.

The experiments of Christie, previously mentioned, are instructive in this regard. In Table IX are the results of these experiments for angle and tee sections.*

In this table L is the total length of the column as in Fig. 146, and r is the least radius of gyration. It was found that the columns failed in the direction for which radius of gyration was the minimum.

The figures in this table give us some idea of the relative value of hinged, flat, and fixed ends, as compared with round ends. In the case of the hinged ends, owing to the lack of vibration, the load was probably greater than would be found under the conditions of railway bridges subjected to the jar of fast trains. The fixed ends were clamped to the testing machine, which was relatively rigid. Notice that with the short lengths, where the columns were relatively stiff, the fixed-end columns were inferior to the flat ends and only a little better than the hinged ends.

With $\frac{L}{r}$ greater than 100 the superiority of the fixed ends becomes marked.

If we consider the table, we find that with $\frac{P}{A}$ equal to 25,000 pounds per square inch, $\frac{L}{r}$ is 80 for round ends. For flat ends this value of $\frac{P}{A}$ lies between the values 120 and 140 for $\frac{L}{r}$. If

* These figures are averages of the results for angles and tees from the table on page 116 of the Transactions of the American Society of Civil Engineers for 1883. The results for channels and I-beams are not included in these averages, as these were used with the flat-end condition only.

we interpolate between 26,500 and 23,250 we get $\frac{L}{r} = 129$ for $\frac{P}{A} = 25,000$. As far as this experiment goes, it indicates that in calculating a flat-end column the value of l in the formulas should be taken as $\frac{80L}{129} = 0.62L$. In the same way for fixed ends we find that $\frac{L}{r} = 144$ gives $\frac{P}{A}$ equal to 25,000. This makes $l = 0.56L$ for this particular case.

TABLE IX.
PENCOYD TESTS OF WROUGHT-IRON STRUTS.
Average Results for Angles and Tees.

$\frac{L}{r}$	$\frac{P}{A}$, Ultimate unit load in pounds per square inch.			
	Round ends.	Hinged ends.	Flat ends.	Fixed ends.
20	44,000	46,000	49,000	45,000
40	36,500	40,500	41,000	38,000
60	30,500	36,000	36,500	34,000
80	25,000	31,500	33,500	32,000
100	20,500	28,000	30,250	30,000
120	16,500	24,250	26,500	28,000
140	12,800	20,250	23,250	25,500
160	9,500	16,350	20,500	23,000
180	7,500	12,750	18,000	20,000
200	6,000	10,750	15,250	17,500
220	5,000	8,750	13,000	15,000
240	4,300	7,500	11,500	13,000
260	3,800	6,500	10,250	11,000
280	3,200	5,750	8,750	10,000
300	2,800	5,000	7,350	9,000
320	2,500	4,500	5,750	8,000
340	2,100	4,000	4,650	7,000
360	1,900	3,500	3,900	6,500
380	1,700	3,000	3,350	5,800
400	1,500	2,500	2,950	5,200
420	1,300	2,250	2,500	4,800
440	2,100	2,200	4,300
460	1,900	2,000	3,800
480	1,700	1,900

PROBLEMS.

1. Using $\frac{L}{r}$ equals 60 for round ends, find the equivalent lengths of hinged, flat, and fixed ends, and the corresponding values of l in terms of the entire length L .
Ans. $l = 0.70 L, l = 0.61 L, l = 0.63 L$.

2. Using $\frac{L}{r}$ equals 100 for round-end columns, find the corresponding values for hinged, flat, and fixed ends, and values of l in terms of L .

Ans. $\frac{L}{r} = 138, 160, 177$.

If we take all the values for round ends from 40 to 200 inclusive and determine the values of $\frac{L}{r}$ which give the same unit load for the other end conditions, we get the following ratios:

	Hinged.	Flat.	Fixed.
Minimum.....	1.29	1.50	1.25
Maximum.....	1.45	1.69	1.87
Mean of all.....	1.37	1.60	1.72

In the case of the fixed ends, only one value was below 1.50.

As far as these figures go, they indicate that a flat-end column 16 feet long, a fixed-end column 17.2 feet long, or a hinged-end column 13.7 feet long, will carry the same total load as a round-end column 10 feet long of the same cross section.

Lewis P. McGilvary
 Elect. Eng. 1916

CHAPTER XIII.

COLUMN FORMULAS USED BY ENGINEERS.

114. **Straight-line Formulas.**— We have found that for large values of $\frac{l}{r}$, Euler's formula may be used, and a considerable eccentricity makes little difference. For smaller values of $\frac{l}{r}$, Euler's formula must not be used, and a small eccentricity makes a large difference with the results of the secant formula of Article 107. In structures there is generally considerable uncertainty in regard to the amount of eccentricity. This is especially true for flat- or fixed-end columns. It is, therefore, not worth while to go through the labor of calculating with these formulas (except in the case of a column with a relatively large known eccentricity). Engineers make use of simpler working formulas. Of these, Rankine's formula was formerly most used. At present, the *straight-line formulas* are preferred.

A straight-line column formula for the ultimate unit load has the form:

$$\frac{P}{A} = s_u - k \frac{l}{r}. \quad \text{Formula XXIV.}$$

The student will recognize this as the equation of a straight line through the point $(0, s_u)$ and sloping downwards. If we draw a straight line through the point $(0, s_u)$ of Fig. 145, and tangent to Euler's curve III, we find that this straight line does not deviate far from curves I and II. Except for small values of $\frac{l}{r}$, a small change in the eccentricity will cause the curve to change from one side of this straight line to the other. Such a straight line, then, will give a fair value of the unit load for the *uncertain* eccentricities which occur in practice, for all values of $\frac{l}{r}$ to the left of the point of tangency except extremely small ones.

Fig. 151 shows the method of obtaining the constant of a straight-line formula graphically. Curve I is Euler's curve for steel with E equal to 30,000,000, and s_u , 50,000. The straight line

II is drawn from the point s_u , whose coördinates are (0, 50,000), tangent to curve I. The coördinates of the point of tangency, D , are 133 and 16,700. To get the equation of the straight line,

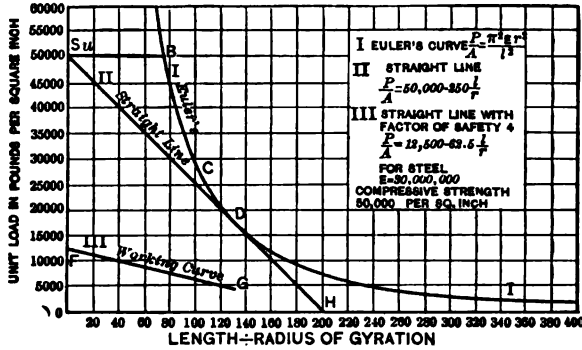

Fig. 151. — Straight Line and Euler's Curves.

we notice that its ordinate is 25,000 when its abscissa is 100; that is, it drops 25,000 in 100. The equation is then

$$\frac{P}{A} = 50,000 - 250 \frac{l}{r} \tag{2}$$

Beyond D the straight line falls below Euler's curve. It should not be used for values of $\frac{l}{r}$ greater than 140, as the results beyond this limit are unnecessarily small.

The straight line should be used to the point of tangency (or a little farther) and Euler's equation beyond that point.

Curve III is the straight line for allowable values of $\frac{P}{A}$ for a factor of safety of 4. It stops at G where $\frac{l}{r}$ is 133. Beyond that point use Euler's and divide the result by 4.

PROBLEMS.

1. Using equation (2), solve Problem 4 of Article 109 for the lengths of 20 inches, 40 inches, and 60 inches with a safety factor of 4.

Ans. Total safe loads, 31,400, 23,560, and 15,700 pounds.

2. Find the total load with a factor of safety of 4 on a 4-inch by 4-inch by $\frac{1}{4}$ -inch angle with ends free to turn, for lengths of 5 feet, 10 feet, and 15 feet.

Ans. 28,850, 11,730, and 5210 pounds.

3. Plot Euler's curve for timber for $E = 1,500,000$. Draw straight line if ultimate strength is 5000 pounds per square inch. Derive a working straight-line equation with a factor of safety of 5.

115. **Algebraic Derivation of the Straight-line Formulas.**— While a straight-line formula may always be derived graphically by plotting Euler's curve and drawing the tangent, it may also be derived by the methods of the Calculus, being the problem of drawing a straight line through a given point tangent to a given curve. We may write Euler's formula:

$$y = \frac{a}{x^2}, \quad (1)$$

where $y = \frac{P}{A}$, $x = \frac{l}{r}$, and $a = \pi^2 E$.

Our problem is to draw a tangent to the curve (1) which shall pass through the point $(0, s_u)$. The equation of this tangent line is:

$$y = -\frac{2a}{x_1^3}x + s_u, \quad (2)$$

where x_1 is the abscissa of the point of tangency.

Since the straight line (2) passes through the point of tangency whose coordinates are (x_1, y_1) , these coordinates satisfy the equation of the line; hence

$$y_1 = -\frac{2a}{x_1^3}x_1 + s_u. \quad (3)$$

Also, since the point of tangency is on the curve, these coordinates satisfy equation (1); and

$$y_1 = \frac{a}{x_1^2}. \quad (4)$$

Combining (3) and (4) for the coordinates of this point of contact:

$$y_1 = \frac{s_u}{3}, \quad \text{Formula XXV.} \quad (5)$$

$$x_1^2 = \frac{3a}{s_u}. \quad (6)$$

We may substitute the value of x_1 in equation (2) and get the desired straight-line equation. It is better simply to use the easily remembered fact that the ordinate of the point of tangency to Euler's curve is one-third of the Y intercept of the straight line (Formula XXV). Substitute this value in Euler's equation and get the abscissa of the point of tangency. This gives the coordinates of two points on the straight line from which to write its equation.

The abscissa of the point of contact is the lower limit of $\frac{l}{r}$ for Euler's formula. It is also the upper limit for the straight-line formula, although, if it is exceeded by a small amount, the error is small and on the safe side.

Referring to Fig. 151, Euler's curve might be used, if there is no eccentricity, up to the point *C*, the true elastic limit; but with the uncertain eccentricity which occurs in practice it is best to use it only to *D*. When you solve by Euler's formula for the ultimate unit load and get a result greater than one-third the ultimate strength of the material, discard your work and solve by a straight-line formula (or by Rankine's formula). If the value of $\frac{P}{A}$ by Euler's formula comes out less than one-third of s_u , it may be used when divided by suitable factor of safety.

PROBLEMS.

1. Find a straight-line equation with a factor of safety of 5 for long-leaf yellow pine for which the ultimate compressive strength is 5000 pounds per square inch and E is 1,500,000.

When $\frac{P}{A}$ is $\frac{5000}{3}$, $\frac{l}{r}$ in Euler's formula is $30 \pi = 94.2$.

The slope of the line is 3333 divided by 94.2 = 35.4.

For the ultimate load:

$$\frac{P}{A} = 5000 - 35.4 \frac{l}{r}.$$

With a factor of safety of 5:

$$\frac{P}{A} = 1000 - 7 \frac{l}{r}.$$

2. With the data of Problem 1, find the total safe load, with a factor of safety of 5, on a 6-inch by 6-inch long-leaf yellow-pine post for lengths of 10 feet, 15 feet, and 20 feet. *Ans.* 18,500, 9870, and 5550 pounds.

3. Using timber having an ultimate strength of 5000 pounds per square inch and a modulus of elasticity of 1,200,000, derive a working straight-line formula with a factor of safety of 4.

Ans. $\frac{P}{A} = 1250 - 10 \frac{l}{r}$, for values of $\frac{l}{r}$ up to 85.

4. Derive a straight-line formula for cast iron for which E is 15,000,000 and the ultimate compressive strength is 50,000, with a factor of safety of 5.

Ans. $\frac{P}{A} = 10,000 - 70 \frac{l}{r}$, for values of $\frac{l}{r}$ up to 95.

5. Calculate the total safe load on a hollow cast-iron column 8 inches diameter and 1 inch thick for lengths of 10 feet and 15 feet.

Ans. 146,000, 109,100 pounds.

6. Using $E = 29,000,000$ and $s_u = 45,000$, find the straight-line formula with a safety factor of 3 for structural steel columns with round ends.

Ans. $\frac{P}{A} = 15,000 - 72 \frac{l}{r}$, up to about 140.

116. **The Ultimate Strength.** — The straight-line formulas depend upon s_u , the ultimate compressive strength of the material in a short block. In the Pencoyd tests of Table IX, this figure seems to be about 49,000 pounds per square inch for wrought iron. This is considerably above the yield point of the iron used.

These tests were made slowly, so that there was ample time for the raising of the elastic limit, which occurs when wrought iron and soft steel are loaded beyond the yield point. Also the columns used in these tests were each made of a single piece, so that there was not that opportunity for local failure which exists in columns built up of several pieces riveted together.

For built-up columns, the ultimate strength is the yield point of the material.

Fig. 152 shows one of a set of wrought-iron columns tested at Watertown Arsenal in 1884 ("Tests of Metals," 1884, page 17). The column was tested with 3.5-inch pins. The length center to center of pins was 20 feet, and the deformation was measured in a gauged length of 200 inches. The average cross section of channels and plates was determined from the weight and specific gravity. The cross sections were:

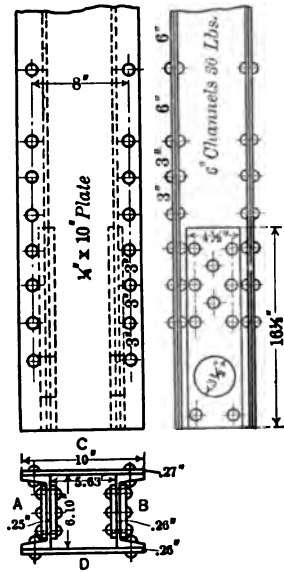

Fig. 152.— Column Tested at Watertown Arsenal.

	Square inches.
Channel A.....	3.00
Channel B.....	3.05
Plate C.....	2.66
Plate D.....	2.60
	11.31

The initial load was 5000 pounds. The set was determined by returning to the initial load after each 50,000 pounds increment. The deflection at the middle was measured perpendicular and parallel to the pins. Some of the readings are given in Table X.

TABLE X.
TEST OF WROUGHT-IRON PLATE AND CHANNEL COLUMN AT
WATERTOWN ARSENAL.

Total load.	Compression in gauged length of 200 inches.	Deflection at the middle.	
		Perpendicular to pins.	Parallel to pins.
Pounds.	Inch.	Inch.	Inch.
5,000	.0	.0	.0
30,000	.0169	.0	.0
50,000	.0293	.01	.01
5,000	.0	.0	.0
80,000	.0482	.01	.01
100,000	.0610	.02	.01
5,000	.0	.0	.0
130,000	.0804	.03	.02
150,000	.0931	.03	.02
5,000	.0010	.0	.01
180,000	.1118	.04	.03
200,000	.1247	.04	.03
5,000	.0016	.0	.02
230,000	.1444	.06	.03
250,000	.1580	.07	.03
5,000	.0041	.0	.03
260,000	.1651	.09	.03
270,000	.1725	.10	.03
280,000	.1797	.12	.03
290,000	.1870	.13	.03
300,000	.1954	.17	.03
5,000	.0110	.03	.03
310,000	(Micrometer removed)	.20	.03
320,00027	.03
325,00032	.03
330,00045	.03
330,10048	.03

Failed by deflection perpendicular to the plane of the pins; with plate C on the convex side.

"After reaching the maximum load, the deflection increased slowly till it reached 0.75 inch, the load at the time being 320,000 pounds. From this point the rate of deflection accelerated till it reached 1.80 inches under 310,000 pounds load, when sudden springing occurred, increasing the deflection to 3.35 inches, while the pressure fell to 155,000 pounds.

"Released to the initial load, the deflection was 2.08 inches.

"A sharp bend was found 20 inches from the middle of the post; the plate on the concave side buckled between the riveting. Pinholes elongated 0.01 inch."

In this test the maximum load was nearly 29,200 pounds per square inch. The unit stress on the concave side was this figure plus the stress due to bending. We get the maximum bending moment by multiplying the load by the deflection 0.48 inch. The moment of inertia of the section with respect to an axis parallel to the pins is about 86. This gives a bending stress of 6100 pounds, making the total compressive stress at the beginning of failure 35,300 pounds per square inch.

It is probable that at the beginning of failure the column was in condition I of Fig. 149, the friction causing it to act as if the ends were fixed. In this case the moment arm is only half the deflection at the middle and the actual maximum stress is only 32,000 pounds per square inch.

Other columns of the same set gave similar results. Other sets of tests, notably those of Buchanan* for the Pennsylvania Railroad, agree in indicating that the value of s_u should not exceed 35,000 for wrought iron and 40,000 for structural steel.

PROBLEMS.

1. Using $E = 27,500,000$ and $s_u = 35,000$, derive a straight-line formula for the ultimate load on wrought-iron columns, also a working formula with a factor of safety of 2.5.

$$\text{Ans. } \begin{cases} \frac{P}{A} = 35,000 - 153 \frac{l}{r}; \text{ point of tangency at } 152.5; \\ \frac{P}{A} = 14,000 - 61 \frac{l}{r}. \end{cases}$$

2. Using $E = 29,000,000$ and $s_u = 40,000$ for structural steel, derive a working straight-line formula with a factor of safety of 2.5.

$$\text{Ans. } \frac{P}{A} = 16,000 - 73 \frac{l}{r} \text{ to about } 150.$$

The American Railway Engineering and Maintenance of Way Association has adopted for structural steel

$$\frac{P}{A} = 16,000 - 70 \frac{l}{r}, \quad \text{Formula XXVI.}$$

with a maximum of 14,000.

This formula, which we will call the American railway formula, is practically the same as the results of Problem 2.

Fig. 153 shows the reason for having a maximum value and not carrying the straight line entirely back to the Y axis. In this figure, curve I gives the ultimate values of $\frac{P}{A}$ which make

* *Engineering News*, Dec. 26, 1907.

the unit stress 40,000 pounds per square inch calculated in the same way as the curves of Fig. 149 for $\frac{eV}{r^2} = 0.1$ (column IV of Table VIII). This curve is nearly horizontal at first, with a maximum value of 36,360 pounds per square inch. Curve II is the American railway formula multiplied by 2.5, which makes

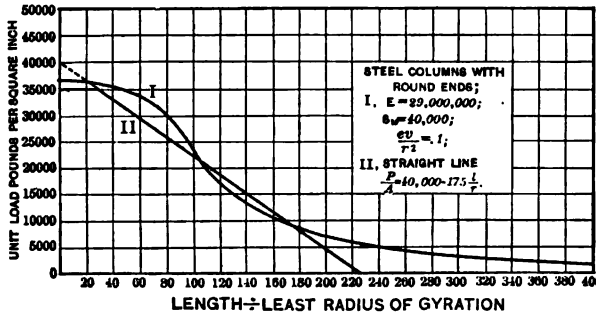

Fig. 153. — Straight Line and Secant Curves.

it pass through 40,000 on the Y axis. The horizontal line 35,000 is a little below curve I. (With a little greater eccentricity curve I would fall below 35,000.) With the eccentricity used, curve I falls above curve II for $\frac{l}{r}$ less than 110. For greater values of $\frac{l}{r}$ curve I is slightly below curve II.

PROBLEMS.

3. Calculate the total safe load by the American railway formula for a steel post 20 feet long made of one 8-inch by $\frac{1}{2}$ -inch plate and four 4-inch by 3-inch by $\frac{1}{4}$ -inch angles. (See Cambria.) *Ans.* 210,000 pounds.
4. Calculate the total safe load on a Z-bar column 16 feet long made of four 4-inch by 4-inch by $\frac{1}{2}$ -inch Z-bars and one 6 $\frac{1}{2}$ -inch by $\frac{1}{2}$ -inch web plate.
5. Using the result of Problem 1 of Article 115 for safe loads, design a square yellow-pine post 10 feet long to carry a total load of 18,000 pounds. *Ans.* 5.94 inches square; use 6-inch by 6-inch.
6. Using the same formula, find the thickness of a yellow-pine post 8 inches wide and 10 feet long to carry a total load of 28,000 pounds. *Ans.* 6.4 inches.
7. Solve Problem 6 for a load of 60,000 pounds. *Ans.* 11.8 inches.
8. Solve Problem 6 for a load of 1200 pounds, using the constants of Problem 1, Article 115. *Ans.* 2.06 inches thick.

9. Using the American railway formula, design a solid circular steel column to carry a total load of 60,000, the length of the column being 80 inches.

Ans. Diameter, 3 inches nearly.

10. What formula would you use for Problem 9 if the length were doubled?

117. Straight-line Formulas for Square or Fixed Ends. —

In applying straight-line formulas to columns with square or fixed ends, it is customary to *modify* the *constant* k and use the entire length of the column as l in the formula. The American Railway Engineering and Maintenance of Way Association uses the one constant (70) for all cases, treating the so-called fixed and square ends as no better than hinged ends. This is good practice for bridges and similar structures. When a bridge post is riveted to the floor beam, experiments show that the deflection of the beam often produces a bending stress in the post which is equivalent to a large eccentricity. In pin-connected bridges, a slight difference in the length of the eye-bars which form the diagonals of the truss sometimes causes such concentration of stress in one side of the post that it is weaker in the plane of the pins than perpendicular to that plane. In buildings, where the floor beams are riveted to the posts, there is likely to be considerable eccentricity in the end posts. At intermediate posts with beams on both sides the eccentricity is less.*

The American railway formula may well be used for all structures built of structural steel, provided, of course, due allowance is made for live loads and impact in computing the total load.

The building laws of New York city require for structural steel columns with square or fixed ends:

$$\frac{P}{A} = 15,200 - 58 \frac{L}{r}. \quad (1)$$

If we regard the length of the sine curve as 0.8 of the total length of the column, we get from the American railway formula $0.8 \times 70 = 56$. If k is 70 for round ends, and the effect of square or fixed ends is sufficient to make a 10-foot column equal in strength to an 8-foot round-end column, the constant 58 may be taken as practically correct for the square and fixed ends, if the total length of the column is taken as L (see experiments, Table IX).

* See paper by C. T. Morris, *Engineering News*, Nov. 2, 1911, p. 530.

In Problem 1 of Article 115, we found the formula

$$\frac{P}{A} = 1000 - 7 \frac{l}{r}, \quad (2)$$

for round-end columns of long-leaf yellow pine with a modulus of 1,500,000, an ultimate strength of 5000, with a factor of safety of 5. The New York building laws require

$$\frac{P}{A} = 1000 - 18 \frac{L}{D}. \quad (3)$$

For solid columns of circular section $D = 4 r$, so that equation (2) becomes

$$\frac{P}{A} = 1000 - 28 \frac{l}{D}. \quad (3)$$

If the ends of the square-end columns used in buildings are sufficiently well fixed that $9 L$ is equal to $14 l$, equations (2) and (3) are consistent.

The New York building formulas for timber posts are recommended for square- or fixed-end conditions. They may be applied to rectangular posts if D is taken as the least dimension.

PROBLEMS.

- 1. If cast iron has an ultimate strength in compression of 80,000 pounds per square inch and a modulus of 15,000,000, derive a formula for square-end cast-iron columns with a factor of safety of 8, assuming that the ends are so fixed that $3 L$ is equivalent to $4 l$. (Compare with Cambria.)
- 2. Find the total safe load by the New York building laws for a 12-inch 31.5-pound I-beam as a column with square ends, for lengths of 10 feet and 15 feet. *Ans.* 76,940 pounds and 45,040 pounds.
3. Find the total safe load on a 6-inch by 6-inch yellow-pine post 10 feet long by the New York building laws. *Ans.* 23,040 pounds.
- 4. Find the size of a square post of long-leaf yellow pine 10 feet in length, to carry a load of 40,000 in accordance with the requirements of the New York building laws. *Ans.* 7.49 inches square; use an 8-inch by 8-inch.
5. Solve Problem 4 for hemlock.
6. Find the total safe load by New York building laws on a column of medium steel made of two 9-inch 15-pound channels and two 13-inch by $\frac{1}{4}$ -inch plates, for lengths of 20 feet and 30 feet (see Cambria for constants). *Ans.* 255,900 pounds and 218,000 pounds.
7. Solve Problem 6 by the American railway formula.
- 8. Select a plate and channel column of medium steel, 20 feet in length, to carry a load of 100,000 in accordance with the New York building laws. (Use Cambria tables to get the column approximately and then apply the formula to see if the column thus selected will do.)
9. Solve Problem 8 by the American railway formula.

10. Select a plate and angle column 20 feet long, to carry 300,000 pounds safely in accordance with the American railway formula.

Ans. One 12-inch by $\frac{1}{2}$ -inch plate with four 6-inch by $3\frac{1}{2}$ -inch by $\frac{1}{2}$ -inch angles carries 316,000 pounds.

118. **Rankine's or Gordon's Formulas.**—While the straight-line formulas are coming into general use among engineers, on account of the ease of application and the fact that they agree as well with the results of tests as the more complicated expressions, another type of formula formerly had the preference and is still used considerably. This type is called Gordon's or Rankine's formula. It is an empirical formula which was first derived from the results of tests. It has the advantage that it applies to columns of any length. It is:

$$\frac{P}{A} = \frac{s_u}{1 + q \left(\frac{l}{r}\right)^2}, \quad \text{Formula XXVII.}$$

where s_u is the ultimate strength in compression in the case of a short block, and q is a coefficient determined from experiments with columns of various lengths. To use the formula with any given factor of safety, simply divide the numerator by the factor; that is, use the allowable unit stress instead as the ultimate strength.

The figures for structural steel columns with flat ends, given in Cambria, were computed by this formula, using 50,000 as s_u for medium steel and $\frac{1}{36,000}$ for q . (This value of q is the one recommended by Rankine.)

PROBLEMS.

1. Find the total load, with a factor of safety of 4, on a 12-inch 40-pound I-beam of medium steel, 12 feet in length, as a column with square ends.

Ans. 90,460 pounds.

$$\frac{1}{36,000} \left(\frac{l}{r}\right)^2 = 0.625; \quad \frac{P}{A} = \frac{12,500}{1 + 0.625}$$

Compare the results with Cambria, "Safe Loads for I-Beams used as Columns."

Using $s_u = 50,000$ and $q = \frac{1}{36,000}$, calculate the total load, with a safety factor of 4, on the following square-end columns of medium steel.

2. A 10-inch 25-pound I-beam 15 feet long.
3. A 12-inch 31.5-pound I-beam 16 feet long.
4. A 12-inch 31.5-pound I-beam 32 feet long.
5. A 6-inch by 4-inch by 1-inch angle 12 feet long.

6. A post made of two 10-inch 20-pound channels, latticed together 6 inches back to back, for lengths of 15 feet and 20 feet.

7. A column made of two 10-inch 15-pound channels, 9 inches back to back, and two 15-inch by $\frac{1}{4}$ -inch plates, for lengths of 20 feet and 40 feet.

119. Ritter's Rational Constant for Rankine's Formula. —

While the constant q was originally derived from a few tests of columns, it may be obtained from the constants of the materials. We know from experiments and theory that Euler's formula gives the ultimate load when the load is exactly central, the ends either perfectly free to turn or absolutely fixed, and the value of $\frac{l}{r}$ so great that the computed $\frac{P}{A}$ is below the true elastic limit of the material. Any curve which is to be used with all lengths must coincide with Euler's curve when $\frac{l}{r}$ becomes indefinitely large, and must also pass through the point s_u when $\frac{l}{r} = 0$.

We see that when $\frac{l}{r}$ equals zero, $\frac{P}{A}$ equals s_u ; Rankine's formula satisfies the second of the above-mentioned conditions. To make it satisfy the first condition, we must find some value of q which will make $\frac{P}{A}$ the same in Rankine's and Euler's formulas for large values of $\frac{l}{r}$:

$$\frac{P}{A} = \pi^2 E \left(\frac{r}{l}\right)^2 = \frac{s_u}{1 + q \left(\frac{l}{r}\right)^2} \quad (1)$$

For large values of $\frac{l}{r}$ the second term in the denominator of Rankine's formula is so large relatively that the first term (unity) may be dropped. Then

$$\frac{\pi^2 E}{\left(\frac{l}{r}\right)^2} = \frac{s_u}{q \left(\frac{l}{r}\right)^2} \quad (2)$$

$$q = \frac{s_u}{\pi^2 E} \quad (3)$$

This value of q is Ritter's rational constant.

PROBLEMS.

1. Find the value of q for steel having a modulus of 29,000,000 and ultimate strength, in compression, of 40,000 pounds per square inch. *Ans.* $\frac{1}{7155}$.

2. Using the ultimate strength of steel in compression as 40,000 pounds per square inch and the result of Problem 1 as q , find the ultimate loads in pounds per square inch for round-end columns for values of $\frac{l}{r}$, differing by 20, from 20 to 200.

<i>Ans.</i>	{	$\frac{l}{r}$,	20	40	60	80	100	120	140	160	180	200
		$\frac{P}{A}$,	37,900	32,700	28,600	21,100	16,700	13,300	10,700	8700	7200	6100

3. Solve for $\frac{P}{A}$ in Problem 2 by Euler's formula.

4. Using the constants of Problem 1, find the total safe load with a factor of safety of 4 on a round-end solid circular steel column 2 inches in diameter and 40 inches long. *Ans.* 16,600 pounds.

5. Using the constants of Problem 1, find the total load with a factor of safety of 5 which may be placed on a 10-inch 25-pound I-beam 10 feet long, used as a column with round ends. *Ans.* 18,800 pounds.

For the wrought iron used in Ritchie's experiments, Table IX, the modulus of elasticity was about 25,000,000 and the ultimate strength about 49,000. If we take E as 24,800,000, making $\pi^2 E = 245,000,000$, we get $\frac{1}{5000}$ as Ritter's constant for these experiments.

$$\frac{P}{A} = \frac{49,000}{1 + \frac{1}{5000} \left(\frac{l}{r}\right)^2} \quad (4)$$

gives the ultimate strength of wrought-iron struts with ends free to turn.

PROBLEMS.

6. Calculate $\frac{P}{A}$ for all values of $\frac{l}{r}$ from 0 to 400 at intervals of 20 by means of equation (4), and plot curve with abscissas 1 inch = $\frac{l}{r} = 40$; ordinates 1 inch = $\frac{P}{A} = 10,000$.

Also on the same sheet with the same origin and coördinates, plot the results of Table IX for round ends.

7. With $E = 24,800,000$, calculate $\frac{P}{A}$ by Euler's formula from $\frac{l}{r} = 60$ to 400 at intervals of 20, and plot the results with those of Problem 6.

COLUMN FORMULAS USED BY ENGINEERS 215

8. Draw straight line tangent to Euler's curve through the point (0, 49,000) and determine its equation. Compare this straight line with the results of the test.

9. With the results of Problems 6, 7, and 8 as a basis, write your conclusions as to the merits of Rankine's, Euler's, and the straight-line formulas.

Curve I of Fig. 154 is drawn from Rankine's formula with Ritter's constant calculated from $s_w = 40,000$ and $E = 29,000,000$, which makes $q = \frac{1}{7155}$. Curve II is Euler's. We see that curve I gradually approaches Euler's curve and is always on the

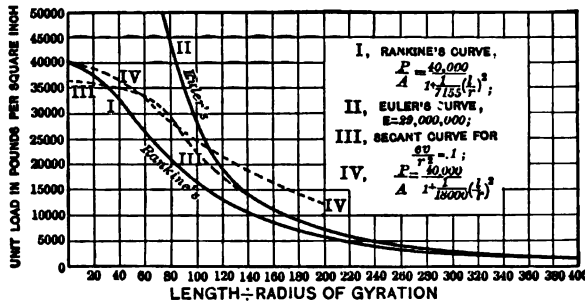

Fig. 154. — Column Curves.

safe side. Curve III is drawn from the secant formula for $\frac{e}{r} = 0.1$ (curve I of Fig. 145). We notice that curve I is

decidedly below curve III, especially for the values of $\frac{l}{r}$ between 40 and 120, which values are most used in actual columns. Rankine's formula with Ritter's constant gives correct values for very long columns and for columns of zero length with no eccentricity (these being the conditions under which the constants are determined), but for columns of the usual length is not so good as a straight line tangent to Euler's.

Curve IV is computed by means of Rankine's experimental constant $\frac{1}{18,000}$. It is not far off for short columns especially if the eccentricity is very small, but it is too high with columns which are relatively long.

Since the only advantage possessed by Rankine's formula over a straight-line formula is the fact that the former may be

used with columns of all lengths, it follows, that if it is used at all it should be used with Ritter's constant, so that the errors will be always on the safe side (except for very short posts). The experimental constants $\frac{1}{18,000}$ for hinged ends and $\frac{1}{36,000}$ for fixed ends which were recommended by Rankine are based on a limited number of tests. While they are not far off for short columns, these constants give unsafe results in relatively long ones.

The column tables in Cambria are computed with these constants. However, a larger factor of safety is taken than is used by many engineers, 12,500 being employed as the numerator for buildings and 10,000 recommended for bridges. On this account the results given are safe, and especially for values of $\frac{l}{r}$ less than 100.

In adapting Rankine's formula with Ritter's constant to fixed and square ends, the entire length L is used and q is modified. If the column were absolutely fixed at both ends, the q of Ritter's expression would be divided by 4; if q were $\frac{1}{7000}$ for round ends, it would be $\frac{1}{28,000}$ for ends rigidly fixed. In actual columns, since the ends are not perfectly fixed, we must use a ratio less than 4. Suppose that l is taken as $0.8 L$ (Table IX), then $l^2 = 0.64 L^2$. If we take q for structural steel as $\frac{1}{7155}$ (Problem 1),

$$\frac{l^2}{7155} = \frac{L^2}{11,200} \text{ nearly.}$$

The Philadelphia laws use, for medium steel:

$$\frac{P}{A} = \frac{16,250}{1 + \frac{L^2}{11,000 r^2}}. \quad (5)$$

A few years ago several railroads used the same formula with 17,000 as the numerator instead of 16,250. Both are rather high; 15,000 is better. This value of q is good for square ends where the eccentricity is small, but should not be used with pin ends except with a large factor of safety.

PROBLEMS.

10. Calculate the total safe load on a 4-inch by 4-inch by $\frac{1}{2}$ -inch angle of medium steel for lengths of 10 feet and 15 feet by the Philadelphia formula.
11. Compute the total safe load on a strut with flat ends, made of a 6-inch by 6-inch by 1-inch angle of medium steel, by the New York building laws, the Philadelphia building laws, and the American railway formula, for lengths of 10 feet and 15 feet.
12. Find the Z-bar column of medium steel 20 feet long with flat ends to carry a load of 400,000 pounds, by each of the formulas above mentioned.
13. Solve Problem 2 of Article 117 by the Philadelphia formula.
14. Find $\frac{P}{A}$ for medium steel for values of $\frac{l}{r}$ from 20 to 140 at intervals of 20, by the American railway formula, by the New York formula, and by the Philadelphia formula. Compare the results with those of Cambria for square ends with a factor of safety of 4.
15. Solve Problem 14 from 160 to 300 inclusive.

r20. General Conclusions. — The calculation of columns is not as satisfactory as that of beams. This is due to two reasons: the location of the load, and the relative freedom of the ends. In a beam, the location of the load is known with a large relative accuracy. A 1-inch displacement of the load in a horizontal beam 10 feet long produces a very small effect upon the unit stress; an equal displacement of the load at the end of a block 6 inches square will *double* the maximum stress on one face. Again, we generally deal with beams entirely free to turn at the supports or with cantilevers which are entirely free to move and turn at one end and which are perfectly fixed at the other, so far as concerns the moment arms. The results which we get in calculating beams are correct inside the true elastic limit and approximately true beyond that limit. If we take a column perfectly free to turn at both ends and know the position of the load with the same *relative* certainty as in the case of the beam supported at the ends, we may calculate the unit stress with the aid of Formula XXII as accurately as we can compute it in the beam by the use of Formula VIII. There is this apparent difference: in the beam the unit stress varies as the load; in the column it increases more rapidly. Again, a column fixed at one end and free at the other (case II, Fig. 146) can be calculated with the same accuracy as a cantilever with one end free, provided the load is located with the same relative accuracy and the end is so well fixed that the *relative* change in moment due to change in tangent at the "fixed end" is the same in both cases. The change in moment due to

change in the tangent at the ends is proportional to the rate of change of the cosine of a small angle in the case of a beam and to the rate of change of the sine of a small angle in the column. The loads being much greater in a column than in a beam of the same section, the effect of friction in partially fixing the ends is greater in the column.

Beams fixed at both ends or fixed at one end and supported at the other are indefinite, because it is not possible to fix the beam perfectly so that it will not turn, or support it so that it will not move. For these reasons the calculation of the unit stresses in relatively stiff beams of these kinds is always open to question. The same is true of columns fixed at both ends, or fixed at one end with a hinge connection at the other.

Euler's formula gives the ultimate load which will cause a column with practically no eccentricity to deflect without limit. Unless the column is relatively long, it will fail by crushing before this load is reached (see Fig. 145). *Euler's formula must never be used if the value of $\frac{P}{A}$ comes out greater than the elastic limit of the material.* It is better to use the results of Euler's formula only when they give $\frac{P}{A}$ less than one-third of the ultimate strength. In such case, divide the results by a suitable factor of safety to get the allowed load.

For shorter columns, draw a straight line tangent to Euler's curve and passing through the ultimate strength of the material on the Y axis. Divide the equation of this straight line by a suitable factor of safety for a working formula. Use this straight line to the ordinate of the point of tangency and use Euler's equation for the longer columns.

With hinged end columns the l of these formulas is the entire length between hinges. With case II, l is twice the length of the column. With fixed ends or with pin-and-square ends, it is also safest to take l as the entire length of the column. If any allowance is made, it should never be as great as that of the ideal cases, which are never met in practice. The amount of allowance depends upon the relative dimensions of the column and the beams to which it is attached and the method of attachment.

The effect of eccentricity is taken into account by using a

limiting stress for short columns, as in the case of the American railway formula, and by the use of a large factor of safety (well called a factor of ignorance) to take care of any uncertainties in this respect. (The real factor of safety in many columns which are standing is probably much less than figured by the designer.)

Rankine's formula is used by some engineers. With Ritter's constants it is always safe — unnecessarily safe for columns of moderate length. With Rankine's constants it should not be used for long columns.

If the eccentricity of the load were sufficiently well known, the secant formulas of Article 107 are strictly correct for round ends, below the true elastic limit. A set of curves like I and II of Fig. 145, for the different relative eccentricities, could be used for all cases of this kind.

121. **Failure of Beams Due to Flexure on the Compression Side.** — The compression flange of a beam is really a column, and may fail by buckling laterally. Fig. 155, II, is the plan of

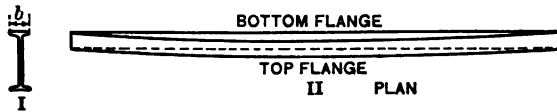

Fig. 155.

an I-beam supported at the ends. The top flange, being in compression, may buckle as shown, while the bottom flange remains straight. The unit stress in the top fibers computed as a

beam is the maximum value of the unit load $\frac{P}{A}$, of the column

theory. As only the very top fibers reach the maximum value of the stress, and as these fibers are held from buckling laterally by the fibers below, this unit load may be taken somewhat larger than in simple columns. Suppose we use 18,000 pounds per square inch as this maximum stress and use Rankine's formula

with the constant $\frac{1}{36,000}$ for fixed ends. If b is the breadth of

the flange, the square of the radius of gyration is $\frac{b^2}{12}$, and

$$\frac{P}{A} = \frac{18,000}{1 + \frac{l^2}{36,000 r^2}} = \frac{18,000}{1 + \frac{l^2}{3000 b^2}}$$

PROBLEMS.

1. If l is the length of the beam (or the distance between stiffeners) and 16,000 per square inch is the maximum compressive stress due to bending, find the maximum ratio of l to b in order that the flange will not buckle.

2. Solve Problem 1 if the maximum compressive stress due to bending is 12,000 pounds per square inch.

3. What is the maximum compressive stress allowable by the above formula if the stiffeners are placed at intervals of 60 times the breadth of the flange?

Compare the results of these problems with Cambria under "Lateral Strength of Beams without Lateral Support."

4. Solve Problem 2 by means of the American railway formula for columns instead of the one given above.

5. Using the New York formula, find the maximum compressive stress in a 15-inch 42-pound I-beam 10 feet long without stiffeners or other lateral supports. *Ans.* 10,840 pounds per square inch.

6. Using the American railway formula, find the maximum distance between stiffeners in an 18-inch 55-pound I-beam, when the maximum compressive stress due to bending is 13,000 pounds per square inch.

122. Failure Due to Buckling of the Web. — We learned in Article 31, that a vertical shear produces compression at 45

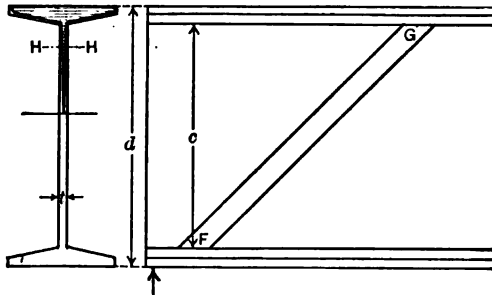

Fig. 156. — Web of I-Beam as a Column.

degrees to the vertical, and that the intensity of this compressive stress is equal to the unit vertical or horizontal shearing stress. All parts of the web of an I-beam subjected to vertical shear may be regarded as made up of a series of columns with fixed ends placed 45 degrees to the vertical. In Fig. 156, FG represents one such imaginary column. Small trusses are made similar to Fig. 157. The riveted diagonals such as CD and FG transmit the shear from the top to the bottom chord. FG is in compression and acts as a column. Instead of single bars

riveted at their intersections, a plate with part of the material cut away might be used to connect the top and bottom chords. Finally, if this plate is continuous it becomes a plate girder or I-beam.

Considering the column *FG* in Fig. 156, its thickness is *t*, the thickness of the web, and its length is $\sqrt{2} c$, where *c* is the distance between the flanges (represented by *l* in the Cambria sketches of I-beam sections). The unit shearing stress in the web varies slightly (see Article 84, Problems 9 and 10). It is customary to find the mean vertical shear in the web of an I-beam by dividing the total vertical shear by the area *td*, where *t* is the thickness of the web and *d* is the entire depth of the beam. Since unit compressive stress is equal to the unit shearing stress,

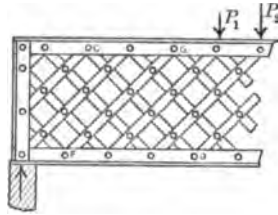

Fig. 157.

$$\frac{P}{A} = \frac{S}{td} \tag{1}$$

where $\frac{P}{A}$ is the unit load in the column formula and *S* is the total vertical shear. To find the safe value for *S*, it is only necessary to solve $\frac{P}{A}$ by any column formula, remembering that $r^2 = \frac{t^2}{12}$ for a rectangular section of thickness *t*. Using first Rankine's formula with 12,000 as the numerator and *q* equal to $\frac{1}{36,000}$ in order to compare with Cambria, we get:

$$\frac{P}{A} = \frac{12,000}{1 + \frac{t^2}{36,000 r^2}}; \tag{2}$$

$$\frac{P}{A} = \frac{12,000}{1 + \frac{1}{1500} \left(\frac{c}{t}\right)^2}. \tag{3}$$

PROBLEMS.

→1. Find the maximum value of the unit shear, the total vertical shear, and the total load uniformly distributed, on a 12-inch 31.5-pound I-beam, by means of the above formula.

Ans. 7488 pounds per square inch, 31,450 pounds, and 62,900 pounds.

2. Solve Problem 1 for a 15-inch 42-pound I-beam. Compare results with Cambria under "Maximum Loads of I-Beams and Channels Due to Crippling the Web."

3. If the allowable unit stress due to bending is 16,000 pounds per square inch, what is the minimum length for which the full bending stress may be developed by a uniformly distributed load without producing excessive buckling stresses in a 12-inch 31.5-pound I-beam?

4. Solve Problem 3 for a 20-inch 65-pound I-beam for the maximum load and minimum span without crippling the web if the load is concentrated at the middle.

5. Solve Problem 1 by the American railway formula.

Ans. Total load, 47,780 pounds.

6. Solve Problem 1 by the New York building laws.

Ans. 56,000 pounds.

7. Solve Problem 1 by the Philadelphia laws for medium steel.

Ans. 45,800 pounds.

Lewis P. McGilvary

Elect. Eng. 1916

CHAPTER XIV

TORSION.

123. **Torque.** — A shaft or rod subjected to a pair of equal and opposite couples in parallel planes at right angles to its length is in torsion between these planes. In Fig. 158 we have a rope wound around a shaft and carrying a weight. Attached to the shaft is a pulley upon which runs a belt. The tension on the rope and the reactions of the bearings form a counterclockwise couple, while the tension on the belt and the reactions form a clockwise couple. If there is no friction at the bearings, these couples are equal, provided the shaft is stationary or moving in either direction with constant speed. The moment of either couple is the *twisting moment*, or *torque*, in the portion of the shaft between the pulley and the rope. We will represent torque by M_t .

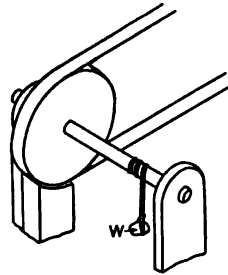

Fig. 158. — Shaft in Torsion.

PROBLEMS.

1. An axle 8 inches in diameter is used to lift a load of 400 pounds which is carried by a 1-inch rope. If the axle is turned by a crank at one end, what is the torque?

Ans. 1800 inch pounds.

2. A shaft carries a pulley 3 feet in diameter and a second pulley 2 feet in diameter. At the 2-foot pulley the belt runs horizontally to the right, with tension of 600 pounds in the upper portion and 100 pounds in the lower portion. The belt on the 3-foot pulley runs vertically downward, with tension of 120 pounds on the right portion. Find the torque between the pulleys and the tension on the left portion of the vertical belt.

Ans. 500 foot pounds, 453.3 pounds.

3. A bolt is turned by means of a wrench. The pull on the wrench is applied 16 inches from the axis of the bolt. Find the torque when the pull is 80 pounds.

Ans. 1280 inch pounds.

124. **Shearing Stresses in a Shaft.** — Let us consider a portion of the shaft of Fig. 158, between the pulley and the rope. Fig. 159 represents such a portion with axis vertical. We will

suppose the lower end to be stationary with respect to the upper end. When the shaft is twisted in a counterclockwise direc-

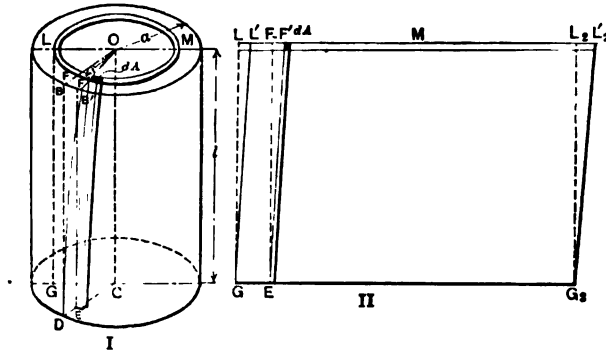

Fig. 159. — Portion of Shaft in Torsion.

tion, the plane $OBDC$ becomes the surface $OB'DC$, and the radius OFB remains a straight line $OF'B'$ (in case the section is circular). The displacement FF' of any point is proportional to its distance from the axis, and also proportional to its distance from the base regarded as stationary. Consider a hollow cylinder of radius $OF = r$, the upper base of which is the ring $LFML$. This cylinder developed gives the rectangle LGG_2L_2 of Fig. 159, II. When the shaft is twisted this developed cylinder becomes the parallelogram $L'GG_2L_2'$. Every filament as EF in the cylinder has suffered a shearing displacement FF' . Since $OF'B'$ remains straight, this displacement varies as r , and the unit shearing stress may be represented by kr , where k is the unit shearing stress at unit distance from the axis. On a filament of area dA , the total shearing stress is the area times the unit stress:

$$\text{Shear on } dA = kr dA. \quad (1)$$

The resisting moment of the shear on the filament EF' of area dA with respect to the axis of the cylinder OC is the product of the shear on the area multiplied by the radius:

$$\text{Resisting moment of filament} = kr^2 dA. \quad (2)$$

The total resisting moment of the entire portion, being the sum of the moments of all the filaments, is the integral of (2) over

the entire area of cross section, and is equal to the external torque.

$$\text{Torque} = k \int r^2 dA = kJ, \quad (3)$$

where J is the polar moment of inertia.

At a distance r from the axis,

$$s_s = kr;$$

$$k = \frac{s_s}{r}.$$

$$\text{Torque} = kJ = \frac{s_s J}{r};$$

$$s_s = \frac{\text{torque} \times \text{radius}}{\text{polar moment of inertia}}.$$

If a is the radius of the cylinder, the shearing stress in the outer fibers is given by

$$s_s = \frac{M a}{J}. \quad \text{Formula XXVIII.}$$

$$\left(\text{Compare with } s = \frac{Mv}{I}. \right)$$

PROBLEMS.

1. A 2-inch solid shaft is twisted by means of a pipe wrench. The force is 200 pounds applied 3 feet from the axis of the shaft. Find the maximum shearing stress. *Ans.* 4583 pounds per square inch.

2. A 6-foot flywheel is driven by a 4-inch solid shaft. The tension on the upper part of the belt running from the wheel is 1800 pounds and on the lower part it is 300 pounds. Find the torque and the maximum unit stress.

Ans. $s_s = 4298$ pounds per square inch.

3. Calculate the unit stress in a 2-inch solid shaft which is used to turn a drum 30 inches in diameter which is lifting 800 pounds by means of a 1-inch rope. *Ans.* 7894 pounds per square inch.

4. In Problem 2 what would be the unit stress if the shaft were hollow, inside diameter 2 inches, outside diameter 4 inches?

Ans. 4583 pounds per square inch.

5. Solve Problem 2 with the shaft hollow, inside diameter 2 inches, and outside diameter such that the weight per foot equals that of a 4-inch solid shaft.

6. In Problem 2, if the wheel makes 240 revolutions per minute, what is the horse power transmitted by the belt? *Ans.* 206 horse power nearly.

7. A 3-inch solid shaft running 250 revolutions per minute drives a wheel 4 feet in diameter. What is the difference in tension in the two parts of the

belt when the unit shearing stress is 4000 pounds per square inch? What is the horse power transmitted? *Ans.* 883 pounds; 85 horse power.

8. A key $\frac{3}{4}$ inch wide unites a 6-inch shaft to a flywheel. What must be the length of this key and the length of the hub of the wheel if the shearing stress in the key is equal to the maximum shearing stress in the shaft, no allowance being made for friction between hub and shaft?

Ans. 18.8 inches.

125. **Relation of Torque to Angle of Twist.** — In Fig. 159 the displacement FF' at a distance r from the axis of the shaft is $r\theta$, where θ is the angle FOF' . This angle θ is the displacement of the top plane with reference to the bottom. The unit displacement is the total displacement divided by the length of the portion:

$$\text{Unit displacement} = \frac{r\theta}{l}, \quad (1)$$

where l is the length of the portion considered. If E_s is the modulus of elasticity in shear,

$$\text{Unit shearing stress} = \frac{E_s r \theta}{l}. \quad (2)$$

$$\text{Resisting moment} = \frac{E_s r^2 \theta}{l} dA. \quad (3)$$

Total resisting is the integral of (3) over the entire section, remembering that θ is constant for any given value of l :

$$M_t = \frac{E_s \theta}{l} \int r^2 dA = \frac{E_s \theta J}{l}; \quad (4)$$

$$\theta = \frac{M_t l}{E_s J}. \quad \text{Formula XXIX.} \quad (5)$$

This theory applies rigidly to circular shafts only. For other sections the deformations and stresses are not exactly proportional to the distance from the axis.

PROBLEMS.

1. A 4-inch solid steel shaft is twisted 2 degrees in a length of 12 feet. If the modulus of shearing elasticity is 12,000,000, what is the torque?

Ans. 73,100 inch pounds.

2. In Problem 1 what is the unit shearing displacement of the extreme fibers and what is the unit stress?

Ans. $s_s = 5818$ pounds per square inch.

This problem should be solved from the geometry of the shaft without using the formulas of this and the preceding articles.

3. A 2-inch solid shaft is twisted 3 degrees in a length of 5 feet by a force of 300 pounds applied at the ends of a lever 48 inches long. Find E_s .

4. When a shaft of radius a and length l is twisted an angle of θ radians, show from Fig. 159, without integrating, that

$$s_s = \frac{E_s a \theta}{l},$$

and from this result by means of Formula XXVIII derive Formula XXIX.

126. Relation of Torque to Work. — It is often convenient to use the relation of torque to foot pounds of work per revolution. If a force P is applied at the end of an arm R feet in length measured from the axis of the shaft, the work per revolution is $2\pi RP$ foot pounds, since the force P displaces its point of application a distance $2\pi R$. But since PR is the torque, the work per revolution is $2\pi M_t$.

In all problems involving work done by a shaft, solve first for the torque. When the torque is obtained in a numerical or literal equation, it may be used in Formulas XXVIII or XXIX.

PROBLEMS.

1. A shaft transmits 300 horse power at 200 revolutions per minute. What is the torque in foot pounds? *Ans.* 7875 foot pounds.

2. In Problem 1 what must be the diameter of the shaft if the maximum unit shearing stress is 4000 pounds per square inch? *Ans.* 4.93 inches.

3. Find the diameter of a solid shaft to transmit 1200 horse power at 150 revolutions per minute with a maximum shearing stress of 6000 pounds per square inch. *Ans.* 7.54 inches.

4. A shaft coupling is made of two disks fastened together by six 1-inch bolts. The axis of each bolt is 8 inches from the axis of the shaft. What horse power will the coupling transmit if the allowable unit shearing stress in the bolts is 9000 pounds per square inch?

Ans. 323 times the number of revolutions per second.

127. Torsion Combined with Bending or Tension. — In beams the maximum bending stress exists in the upper and lower fibers, while the maximum shearing stress is at the neutral surface, so that the resultant is seldom much greater than the maximum values of the separate stresses. On the other hand, in shafting subjected to bending and twisting, the maximum shearing stress is in the outer fibers, while the maximum tensile stress due to bending comes in some of these same fibers, so that the resultant is much larger than either stress. A similar condition exists when torsion is combined with direct tension or compression.

PROBLEMS.

1. A 1-inch round rod projects from a vise. A wrench is applied to the rod 8 inches from the vise, and a force of 60 pounds is applied to the wrench 12 inches from the axis of the rod. Find the unit tensile stress due to bending at the vise (Fig. 160). Find the unit shearing stress due to twisting in all the outer fibers.

$$\text{Ans. } \begin{cases} s_t = \frac{3840 \times 4}{\pi} = 4889 \text{ pounds per square inch;} \\ s_s = \frac{3840 \times 3}{\pi} = 3667 \text{ pounds per square inch.} \end{cases}$$

2. In Problem 1 find the maximum resulting tensile and shearing stress.

$$\text{Ans. } s'_t = 1222 \sqrt{3^2 + 2^2} = 4407 \text{ pounds per square inch;} \\ s'_s = 2444 + 4407 = 6851 \text{ pounds per square inch.}$$

Observe since the section modulus used in torsion is twice that used in bending and the load is the same for both, there is always a large common factor which may be taken out to reduce the work.

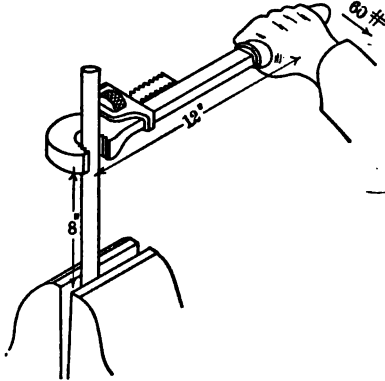

Fig. 160. — Torsion and Bending.

3. If the rod in Problem 1 were twisted by two wrenches extending in opposite directions with equal forces of 30 pounds on each, what would be the maximum resultant stress?

4. A 3-inch solid shaft is supported on bearings 4 feet apart. It carries a 3-foot pulley 1 foot from the left bearing and a 2-foot pulley 1 foot from the right bearing. The 3-foot pulley weighs 200 pounds and the 2-foot pulley weighs 150 pounds. The belts run vertically downward. The tension on the front on the 3-foot pulley is 500 pounds and on the back 120 pounds. The tension on the front on the 2-foot pulley is 160 pounds. Find the tension on the back on the 2-foot pulley and the horse power transmitted at 300 revolutions per minute, assuming that there is no friction.

Ans. 32.6 horse power.

5. In Problem 4 find the maximum resultant shearing and tensile stress at the middle of the span, neglecting the weight of the shaft.

Ans. 2469 pounds per square inch; 4574 pounds per square inch.

6. In Problem 4 find the resultant tensile and shearing stress 18 inches from the left bearing.

7. Solve Problem 5 if the belts on the 3-foot pulley run horizontally backwards, all other factors remaining the same.

8. A 4-inch vertical shaft is subjected to a direct compression of 6000 pounds and a twisting moment due to a force of 600 pounds at the end of a 4-foot lever. What is the resultant compressive stress in the outer fibers?

Ans. 2543 pounds per square inch.

128. **Helical Springs.** — An interesting example of torsion is the stretching or compression of a helical spring, such as is shown

in Fig. 161. A helical spring is made by winding a wire or rod on a cylinder (in a single layer, usually). The radius of the coil of the spring is the sum of the radii of wire and the cylinder about which it is wound. The ends of the wire, when the spring is to be used in tension, are turned in to the center so as to apply the force in the line of the axis.

The greater part of the elongation of a helical spring is due to torsion. If we consider a section at O , Fig. 161, II, we find that there is a twisting moment PR due to the load P at the axis. (Fig. 161, II, is a plan of the lower turn; the force P is normal to the plane of the paper.) The point C at which the load P is applied being at the center of the circle, it lies in the plane of the section and therefore there is no bending moment. The effect of a force acting on an arm CBO is independent of the form of the arm. As far as concerns the stresses at the section, CBO might be a straight rod from C to O . The point O is any point in the spring except the portion CB and the similar portion at the top. With these exceptions the entire spring is subjected to a twisting moment PR . In addition to this torsion, there is a constant total shear P . Also, since the turns of the coils are not exactly horizontal, there is another slight correction. Both of these are neglected in ordinary calculations.



Fig. 161.
Helical Spring.

To get the elongation of a helical spring due to a given load, multiply the angle of twist in the entire spring by the radius R .

PROBLEMS.

1. A rod 0.4 inch in diameter is used to make a helical spring of 20 turns. The radius from axis of coil to center of all sections is 2 inches. If E_s is 12,000,000, find the elongation due to a load of 10 pounds. *Ans.* $\frac{1}{3}$ inch.
2. In Problem 1 what is the unit shearing stress in the outer fibers?
Ans. 1591 pounds per square inch.
3. If the same length of rod were used to make 40 turns of 1-inch radius, what would be the elongation due to a load of 10 pounds? *Ans.* $\frac{1}{2}$ inch.
4. What is the unit stress in Problem 3?
5. A wire 0.1 inch in diameter is bent into 40 turns of a helical spring of 0.5-inch radius. If E_s is 12,000,000, how much will a load of 1 pound elongate this spring? *Ans.* $\frac{1}{5}$ inch.

6. How many turns of wire are required to make a spring similar to that of Problem 5 which a load of 1 pound will elongate 1 inch?

7. If R is the radius of the helix, r the radius of the rod, P the load, E_s the modulus of elasticity in shear, and n the number of turns, prove that the elongation is

$$\frac{4PR^3n}{E_s r^4}$$

8. At Watertown Arsenal, a steel rod 1.24 inches in diameter and about 241 inches long was formed into a helical spring 7.64 inches *outside* diameter. A load of 5000 pounds shortened this spring 4.64 inches. Find the modulus of shearing elasticity. Ans. 11,460,000.

9. Derive an expression for the elongation of a helical spring which shall contain the total length of the rod or wire instead of the number of turns.

Lewis P. McGilvary
Elect. Eng. 1916

CHAPTER XV.

RESILIENCE IN BENDING AND TORSION.

129. **Resilience in Beams.**— In Article 12 we learned that the elastic resilience per cubic inch is $\frac{s^2}{2E}$, and that the total energy is this quantity multiplied by the volume. In beams the same relation holds, but the stress varies from the neutral axis to the outer fibers, and also varies with the moment from one end to the other.

We may calculate the total energy in either of two ways: we may find the total work done by the external forces, or we may

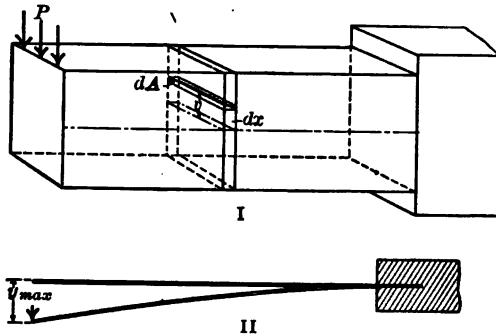

II
Fig. 162.

derive an expression for the internal work in each increment of volume and integrate over the entire volume of the beam.

By external work, if a load P causes a deflection y_{max} at its point of application, the work is $\frac{Py_{max}}{2}$ (Fig. 162, II). In a beam with a single concentrated load, if we find the deflection under the load for any particular case, the total work is easily calculated. In a cantilever with a load on the end, the deflection at the end is

$$y_{max} = \frac{Pl^3}{3EI},$$

and the work done by the load P is

$$\text{Work} = \frac{P^2 l^3}{6 EI} \quad (1)$$

Where the load is uniformly distributed, w pounds per unit length, each increment of load $w dx$ on a length dx does work amounting to $\frac{wy dx}{2}$, where y is the deflection of the particular part of the beam on which the increment rests. In Fig. 163, II, one increment $w dx$ is deflected a distance y_1 , another, y_2 , etc.

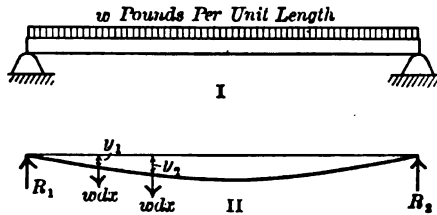

Fig. 163.

The different values of y are determined from the equation of the elastic line. The total work is the sum of these increments of work.

$$\text{Total work} = \frac{w}{2} \int y dx, \quad (2)$$

with the ends of the beam as the limits.

130. Expression for Internal Work.— In a beam the unit stress at a distance v from the neutral axis is $\frac{Mv}{I}$. In Fig. 162, I, there is an element of volume of cross section dA and length dx at a distance v from the neutral axis. The energy dW in this element of volume $dA dx$ is

$$dW = \frac{s^2}{2 E} dA dx = \frac{M^2 v^2}{2 EI^2} dA dx. \quad (1)$$

$$\text{Total work in beam} = \int \int \frac{M^2}{2 EI^2} v^2 dA dx. \quad (2)$$

Integrating first with respect to v gives the work done upon the volume of length dx between two vertical planes. Throughout

this volume x , M , and I are constant. The integral of $v^2 dA$ across the beam from the bottom to the top is I .

$$\text{Work} = \int \frac{M^2}{2 EI} dx. \tag{3}$$

Equation (3) enables us to calculate the total work for any beam. M and I are expressed in terms of x before integrating.

131. **Cantilever with Uniformly Distributed Load.** — The moment is $\frac{wx^2}{2}$, if the origin is taken at the free end.

$$\text{Total work} = \int \frac{w^2 x^4}{8 EI} dx. \tag{1}$$

For a beam of constant cross section for which I is constant,

$$\text{Total work} = \frac{w^2 l^5}{40 EI} = \frac{W^2 l^3}{40 EI}. \tag{2}$$

In a rectangular section the maximum fiber stress at the wall is given by

$$\begin{aligned} \frac{Wl}{2} &= \frac{2 s I}{d}, \\ W^2 l^2 &= \frac{16 s^2 I^2}{d^2}. \end{aligned} \tag{3}$$

Substituting in (2):

$$\begin{aligned} \text{Work} &= \frac{4 s^2 l I}{10 d^2 E} = \frac{s^2 b d l}{30 E}, \\ \text{Work per unit volume} &= \frac{s^2}{30 E}. \end{aligned} \tag{4}$$

The total energy in a cantilever of uniform rectangular section is only one-fifteenth as much as that in a block of the same volume with constant compressive stress throughout.

PROBLEMS.

1. Find the expression for the work per unit volume in a solid circular cantilever with a uniformly distributed load, in terms of the maximum fiber stress. Ans. $\frac{s^2}{40 E}$.

2. Find the total work in a cantilever of uniform section by means of the external work, using the expression of Article 129.

3. By the method of internal work find the total work done by a load at the end of a cantilever. Compare the result with equation (1), Article 129.

4. Find the work per unit volume in a cantilever with a load on the end, if the section is rectangular. Ans. $\frac{s^2}{18 E}$.

5. Find the energy per unit volume in a cantilever of uniform circular section with load on the end. Ans. $\frac{s^2}{24 E}$.

6. Show that the energy per unit volume in the case of a beam supported at the ends with a load at the middle is the same as that of a cantilever with a load on the end.

7. Find the work per unit volume in a beam of rectangular section supported at the ends and uniformly loaded.

$$\text{Ans. Total work} = \frac{W^2 l^3}{240 EI} \text{ for any section;}$$

$$\text{Work per unit volume for rectangular section} = 4 \frac{s^2}{45 E}$$

132. Beams of Variable Section. — In beams of variable section the moment of inertia is a variable. Take the case of a cantilever beam of constant strength and constant depth d with a load on the free end. If B is the breadth at the wall, Fig. 164, the breadth at a distance x from the free end is $\frac{Bx}{l}$.

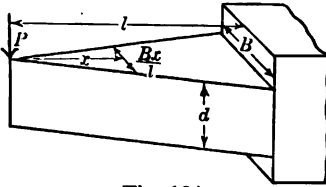

Fig. 164.

$$I = \frac{Bxd^3}{12l}. \quad (1)$$

$$M = Px$$

$$\text{Total work} = \int_0^l \frac{6 P^2 l^2 x}{EBd^3} dx = \frac{3 P^2 l^3}{EBd^3}. \quad (2)$$

Since $6 Pl = sBd^2,$

$$\text{Total work} = \frac{s^2 Bdl}{12 E} = \frac{s^2}{6 E} \text{ volume}. \quad (3)$$

PROBLEMS.

1. From equation (2) find the deflection at the end of a cantilever of constant strength and constant depth with a load at the end. Compare result with Article 95.

RESILIENCE IN BENDING AND TORSION 235

2. Find the total resilience and the energy per unit volume in a cantilever of constant breadth and constant strength with a load on the free end.

Ans. Total work = $\frac{s^2 b D l}{9 E}$;

Work per unit volume = $\frac{s^2}{6 E}$.

3. By means of the external work and the total work of Problem 2, find the deflection at the end of a cantilever of constant strength and constant breadth due to a load at the end.

133. Leaf Springs.— The common leaf springs as used in vehicles are beams of constant strength made of several parts or leaves. Fig. 165, II, shows a spring of this kind. Fig. 165, I, represents the leaves straight with a little distance between them. In the upper beam the moment is constant from *A* to *B*. In the second beam it is constant from *C* to *D*.

With a constant moment *M* the energy is

$$\int \frac{M^2}{2 EI} dx = \frac{M^2 l}{2 EI}, \quad (1)$$

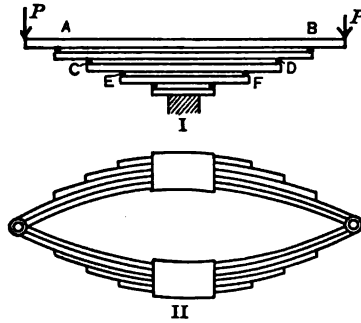

Fig. 165. — Leaf Spring.

if *l* is the length from the points of support (*A* and *B* for the top leaf).

$$\text{Energy} = \frac{2 s^2 I l}{E d^2} = \frac{s^2 b d l}{6 E}, \quad (2)$$

for a rectangular section.

Since *bdl* is the volume between supports, the energy for the portion having constant moment is $\frac{s^2}{6 E}$ per unit volume. This is the same as in the rectangular beams of constant strength in the preceding article.

The portions of the top leaf to the left of *A* and to the right of *B* are cantilevers with load on the end, and store only one-third as much energy per cubic inch as the portion between *A* and *B*. In the actual leaf spring as shown by Fig. 165, II, the contact

takes place over a considerable area and the stresses are somewhat modified by the friction.

134. Resilience in Torsion. — The work done by a force P at the end of an arm of length R when the arm is turned through an angle θ is

$$\frac{PR\theta}{2} = \frac{M_t\theta}{2}, \quad (1)$$

provided the force is applied gradually.

If we substitute in (1) the values of M_t and θ from Formulas XXVIII and XXIX, we get for a rod of length l and radius r ,

$$\text{Total work of torsion} = \frac{s_s^2 J l}{2 E_s r^2} = \frac{s_s}{4 E_s} \text{ volume.} \quad (2)$$

The modulus of elasticity in shear is about two-fifths as great as in tension or compression, so that for the *same value* of the unit stress the total energy of a rod in torsion is one-fourth greater than that of the same rod in tension. However, since the elastic limit of steel and similar materials is less in shear than in tension, the total energy which can be stored is about the same in both cases.

Since torsion gives so much more energy than bending, it is to be preferred in the design of springs. A helical spring in which the stresses are chiefly torsional is the most convenient form to take up energy.

PROBLEMS.

1. In Problem 8 of Article 128 find the total work in compressing the spring, and the energy per cubic inch and per pound.

Ans. Total energy, 966.7 foot pounds.

2. A spring at the Watertown Arsenal was made of 36 pounds of steel rod 1.02 inches in diameter. The outside diameter of the coil was 4.30 inches. A load of 11,000 pounds changed the length of this spring from 20.63 inches to 16.67 inches. After the load was removed the spring returned to its original length to within 0.02 inch. Find the energy per cubic inch and the energy per pound.

Ans. 50.4 foot pounds per pound.

3. In Problem 2 what was the maximum shearing stress due to torsion?

Ans. 86,580 pounds per square inch.

135. Sections of Maximum Resilience. — To obtain the maximum resilience per unit volume, the stress in all portions of the solid should be the maximum allowable stress. We can only secure this condition of perfect efficiency when the material is used in direct tension or compression, which is not practicable

in the construction of springs on account of the small displacement secured and the large force required (except in the case of soft rubber).

In bending and torsion only the outer fibers are subjected to the maximum stress, so that the energy per unit volume is always less than $\frac{s^2}{2E}$.

In any section subjected to bending the unit stress = kv , and the total energy in a portion of length dx , extending from the neutral surface to the outer fibers at a distance v_1 from this surface, is

$$\frac{k^2 dx}{2E} \int_0^{v_1} v^2 dA. \tag{1}$$

For a rectangular section of breadth b this becomes

$$\frac{k^2 b dx}{2E} \int_0^{v_1} v^2 dv = \frac{k^2 b v_1^3 dx}{6E}. \tag{2}$$

Since $kv_1 = s$ and $bv_1 dx =$ the volume, we get

$$\text{Energy per unit volume} = \frac{s^2}{6E}.$$

In a solid rectangular section used as a beam of constant strength or as a beam of uniform section with a constant moment, the efficiency as a spring is one-third.

In an I-beam section a relatively large portion of the section is in the flange, where the unit stress approximates the maximum, so that the energy per unit volume is greater than in the rectangular section.

In a circular section which is twisted an angle θ in a length l the unit deformation at a distance r from the axis is $\frac{\theta r}{l}$, and the shearing force on a circular element of radius r and thickness dr is $\frac{2\pi E_s \theta r^2 dr}{l}$. The energy, being one-half the product of the force by the deformation, is $\frac{\pi E_s \theta^2 r^3 dr}{l}$.

$$\text{Total energy} = \frac{\pi E_s \theta^2 [r^4]_0^a}{4l} = \frac{\pi E_s \theta^2 (a^4 - b^4)}{4l}, \tag{3}$$

where b is the inside radius and a is the outside radius. At the outer fibers $s_e = \frac{E_e a \theta}{l}$, which substituted in (3) gives

$$\text{Total work} = \frac{s_e \pi l (a^2 - b^2) (a^2 + b^2)}{4 E_e a^2} = \frac{(a^2 + b^2) s_e^2}{4 a^2 E_e} \times \text{volume.} \quad (4)$$

PROBLEMS.

1. Show that (4) reduces to (2) of Article 134 when $b = 0$.
2. What is the energy per unit volume in a hollow cylinder whose inside diameter is one-half its outside diameter? *Ans.* $\frac{5 s_e^2}{16 E_e}$
3. A hollow rectangular beam is 6 inches by 8 inches outside, and 4 inches by 4 inches inside. Find its energy per unit volume if the external moment is constant throughout its length. *Ans.* $\frac{11 s^2}{48 E}$

Lewis P. McGilvary
Elect. Eng. 1916

CHAPTER XVI.
CENTER OF GRAVITY.

136. Center of Gravity.— When each of the particles which compose a body or system of bodies is subjected to a force which is proportional in magnitude to the mass of the particle and parallel to the similar forces in every other particle, the line of application of the resultant of these forces passes through the *center of gravity* of the body or system.

The location of the center of gravity is determined from the intersection of two such resultants.

Fig. 166 represents three particles of relative masses 2, 3, and 4, united by weightless rods to form a single body. In

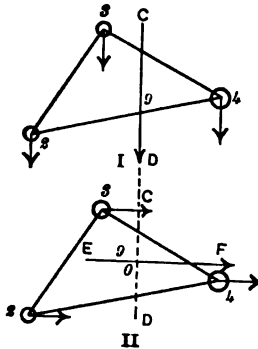

Fig. 166.

Fig. 166, I, these particles are subjected to forces directed vertically downwards. The resultant of these forces is a force of 9 units along the line CD . The center of gravity is located at some point on this line. In Fig. 166, II, the forces are horizontal, and their resultant is a horizontal force of 9 units along the line EF . The point O at the intersection of EF with CD is the center of gravity.

The center of gravity is also called the *center of mass*.

137. Determination of the Center of Gravity by Balancing.— The force with which the earth attracts the particles of a body is proportional* to the mass of each particle. These forces are

* There is a difference in the attraction of the earth due to difference in the distance of the various particles from the center of the earth amounting

directed toward the center of the earth, so that for bodies of ordinary dimensions they may be regarded as parallel, within the limits of accuracy of our measurement. The resultant force of gravity on any body passes through the center of gravity. A body may be held in equilibrium by a single force provided that force is along the line of the resultant of all the other forces.

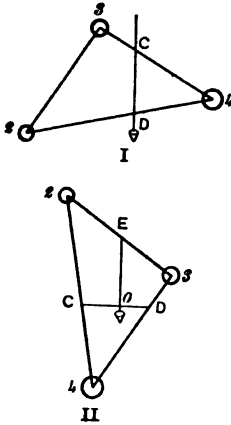

Fig. 167. — Location of Center of Gravity.

When a body is supported by a flexible cord or by a point about which it is free to turn without friction, the center of gravity must be on the vertical line through the point of application of the cord or point (provided, of course, no forces are acting except gravity and the cord or point).

Fig. 167 shows the same body as Fig. 166. In Fig. 167, I, it is supported at *C* by a cord. A plumb line let fall from *C* passes through the center of gravity. In Fig. 167, II, it is supported on a point or knife edge at *E*, and turns under the action of gravity until its center of gravity comes directly below the point of support. The intersection of the plumb line from *E* with the line

CD (previously marked in any convenient way) gives the center of gravity *O*.

This method of finding the location of the center of gravity is of little practical use, owing to the fact that the point to be found is usually surrounded by solid material, making it necessary to find the intersection of three planes instead of the intersection of two lines. It is useful in relatively long bodies, especially if there are some plane surfaces to use as planes of reference. Fig. 168 represents a beam balanced on a knife edge.



Fig. 168. — Center of Gravity by Balancing.

138. Center of Gravity by Moments. — In theoretical discussions the center of gravity is usually located by moments. The plane of application of the resultant of any set of forces

to about one part in ten million for a difference of one foot. This is negligible for ordinary bodies. It would not be negligible in the case of a mountain.

can be determined by dividing the sum of the moments of all the forces with respect to any axis by the magnitude of the resultant force. This comes from the proposition of Mechanics that the sum of the moments of any set of forces with respect to any axis is equal to the moment of their resultant with respect to that axis.

Fig. 169 represents a body made up of four particles of masses m_1, m_2 , etc., which are not all in one plane. The X axis is taken in the usual way; the Y axis is vertical as in the analytics of two dimensions; and the Z axis is horizontal with the positive direc-

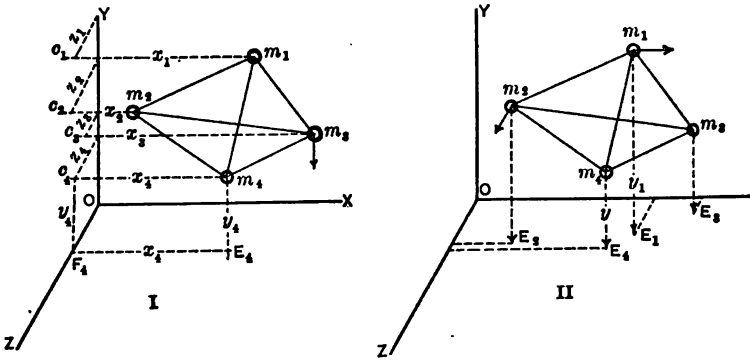

Fig. 169. — Center of Gravity by Moments.

tion toward the front. In Fig. 169, I, the coördinates of the particles in the direction of the Z axis are drawn in the YZ plane; the Y coördinates are in the Y axis; the X coördinates are perpendiculars let fall from the points m_1, m_2 , etc., upon the YZ plane.

We will first take moments about the Z axis, and we will consider that the letters m_1, m_2 , etc., represent relative masses as well as the positions of the particles. If the forces which act on these particles are vertically downward, the moment arm of each force is the x of the particle. In the case of m_4 , for instance, the force is directed toward the point E_4 in the XZ plane; its moment arm is the line F_4E_4 which is equal in length to x_4 . The total moment of all these vertical forces is given by

$$\text{Total moment} = m_1x_1 + m_2x_2 + m_3x_3 + m_4x_4. \quad (1)$$

The total force is the sum of the separate forces, since they are all parallel.

The coördinate of the center of gravity, represented by x , is

$$\bar{x} = \frac{m_1x_1 + m_2x_2 + m_3x_3 + m_4x_4}{m_1 + m_2 + m_3 + m_4}. \quad (2)$$

Since the forces are parallel to the YZ plane, if we used any axis in that plane parallel to the Z axis, the moment arms would remain the same, consequently we are accustomed to speak of the moments in (1) as the *moments with respect to the YZ plane*.

Equation (2) is the equation of a plane normal to the X axis, which passes through the center of gravity. To locate the point we must get the equations of two other planes.

If we were endeavoring to measure \bar{y} (the distance of the center of gravity above the XZ plane) experimentally, it would be necessary to rotate the entire system 90 degrees, so as to make the Y axis horizontal and give an effective moment arm to the forces. In a theoretical calculation, we may *imagine* the forces turned 90 degrees. In Fig. 169, II, the force upon m_1 is drawn parallel to the X axis and we will suppose that all the other forces are in the same direction. The moment arm of the force m_1 with respect to the Z axis is the line m_1E_1 which is y_1 . Instead of using the Z axis we might use any line in the XZ plane parallel to the Z axis as the axis of moments. It is not necessary that the forces be parallel to the X axis as they may be parallel to the Z axis shown in Fig. 169, II, at m_2 , in which case the axis of moments is some line in the XZ plane parallel to the X axis; or the forces may be in any direction parallel to the XZ plane. When we think of a moment with respect to a plane we do not generally consider the direction of the forces, but concern ourselves only with their magnitude and the distance from the plane of reference.

$$\bar{y} = \frac{m_1y_1 + m_2y_2 + m_3y_3 + m_4y_4}{m_1 + m_2 + m_3 + m_4}. \quad (3)$$

A similar expression gives z , the moments being taken with respect to the XY plane.

To get the distance of the center of gravity of a body from any plane, divide the sum of the moments of all the particles which compose the body with respect to the plane, by the total mass of the body.

PROBLEMS.

1. A body is composed of three particles in the same plane

Mass	<i>x</i>	<i>y</i>
3	5	7
2	4	8
5	3	6

Find \bar{x} and \bar{y} .

$$\bar{x} = \frac{3 \times 5 + 2 \times 4 + 5 \times 3}{3 + 2 + 5} = \frac{38}{10} = 3.8,$$

$$\begin{array}{r} 3 \times 7 = 21 \\ 2 \times 8 = 16 \\ 5 \times 6 = 30 \\ \hline 10 y = 67 \\ \bar{y} = 6.7 \end{array}$$

The second form of solution is preferable, especially when the numbers are large. It is still better to arrange the data and results in a single table omitting the multiplication and equality signs.

2. A body is composed of four particles of the following masses and coördinates.

Mass	<i>x</i>	<i>y</i>	<i>z</i>	<i>mx</i>	<i>my</i>	<i>mz</i>
3	5	4	3			
5	2	6	5			
6	4	-2	8			
2	3	9	4			

Ans. $\bar{y} = 3$, etc.

139. Center of Gravity of Continuous Bodies. — When a body is made up of a great number of particles m_1, m_2 , etc., at distances x_1, x_2 from the *YZ* plane, the expression for the moment with respect to the plane is written Σmx , and the position of the center of gravity is given by

$$x = \frac{\Sigma mx}{\Sigma m} = \frac{\Sigma mx}{M}. \tag{1}$$

When the number of particles is indefinitely great and their magnitudes indefinitely small we write

$$\bar{x} = \frac{\int x dM}{\int dM} = \frac{\int x dM}{M}. \quad \text{Formula XXX.}$$

If dV is an element of volume and ρ is the density, $dM = \rho dV$.
If ρ is constant, Formula XXX becomes

$$\bar{x} = \frac{\rho \int x dV}{\rho \int dV} = \frac{\int x dV}{\int dV} = \frac{\int x dV}{V}. \quad (3)$$

In these expressions, x is the distance of the *center of gravity* of the *element of mass* from the YZ plane. If the dimension of the element of volume parallel to the X axis is infinitesimal (dx) and the origin of moments is taken in the YZ plane, the " x " in the expressions above is the x of the Cartesian coördinates. Where the element of volume has a finite length in the direction parallel to the X axis, this is not the case, as will be seen in some of the examples.

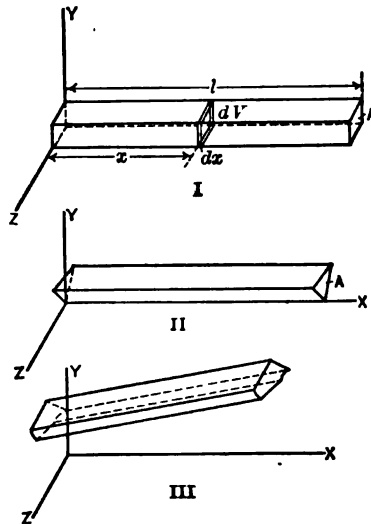

Fig. 170. — Center of Gravity of a Prism.

PROBLEMS.

1. Find the center of gravity of a rod of uniform section and density, using the plane of one end as the YZ plane.

If A is the area of any cross section parallel to the ends, Fig. 170, I,

$$dV = A dx,$$

$$\bar{x} = \frac{A \int x dx}{A \int dx} = \frac{A \left[\frac{x^2}{2} \right]_0^l}{A [x]_0^l} = \frac{\frac{Al^2}{2}}{Al} = \frac{l}{2}.$$

The constant term A might have been canceled before integrating; but it is best to retain all such constants until the limits are put into the integrals. The denominator of the fraction is the volume of the solid, which we know in many cases, so that if no constant terms are dropped we are enabled to check that much of our work.

Fig. 170, I, is a rectangular parallelepiped, but there is nothing in the work which limits us to a rectangular section. The results apply to right prisms of any section whatever (Fig. 170, II). Nor are we limited to *right* prisms. Fig. 170, III, shows an oblique prism with one end in the YZ plane and the other end parallel to this plane and with all sections alike. The center of gravity of this prism lies in a vertical plane midway between the planes of the ends.

2. Solve Problem 1 with the XZ plane (and the origin of coördinates) at the middle of the length of the prism.

140. Center of Gravity of Plane Areas. — A plane area may be regarded as a plate of *uniform thickness* t and *uniform density*. If the faces of this plate are parallel to the XY plane

$$\bar{x} = \frac{t \int x dA}{tA} = \frac{\int x dA}{A}, \tag{1}$$

where dA is an element of area and A is the entire area of the surface.

$$\bar{y} = \frac{\int y dA}{\int dA}. \tag{2}$$

PROBLEM.

1. Find the center of gravity of a triangular area, of base b and altitude h , by integration. We will take the origin at the vertex C and so place the base ED of length b that it shall be parallel to the Y axis. The element of area is a strip of width dx . From similar triangles, the length of this strip FF' is $\frac{bx}{h}$.

$$\begin{aligned} dA &= \frac{bx}{h} dx; \\ \bar{x} &= \frac{\frac{b}{h} \int x^2 dx}{\frac{b}{h} \int x dx} = \frac{\frac{b}{h} \left[\frac{x^3}{3} \right]_0^h}{\frac{b}{h} \left[\frac{x^2}{2} \right]_0^h} = \frac{\frac{bh^3}{3}}{\frac{bh^2}{2}}, \\ \bar{x} &= \frac{2}{3} h. \end{aligned} \tag{3}$$

We recognize the denominator of the last term of (3) as the area of the triangle, which shows that our increment of area was taken correctly and the proper limits were used.

The center of gravity of a triangular area falls on the line JK parallel to the base and at a distance from the base equal to one-third the altitude.

The triangle may be turned and the origin taken at E or D and another line at one-third the altitude from the new base may be found.

In Fig. 171, II, the line CL , drawn from the vertex C to the middle point of the base, passes through the center of gravity.

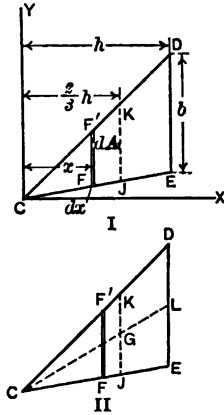

If we divide the triangle into narrow strips such as FF' by lines parallel to the base, this median line bisects each of these strips. The line CL passes through the center of gravity of each strip and each strip could be balanced on the line as a knife edge support. This is also true of median lines from D and E . *The center of gravity of a triangular area is at the intersection of the medians.* We know from geometry that the intersection of the medians of a triangle is two-thirds the length of any median from its vertex. The center of gravity of the triangle of Fig. 171, II, is at G on the median CL at a distance from L equal to one-third of CL .

If any plane area has a line of symmetry, the area could be balanced on this line; consequently the line of symmetry passes through the center of gravity of the area. If a solid is symmetrical with respect to a plane, this plane passes through the center of gravity of the solid. These facts enable us to locate the center of gravity of many areas and volumes without integrating.

PROBLEMS.

2. A triangle of base 6 inches and altitude 9 inches has its base on the upper edge of a 6-inch square. Knowing the location of the center of gravity of the triangle and square, find the distance of the center of gravity of the combined area from the base of the triangle. Prove the result by finding the distance from the base of the square used as the origin.

Ans. $\bar{y} = \frac{7}{3}$ inch when the origin is on ED of Fig. 172.

3. If the median line from C (Fig. 172) makes an angle of 60 degrees with the horizontal, find \bar{x} , using two origins, and compare the results.

4. A circular area 4 inches in diameter is tangent to a rectangle 4 inches

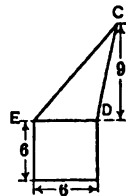

Fig. 172.

wide and 5 inches high at a point on the right side of the rectangle 2 inches above the lower right corner. Locate the center of gravity.

Ans. $\bar{x} = 3.54$ inches from the left side of rectangle;
 $\bar{y} = ?$

5. A rectangular board 12 inches wide and 16 inches high has a circular hole cut out. The center of the hole is 5 inches from the right edge and 5 inches from the bottom. Its diameter is 3 inches. Locate the center of gravity of the remainder.

This is easiest solved by subtracting from the moment of the entire board the moment of the area cut away.

6. Find the distance from the *Y* axis of the center of gravity of the plane area bounded by the *X* axis, the parabola $y^2 = 4x$, and the ordinate $x = 9$ (Fig 173, I).

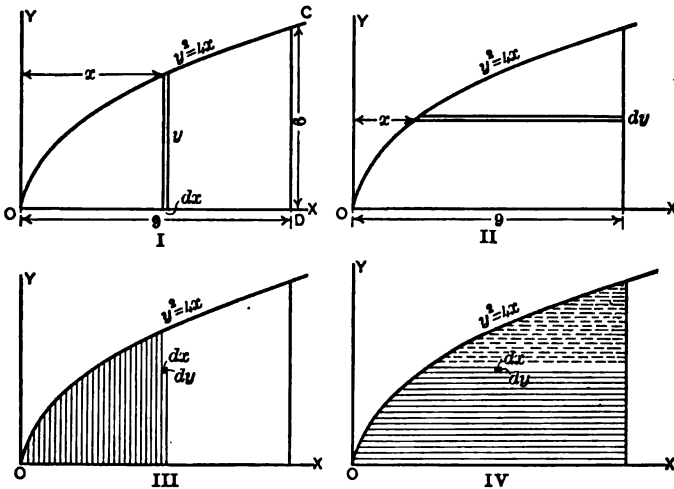

Fig. 173. — Center of Gravity of Area Bounded by a Parabola.

The element of area is $y dx$, and the moment arm is x of the curve

$$\bar{x} = \frac{\int xy dx}{\int y dx} \tag{1}$$

Since there are two variables in the integrals of (1), we must eliminate one of these by substituting its value in terms of the other from the equation of the curve. Solve first by eliminating y and integrating between the proper limits for x ; then solve by eliminating x and dx and integrating between the proper limits for y . Compare results. The result should be greater than one-half of 9 and should be less than 6. Why?

7. Solve Problem 6 for \bar{y} , using the element of area of Fig. 173, II. The result should be greater than 2 and less than 3. Why?

8. Solve Problem 7 for \bar{y} , using the element of area of Fig. 173, I.
9. Solve Problem 6 for \bar{x} , using the horizontal element of Fig. 173, II.
10. Solve Problem 6 for \bar{x} by double integration, using the element of area $dx dy$. Integrate first with respect to y and compare the result of this integration with the original integral of Problem 6.
11. Solve Problem 6 for \bar{x} by double integration, integrating first with respect to x . Compare result of this integration with the integral of Problem 9.
12. Solve for \bar{y} by double integration, integrating first with respect to y so as to build up vertical strips extending from the X axis to the curve (Fig. 173, III). Compare the result of this first integration with the integral of Problem 8.
13. Solve for \bar{y} by double integration, integrating first with respect to x (Fig. 173, IV).
14. Find \bar{x} of the area entirely bounded by the curve $y^2 = 4x$ and the straight line $3y = 2x$, by a single integration with element of area parallel to the Y axis. Ans. $\bar{x} = 3.6$.
15. Solve Problem 14 by subtracting from the moment and area of Problem 6 the moment and area of the triangle bounded by OD and DC and the straight line from O to C in Fig. 173, I.
16. Find \bar{x} of the area bounded by the Y axis, the line $y = 6$, the hyperbola $xy = 12$, the line $x = 12$, and the X axis, using a vertical strip as the increment of area.

$$\text{Ans. } \bar{x} = \frac{12 + \int xy dx}{12 + \int y dx} = \frac{12 + 12 \int dx}{12 + \int \frac{12}{x} dx} = \frac{12 + 12 [\bar{x}]_2^{12}}{12 + 12 [\log x]_2^{12}} = 3.94.$$

17. Solve Problem 16, using the element of area in the form of horizontal strips.
18. Find \bar{x} of a 60-degree sector of a circle of radius a with the X axis as one of the bounding lines (Fig. 174). Solve by polar coördinates, integrating first with respect to r . (The order of integration is immaterial in this case, as the limits of one variable are independent of the other variable. Where this is not the case, integrate first with respect to r .)

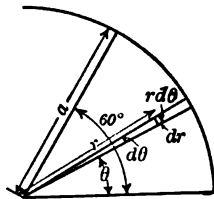

Fig. 174. — Center of Gravity of a Sector of a Circle.

$$\text{Ans. } x = \frac{\sqrt{3}a}{\pi} = 0.551a.$$

19. Using the value of x from Problem 18, find \bar{y} without integrating.

$$\text{Ans. } \bar{y} = \frac{a}{\pi}.$$

20. Solve Problem 18 for \bar{x} if the sector is so placed that the X axis bisects it. Compare with results of the preceding problems.
21. Find the center of gravity of segment of a circle of radius 10 bounded on one side by a straight line at a distance 5 from the center of the circle. Solve by rectangular coördinates, using strips parallel to the boundary line as increments of area. Ans. $\bar{x} = 7.05$.

Using only the half above the X axis and calling the radius a :

$$\begin{aligned} \bar{x} &= \frac{\int xy \, dx}{\int y \, dx} = \frac{\int (a^2 - x^2)^{\frac{1}{2}} x \, dx}{-a^2 \int \sin^2 \theta \, d\theta} \\ &= \frac{-\left[a^2 - x^2 \right]^{\frac{3}{2}}}{3} = \frac{a^3 \sqrt{3}}{8} \\ &= \frac{-a^2 \left[\frac{\theta}{2} - \frac{\sin 2\theta}{4} \right]_0^{\frac{\pi}{6}}}{a^2 \left[\frac{\pi}{6} - \frac{\sqrt{3}}{8} \right]} \end{aligned}$$

The independent variable is changed in the denominator and might also be changed in the numerator. Why is the upper limit in the denominator 0 and not $\frac{\pi}{3}$? Explain the geometric meaning of each term in the denominator.

22. Solve Problem 21 by double integration with polar coordinates (Fig. 175, II).

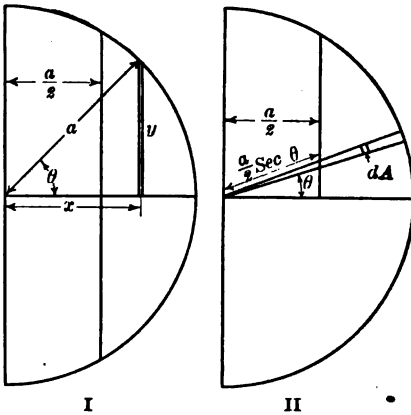

Fig. 175. — Center of Gravity of a Segment of a Circle.

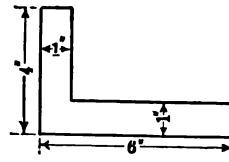

Fig. 176. — An Angle Section.

23. Find the center of gravity of a semicircular area of radius a .

Ans. $\bar{x} = \frac{4}{3} \frac{a}{\pi} = 0.4244 a$.

24. A regular hexagon is bisected by a line joining opposite angles. Find the distance of the center of gravity of the half hexagon from this line, without integrating.

25. Fig. 176 represents a 6-inch by 4-inch by 1-inch standard angle. Find the distance of the center of gravity from the back of each leg, and compare the results with the tables in Cambria.

26. Fig. 177 represents a standard 10-inch 15-pound channel section. Find the distance of the center of gravity of the section from the back of the web, and compare with Cambria under "Properties of Standard Channels."

27. Look up dimensions of a 12-inch 30-pound channel and calculate the area and the location of the center of gravity.

28. A section is made of two 10-inch 15-pound channels and one 12-inch by $\frac{1}{2}$ -inch plate. How far is the center of gravity of the section from the center of the channels (see Fig. 178)?

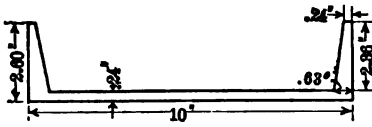

Fig. 177. — A Channel Section.

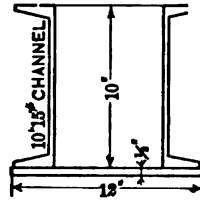

Fig. 178. — A Plate and Channel Column Section.

29. Find the center of gravity of an area inclosed by the X axis, a circle of 10 inches radius with center at the origin, the straight line $y = 2(x - 3)$, and the circle $x^2 + y^2 = 25$.

30. Find the center of gravity of the area between the circle with center at the origin and radius 6 and the rectangular hyperbola $xy = 12$.

31. A circular board 20 inches in diameter has a hole 5 inches in diameter cut out, the center of the hole being 4 inches from the center of the board. Find the center of gravity of the remainder.

32. Solve Problem 31 if the center of the hole is 8 inches from the center of the board.

Lewis P. McGilvary
Elect. Eng. 1913

CHAPTER XVII.
MOMENT OF INERTIA.

141. Definition.—The moment of inertia of a body with respect to an axis is the sum of the products obtained by multiplying the mass of each particle of the body by the square of its distance from the axis. If m is the mass of any particle, and r is its distance from the axis,

$$I = \Sigma mr^2.$$

For a continuous body, the definition expressed mathematically is

$$I = \int r^2 dM, \quad \text{Formula XXXI.}$$

where I is the moment of inertia and dM is any element of mass (finite or infinitesimal), all parts of which are at a distance r from the axis.

In Fig. 179, the Z axis is taken as the axis of inertia for the solid. The element BB' extending entirely through the body parallel to the Z axis is the element of mass of Formula XXXI.

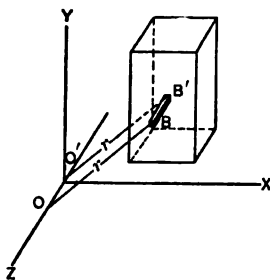

Fig. 179.

The element of mass of Formula XXXI. The element of mass might have the form of a hollow cylinder of radius r , and thickness dr . It could, of course, be of infinitesimal dimensions in three directions, in which case the volume would be represented by $dx dy dz$ in *rectangular coördinates*, by $r d\theta dr dz$ in *cylindrical or mixed coördinates*, and by $r^2 \sin \theta d\theta d\phi dr$ in *spherical coördinates* (with the Z axis as the axis of the sphere from which θ is measured). When taking moment of inertia with respect to the Z axis the values of r^2 of Formula XXXI in terms of the coördinates of the element are

- $x^2 + y^2$ for rectangular coördinates,
- r^2 for cylindrical coördinates,
- $r^2 \sin^2 \theta$ for spherical coördinates.

The element BB' of Fig. 179 may be regarded as an example of rectangular coordinates after integration with respect to Z . If its cross section were of the form of an element of area in polar coordinates it would be an example of the cylindrical element of volume after one integration. A second integration of this element of volume with respect to θ would give the hollow cylinder of thickness dr .

PROBLEMS.

1. Find the moment of inertia of a rectangular parallelepiped of width b , height d , and length l , with respect to an edge parallel to its length (Fig. 180) by double integration.

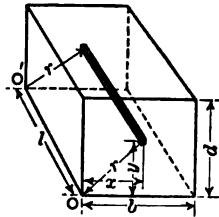

Fig. 180. — Moment of Inertia of Parallelepiped.

$$Ans. I = \frac{\rho b d l}{3} (b^2 + d^2) = \frac{M}{3} (b^2 + d^2),$$

where ρ is the mass per unit volume and M is the total mass.

2. Find I of a homogeneous solid cylinder of length l and radius a with respect to the axis of revolution (OO' , Fig. 181).

$$Ans. I = \frac{\pi \rho l a^4}{2} = \frac{M a^2}{2}.$$

This is a case of cylindrical coordinates. The element of volume for double integration has a length l and a cross section $r d\theta dr$. Integrating first with respect to r gives a wedge-shaped element between the planes whose traces on the front are the dotted lines OE and OF . The second integration builds up the cylinder of a series of such wedges.

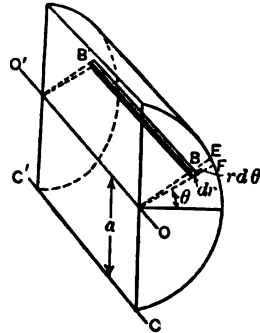

Fig. 181. — Moment of Inertia of Cylinder.

If θ be integrated first between the limits 0 and 2π , we get a hollow cylinder of radius r and thickness dr . The volume of this hollow cylinder is $2\pi r l dr$, and its moment of inertia with respect to the axis OO' is $2\pi \rho l r^3 dr$, which might have been obtained directly without integrating.

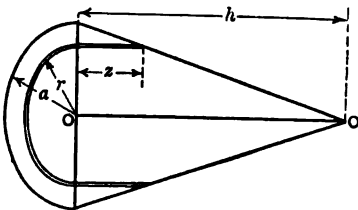

Fig. 182. — Moment of Inertia of Right Cone.

3. Find the moment of inertia of a right cone of height h and radius of base a with respect to the axis of revolution, by a single integration using a hollow cylinder as the element of volume.

$$Ans. I = 2\pi \rho r^2 z dr = 2\pi \rho h \int_0^a \left(r^3 - \frac{r^4}{a} \right) dr = \frac{\pi \rho a^4 h}{10} = \frac{3 M a^2}{10}.$$

4. Find the moment of inertia of a homogeneous solid sphere of radius a with respect to a diameter by double integration. Use as the element of

volume a ring of radius r and cross section $dr dz$ and integrate first with respect to z . *Ans.* $I = \frac{1}{3} Ma^2$.

5. Solve Problem 4, integrating first with respect to r . Show that this is the same as a single integration using a disk or short cylinder of length dz as the element of volume, and applying the results of Problem 2.

6. Solve Problem 3 by a single integration building the cone of flat disks parallel to the base, the moment of inertia of each disk being from Problem 2, $\frac{\pi r^4}{2} dz$, where r is measured from the axis to the surface.

142. Radius of Gyration. — The radius of gyration may be defined algebraically by the equations:

$$Mk^2 = I, \quad (1)$$

$$k^2 = \frac{I}{M}, \quad (2)$$

where k is the radius of gyration.*

The radius of gyration is the distance from the axis at which the entire mass could be concentrated and leave the moment of inertia unchanged. In the case of a homogeneous solid cylinder with respect to the axis of revolution,

$$I = \frac{Ma^2}{2};$$

$$k^2 = \frac{a^2}{2};$$

$$k = \frac{a}{\sqrt{2}} = 0.7071 a.$$

If the entire mass of a solid cylinder of radius a were condensed into a hollow cylinder of radius $0.707 a$ and negligible thickness, or into a single filament at a distance of $0.707 a$ from the axis, the moment of inertia in each case would be the same as that of the solid cylinder.

PROBLEMS.

1. Find the square of the radius of gyration of a homogeneous solid cylinder of 12 inches radius. *Ans.* $k^2 = 72$.

2. Find the radius of gyration of a parallelepiped of breadth 8 inches and depth 10 inches with respect to an axis parallel to the length along one edge (Problem 1, Article 141). *Ans.* $k = 7.39$ inches.

3. A solid cylinder of 6 inches radius weighing 40 pounds, is coaxial with a solid sphere of 8 inches radius weighing 60 pounds. Find the radius of gyration of the combination. *Ans.* $k = 4.75$ inches.

* In this chapter we shall represent radius of gyration by k to avoid confusion. In the chapter on columns it is represented by r which is customary in books on this subject.

4. Find the radius of gyration of a homogeneous hollow cylinder of outside radius a and inside radius b with respect to the axis of revolution.

$$\text{Ans. } k = \sqrt{\frac{a^2 + b^2}{2}}$$

5. By integration, find the moment of inertia of a homogeneous solid cylinder with respect to an element of the curved surface as an axis (CC' , Fig. 181).
 $\text{Ans. } I = \frac{1}{3} Ma^2$.

143. Transfer of Axis. — When it is necessary to find the moment of inertia with respect to some axis for which the equation of the solid is complicated the integration becomes laborious. Usually it is best to first find the moment of inertia with respect to an axis giving the simplest expression for the equation of the solid and then transfer to the new axis. If CC' is an axis passing through the center of gravity of a solid and OO' is a *parallel axis* at a distance d from it, we will prove that

$$I = I_0 + Md^2, \quad \text{Formula XXXII.}$$

where I is the moment of inertia with respect to OO' and I_0 is the moment of inertia with respect to CC' .

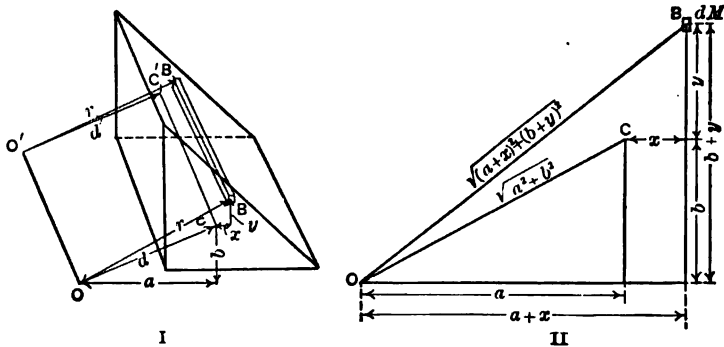

Fig. 183. — Transfer of Axis.

Let BB' (Fig. 183) be an element of mass parallel to the axes. Its coordinates with respect to the axis CC' are (x, y) . Let the coordinates of the center of gravity with respect to the axis OO' be (a, b) so that $d = \sqrt{a^2 + b^2}$. With respect to OO' the value of r^2 in the expression

$$I = \int r^2 dM$$

is

$$r^2 = (a + x)^2 + (b + y)^2.$$

With respect to OO' the expression for the moment of inertia is

$$I = \int (a^2 + 2ax + x^2 + b^2 + 2by + y^2) dM. \quad (1)$$

$$I = \int (x^2 + y^2) dM + (a^2 + b^2) \int dM + 2a \int x dM + 2b \int y dM. \quad (2)$$

We recognize the first term of the second member of (2) as the moment of inertia with respect to CC' . The second term is $(a^2 + b^2) M$, which is $M d^2$.

The third term, $2a \int x dM$, is zero; $x dM$ being the moment of dM with respect to a vertical plane through CC' , and the sum of these moments is zero when the center of gravity falls in this vertical plane.

Also
$$\bar{y} = \int \frac{y dM}{M}.$$

When y is measured from the center of gravity $\bar{y} = 0$ and $\int \frac{y dM}{M} = 0$, consequently the last term of (2) is zero and equation (2) becomes Formula XXXII.

PROBLEMS.

1. Solve Problem 5 of Article 142 by means of Formula XXXII and the answer of Problem 2 of Article 141.

2. Find the moment of inertia of a homogeneous solid sphere of radius a with respect to a tangent, and compute the square of the radius of gyration.
Ans. $k^2 = 1.4 a^2$.

3. Find the radius of gyration of a homogeneous solid cylinder of 6 inches radius with respect to an axis 10 inches from the axis of revolution and parallel to it.
Ans. $k = 10.86$ inches.

4. Find the radius of gyration of a parallelepiped of breadth 8 inches, and depth 10 inches with respect to an axis parallel to its length through the center of gravity, by means of the result of Problem 2, Article 142, and Formula XXXII.

144. Moment of Inertia of a Thin Plate.

— In Fig. 184, if we take the moment of inertia with respect to the vertical axis FF' , we get from Problem 1 of Article 141

$$I = \frac{b dl}{3} (b^2 + l^2) = \frac{M}{3} (b^2 + l^2).$$

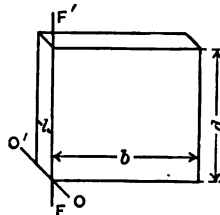

Fig. 184.

If l is small relatively to b , l^2 may be neglected and

$$I = \frac{Mb^2}{3}.$$

In a similar manner in respect to an axis through the center if b is small compared with l ,

$$I = \frac{Ml^2}{12}.$$

PROBLEMS.

1. A rectangular board 40 inches long and 1 inch thick weighs 6 pounds. Find its moment of inertia with respect to an axis parallel to its breadth through its center of gravity. Ans. $I = 800.5$.
2. In Problem 1 what is the moment of inertia if the thickness is neglected?
3. A rectangular rod 60 inches long is 1 inch square. Find its radius of gyration with respect to an axis through the middle of one end perpendicular to its length. What difference does it make if the thickness is neglected?

Fig. 185 represents a plate of uniform thickness t and of any form whatever. The axis OO' is parallel to the plane surfaces.

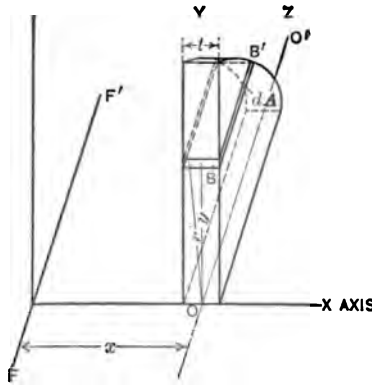

Fig. 185.

The element of volume BB' has its long dimension parallel to OO' . If the thickness of the plate is so small relatively that the radius r drawn from any point in it to the axis OO' is not appreciably greater than the smallest radius y , then the entire element may be used as the

mass element in $\int r^2 dM$, which

becomes $\int y^2 dM$ for this figure.

If dA is the cross section of the element parallel to the YZ plane its volume is $t dA$. The moment of inertia of a thin plate with respect to an axis in one of its surfaces or an axis between these surfaces is

$$I = \rho t \int y^2 dA, \quad (1)$$

where dA is an element of the surface.

145. **Moment of Inertia of a Plane Area.*** — If dA is an element of an area at a distance r from some axis, $\int r^2 dA$ is called the *moment of inertia* of the area with respect to the axis. If the axis lies in the plane of the area, the moment of inertia of the area is the same as that of a thin plate of such thickness and density that its mass is unity per unit area. In equation (1) of the preceding article, if the product ρt is unity, the expression gives the moment of inertia of a plane area with respect to a horizontal axis.

The moment of inertia of an area with respect to an axis in its plane is a factor in all problems concerning the strength and deflection of beams and columns.

The moment of inertia of a surface with respect to an axis normal to its plane is called the *polar moment* of inertia of the surface. The polar moment of inertia of a surface is equivalent to the moment of inertia of a solid plate of the same dimensions as the surface and of such thickness and density that its mass is unity per unit area.

In Problem 2 of Article 141 we found the moment of inertia of a solid cylinder to be

$$I = \frac{\pi \rho l a^4}{2}.$$

If ρl is unity this gives for the polar moment of inertia of a circle with respect to an axis through its center

$$J = \frac{\pi a^4}{2} = \frac{A a^2}{2},$$

where J represents the polar moment of inertia.

In a similar way we find the polar moment of inertia of a rectangle of sides b and d , with respect to an axis through one corner, to be

$$\frac{bd}{3}(b^2 + d^2) = \frac{A}{3}(b^2 + d^2).$$

Formula XXXII holds for moment of inertia of areas.

* In reality this is not a true moment of inertia in the physical sense of the term, as an area has no mass, but as the mathematical expression is similar in form to a true moment of inertia, it is convenient and customary to call it the moment of inertia of the area.

PROBLEMS.

1. By integration find the moment of inertia of a rectangle of breadth b and depth d with respect to the side b . *Ans.* $I = \frac{bd^3}{3}$.

2. By transfer of axis find the moment of inertia of a rectangle of sides b and d with respect to an axis in the plane of the area parallel to b and passing through the center of the rectangle. *Ans.* $I = \frac{bd^3}{12}$.

3. By integration find the moment of inertia of a circular area of radius a with respect to a diameter. *Ans.* $I = \frac{\pi a^4}{4}$.

The results of Problems 1, 2, and 3 should be memorized on account of their importance in the theory of beams and columns.

4. What is the radius of gyration of a circular area with respect to a diameter?

5. Find the polar moment of inertia of a square with respect to one corner. How does it compare with the moment of inertia with respect to a side of the square? *Ans.* $J = 2I$.

6. Compare the polar moment of a circle with respect to an axis through the center with the moment of inertia with respect to a diameter.

7. Find the moment of inertia of a triangle of base b and altitude h with respect to a line through the vertex parallel to the base. From this result by transfer of axes find the moment of inertia of the triangle with respect to the base. *Ans.* $I = \frac{bh^3}{12}$ with respect to the base.

8. Find the moment of inertia of a 6-inch by 4-inch by 1-inch angle section (Fig. 186) with respect to an axis (1-1) through the center of gravity parallel to the longer leg. Divide the section into two rectangles. Find the moment of inertia of each with respect to a line through its center of gravity, then transfer to axis (1-1) and add. As a check find the moment of inertia of the entire figure with respect to some axis which is a common base of both rectangles (as BC , or a horizontal line through D), then transfer to the center of gravity. Compare result with table in Cambria.

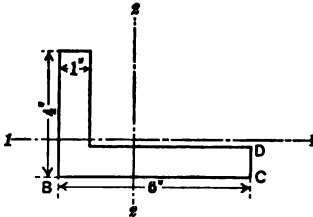

Fig. 186. — Moment of Inertia of Angle Section.

9. Find the moment of inertia of the above angle section with respect to an axis through the center of gravity parallel to the shorter leg.

10. A "plate-and-angle column" (see Cambria) is made of four 4-inch by 3-inch by $\frac{1}{2}$ -inch angles and one 12-inch by $\frac{1}{2}$ -inch plate. The angles are riveted to the plate, the back of the longer legs being one-eighth inch above and below the edges of the plate. Taking the moments of inertia and location of centers of gravity from Cambria tables of angle sections, find the moment of inertia of the entire section with respect to the two lines of symmetry.

11. Look up in Cambria the "Diagram for Minimum Standard Channels" and derive the formula for the moment of inertia there given.

12. From the dimensions given in Cambria find the moment of inertia of a 15-inch 33-pound standard channel with respect to an axis through the center of gravity of the section perpendicular to the web.

13. A "plate-and-channel column" is made of two 15-inch 40-pound channels placed $12\frac{1}{2}$ inches back to back (with toes out), and two 20-inch by $\frac{3}{4}$ -inch plates. Taking the moments of inertia of the channels from the table of the properties of channel sections, find the moment of inertia of the section with respect to an axis parallel to the channel webs and midway between them and also with respect to an axis parallel to the plates through the centers of the channels.

14. Find the moment of inertia of an 8-inch by 3-inch by $\frac{1}{2}$ -inch Z-bar section with respect to axes through the center of gravity parallel and perpendicular to the web.

15. Find the two principal moments of inertia of a 20-inch 65-pound standard I-beam section. Derive the formula used.

146. Change of Direction of Axis. — Formula XXXII enables us to transfer moment of inertia from one axis to a parallel axis. It is frequently necessary to transform to an axis at an angle with the original axis.

Fig. 187 represents an area in the XY plane. The moment of inertia of this area with respect to the X axis OX we will call I_x , and the moment of inertia with respect to the Y axis we will call I_y :

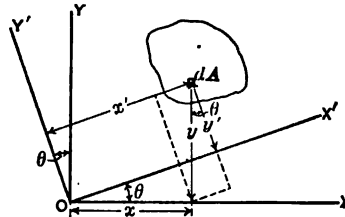

Fig. 187. — Change of Direction of Axis.

$$I_x = \int y^2 dA;$$

$$I_y = \int x^2 dA.$$

Let OX' , OY' be new axes making an angle θ with the X and Y axes respectively. The coördinates of the element of area dA with respect to these new axes are (x', y') .

The moment of inertia of the area with respect to OX' is

$$I = \int y'^2 dA. \tag{1}$$

From the geometry of the figure

$$y' = y \cos \theta - x \sin \theta. \tag{2}$$

$$I = \int (y^2 \cos^2 \theta - 2xy \cos \theta \sin \theta + x^2 \sin^2 \theta) dA. \tag{3}$$

$$I = I_x \cos^2 \theta + I_y \sin^2 \theta - \sin 2\theta \int xy \, dA. \quad (4)$$

$$I = \frac{I_x + I_y}{2} + \frac{I_x - I_y}{2} \cos 2\theta - \sin 2\theta \int xy \, dA. \quad (5)$$

PROBLEMS.

1. Find the moment of inertia of a rectangle 4 inches wide and 3 inches high with respect to an axis in its plane which passes through the lower left corner and makes an angle of 20 degrees with the horizontal.

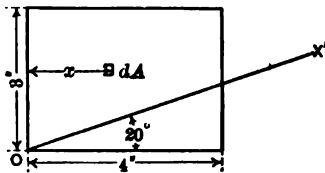

Fig. 188. — Moment of Inertia with Respect to OX' .

$$I_x = 36 \text{ inches}^4,$$

$$I_y = 64 \text{ inches}^4.$$

$$\int xy \, dA = \int_0^4 \int_0^3 xy \, dx \, dy = 36 \text{ inches}^4.$$

$$I = 50 - 14 \cos 40^\circ - 36 \sin 40^\circ = 16.14 \text{ inches}^4.$$

2. Solve Problem 1 if the axis passes through the lower left corner and makes a negative angle of 20 degrees with the horizontal.

Ans. $I = 62.42 \text{ inches}^4$.

3. Find the moment of inertia of a 3-inch by 4-inch rectangle with respect to a diagonal by means of equation (5) and check by the moment of inertia of two triangles with respect to the diagonal as a common base (Problem 7, Article 145).

147. **Product of Inertia.** — The expression $\int xy \, dA$ is called the *product of inertia* of the area. It is represented algebraically by the letter H .

If an area is symmetrical with respect to either one of a pair of rectangular axes, its product of inertia with respect to that pair of axes is zero. Fig. 189 represents an area symmetrical with respect to the Y axis. If we integrate first with respect to x ,

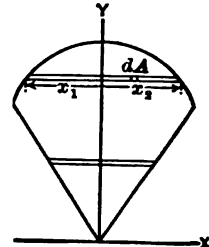

Fig. 189.

$$H = \frac{1}{2} \int [x^2]_{x_1}^{x_2} y \, dy = \frac{1}{2} \int [x_2^2 - x_1^2] y \, dy.$$

If the area is symmetrical with respect to the Y axis, the lower limit x_1 is numerically equal and opposite in sign to the upper limit x_2 , and the squares are the same in magnitude and sign; consequently the term in the brackets vanishes and

$$H = 0.$$

When the product of inertia is known with respect to a pair of rectangular axes through the center of gravity of an area, it may be calculated for a second pair of parallel axes in the plane of the area by a formula similar to XXXII for the transfer of moments of inertia.

Let OX, OY , Fig. 190, be the original pair of axes through the center of gravity, and let (x, y) be the coördinates of an element dA with reference to these axes. Let $O'X', O'Y'$ be a new pair of parallel axes. Let (a, b) be the coördinates of the center of gravity of the area with respect to the new axes.

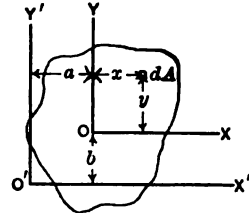

Fig. 190. — Transfer of Axes for Product of Inertia.

If H is the product of inertia with respect to the new axes,

$$H = \int (a + x)(b + y) dA. \tag{1}$$

$$H = ab \int dA + b \int x dA + a \int y dA + \int xy dA. \tag{2}$$

$$H = abA + 0 + 0 + H_0, \tag{3}$$

where H_0 is the product of inertia with respect to the axes through the center of gravity. Equation (3) is easily remembered from Formula XXXII, replacing the square by the product.

If the center of gravity of an area falls in the first or third quadrant with respect to the axes for which its product of inertia is taken, H is positive; if the center of gravity falls in the second or fourth quadrant, H is negative.

PROBLEMS.

1. Find the product of inertia of a rectangle 6 inches wide and 4 inches high with respect to the lower and left edges as axes. Ans. $H = 144$ inches⁴.
2. Find the product of inertia of a rectangle 5 inches wide and 4 inches high with respect to the lower edge and a vertical line 1 inch to the left of the right edge. Ans. $H = -60$.
3. Find the product of inertia of the 6-inch by 4-inch by 1-inch angle section of Fig. 186 with respect to the axes 1-1 and 2-2.

148. Transformation of Direction of Axes for Product of Inertia. — To get the product of inertia for the axes OX', OY' of Fig. 187, we have:

$$H' = \int x'y' dA, \tag{1}$$

$$H' = \int (x \cos \theta + y \sin \theta) (y \cos \theta - x \sin \theta) dA, \quad (2)$$

$$H' = (\cos^2 \theta - \sin^2 \theta) \int xy dA + \cos \theta \sin \theta \int (y^2 - x^2) dA, \quad (3)$$

$$H' = H \cos 2\theta + \frac{I_x - I_y}{2} \sin 2\theta. \quad (4)$$

H' becomes zero when the right member of (4) = 0, when

$$\tan 2\theta = \frac{2H}{I_y - I_x}. \quad (5)$$

PROBLEMS.

1. In the 4-inch by 3-inch rectangle of Fig. 188 what will be the angle between OX' and the 4-inch edge if the product of inertia with respect to OX' and the axis through O normal to it is zero? *Ans.* $\theta = 34^\circ 22'$.

2. Find the direction of the pair of axes through the center of gravity of the 6-inch by 4-inch by 1-inch angle section of Fig. 186 for which the product of inertia is zero.

149. Direction of Axis for Maximum Moment of Inertia. — Equation (5) of Article 146 is written:

$$I = \frac{I_x + I_y}{2} + \frac{I_x - I_y}{2} \cos 2\theta - H \sin 2\theta. \quad (1)$$

Differentiating with respect to θ ,

$$\frac{dI}{d\theta} = (I_y - I_x) \sin 2\theta - 2H \cos 2\theta, \quad (2)$$

from which the condition of maximum or minimum is

$$\tan 2\theta = \frac{2H}{I_y - I_x}. \quad (3)$$

Comparing (3) with (5) of Article 148, we find that the condition of maximum or minimum moment of inertia is the condition which gives zero product of inertia. There are two solutions for (3), which give values of 2θ differing by 180° and values of θ differing by 90° . One of these positions is that of maximum moment of inertia and the other is that of minimum moment of inertia.

PROBLEMS.

1. In the rectangle of Problem 1 of Article 148 find the maximum and minimum moment of inertia for axes through one corner.

2. In Problem 2 of Article 148 find the maximum and minimum moment of inertia and compare the minimum with the table in Cambria.

3. What is the direction of the axis for which the moment of inertia is a minimum for an angle section with equal legs? Why?

4. In the case of an 8-inch by 8-inch by 1-inch angle section calculate the distance of the center of gravity from the back of the leg. Find the moment of inertia with respect to an axis through the center of gravity parallel to the leg. Find the minimum and maximum moment of inertia for axes through the center of gravity. When the work is complete compare with Cambria.

5. Solve the 8-inch by 3-inch by $\frac{1}{2}$ -inch Z-bar section completely for the least radius of gyration.

The maximum and minimum moments of inertia of an area for axes through a given point are called the *principal moments of inertia*, and the corresponding axes are the principal axes.

If the minimum moment of inertia is known, it is generally easy to find the maximum by means of a simple relation

$$I_{\max} + I_{\min} = I_x + I_y = J.$$

The sum of the moments of inertia of a plane area for any pair of rectangular axes in the plane is equal to the polar moment of inertia for their point of intersection.

Let one of these axes be used as the X axis.

$$I_x = \int y^2 dA.$$

If the other rectangular axis is used as the Y axis,

$$I_y = \int x^2 dA.$$

For the polar moment of inertia $r^2 = x^2 + y^2$,

$$J = \int (x^2 + y^2) dA = \int x^2 dA + \int y^2 dA.$$

PROBLEMS.

6. Using all the data you can find in Cambria, calculate the maximum moment of inertia of a 5-inch by 3-inch by $\frac{1}{2}$ -inch angle section.

7. Find the least and greatest moment of inertia and radius of gyration of a semicircular area of radius a with respect to axes in its plane passing the end of the diameter which bounds it.

150. The Moment of Inertia of a Prism or Pyramid. — The moment of inertia of any solid may be found by triple integration with an element which is infinitesimal in each direction, or by double integration with an element which is infinitesimal in two

directions and extends entirely through the mass in the direction of the axis.

It is often easier to use a thin plate or disk which is infinitesimal in one direction only as the element of volume, provided the moment of inertia of this element is known with respect to an axis through its center of gravity parallel to the axis of inertia.

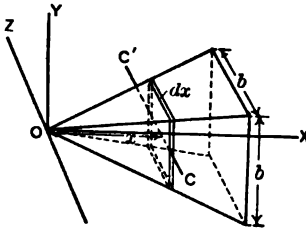

Fig. 191.

PROBLEMS.

1. Find the moment of inertia of a right pyramid of height h , with a square base of side b , with respect to an axis through the vertex perpendicular to the base.

The element of volume is the square plate of thickness dx . Its volume is $A dx$, where A is the area of the section. From similar solids (Fig. 191),

$$A = \frac{b^2 x^2}{h^2}.$$

As each side is $\frac{bx}{h}$, its polar moment of inertia with respect to the X axis is $\frac{\rho b^4 x^4}{6 h^4} dx$. The total moment of inertia is the sum of that of the several plates.

$$I = \frac{\rho b^4 x^5}{30 h^4} = \frac{\rho b^4 h}{30} = \frac{M b^2}{10}.$$

2. Find the moment of inertia of a right pyramid, the base of which is a hexagon of side a , with respect to an axis through the vertex perpendicular to the base.

If in Fig. 191 we wished to find the moment of inertia with respect to the Z axis OZ , we could find the moment of inertia of the plate with respect to the parallel axis CC' and then transfer to the Z axis. The moment of inertia of the plate is the same as that of the area of the plate with respect to a line in its plane multiplied by the thickness dx and the density. The moment of inertia of the plate about CC' is

$$I_0 = \frac{\rho b^4 x^4}{12 h^4} dx;$$

$$M d^2 = \frac{\rho b^2 x^4}{h^2} dx,$$

where I_0 and $M d^2$ have the meaning of Formula XXXII.

$$I = \rho \left(\frac{b^4 x^5}{60 h^4} + \frac{b^2 x^5}{5 h^2} \right) = \frac{\rho b^2 h}{5} \left(\frac{b^2}{12} + h^2 \right).$$

PROBLEMS.

3. Find the square of the radius of gyration of a right pyramid 24 inches high with base 12 inches square with reference to an axis through the vertex parallel to the base. *Ans.* $k^2 = 352.8$ inches².

4. Find the moment of inertia of a right cylinder of radius a and length l with respect to an axis perpendicular to the axis of the cylinder through the center of one end. *Ans.* $k^2 = \frac{l^2}{3} + \frac{a^2}{4}$.

Observing the answer of Problem 4, we see that the square of the radius of gyration is made of two terms, the first of which is k^2 for a long thin rod with respect to an axis through one end perpendicular to its length, and the other is k^2 for a circular area with respect to a diameter. The moment of inertia of any solid with a constant cross section and ending with parallel planes normal to its length (any right prism or cylinder) may be calculated in the same way. Expressed algebraically,

$$k^2 = k_l^2 + k_A^2, \tag{1}$$

where k_l is the radius of gyration of the prism regarded as a thin rod and k_A is the radius of gyration of a cross section. Fig. 192

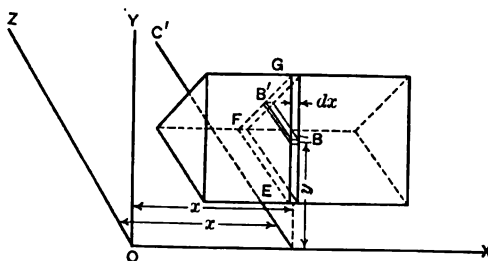

Fig. 192.

represents a triangular prism with its axis parallel to the X axis. It is desired to find its moment of inertia with respect to the Z axis.

Using the element BB' (Fig. 192) of cross section $dx dy$ extending entirely through the body in the direction of the Z axis:

$$I = \rho \int \int (x^2 + y^2) dx dA, \tag{2}$$

where dA is an area of length BB' and height dy .

$$I = \rho \int \int x^2 dx dA + \rho \int \int y^2 dx dA. \quad (3)$$

When we integrate with respect to dA , x remains unchanged, as we simply pile up elements of the form of BB' from the bottom of the top of the section EFG between vertical planes at a distance dx apart:

$$I = \rho \int x^2 A dx + \rho \int I_A dx, \quad (4)$$

where A is the area of the section, and I_A is the moment of inertia of the plane area with respect to the axis CC' in the XZ plane parallel to the Z axis.

Equation (4) applies to a solid of any form whatever, and is not limited to a prism as shown in the figure. If the line OX passed through the center of gravity of all the sections, we would have an example of Formula XXXII as in Problems 3 and 4.

If the solid is a prism or cylinder with the axis parallel to the X axis, A is constant and I_A is constant; then

$$I = \rho A \int x^2 dx + \rho I_A \int dx. \quad (5)$$

The first term of the last member of (5) is the moment of inertia of a thin rod with respect to an axis perpendicular to its length. The second member is equal to $\rho A k_A^2 = M k_A^2$, which proves equation (1).

PROBLEMS.

5. Find the moment of inertia of a right cylinder 18 inches long and 12 inches in diameter with respect to an axis in the plane of one end and tangent to the cylinder. *Ans.* $I = 153 M$.

6. Find the moment of inertia of a prism 6 inches square and 24 inches long with respect to an axis in the plane of one end perpendicular to the end of a diagonal. *Ans.* $I = M(192 + 21)$.

MISCELLANEOUS PROBLEMS.

1. A homogeneous solid sphere 6 inches in diameter is placed at the end of a homogeneous solid cylinder 2 inches in diameter and 40 inches long, the center of the sphere being in the line of the axis of the cylinder. If the cylinder and sphere have the same density, locate the center of gravity of the combination. *Ans.* 9.105 inches from the point of contact.

2. In Problem 1 what is the radius of gyration with respect to a diameter of the cylinder in the end opposite the sphere? *Ans.* 34 inches nearly.

3. The section of a right prism is an equilateral triangle 4 inches on each side. Its length is 30 inches. What is its radius of gyration with respect to the line of intersection of a side and an end? *Ans. $k = 17.38$ inches.*
4. A block 20 inches long, 16 inches wide, and 12 inches thick has a round hole 10 inches in diameter and 6 inches deep in the middle of the left end. Find the center of gravity of the remainder.
5. In Problem 4 find the moment of inertia and the radius of gyration with respect to an axis through the middle of the right end parallel to the 12-inch faces.
6. Show that the radius of gyration of a square area with respect to any axis in its plane through the center of gravity is the same.

Lewis P. McGilvary
Elect. Eng. 1916

CHAPTER XVIII.

COMPUTATION WITHOUT INTEGRALS.

151. Areas Which Cannot be Integrated. — In order to integrate a plane surface for area, center of gravity, or moment of inertia, we must first know the equations of the curves which form its boundary lines. It sometimes happens that sections are used which are not conveniently expressed in simple equations. More frequently the engineer is called upon to compute the constants of some section designed in accordance with some more or less simple expressions which cannot easily be determined from measurements of the finished product.

When a section is bounded by several curves having different equations, it requires considerable labor to make the several integrations and put in the appropriate limits.

For these reasons it is occasionally necessary, and often convenient, to determine center of gravity and moment of inertia by approximate computations or physical experiments.

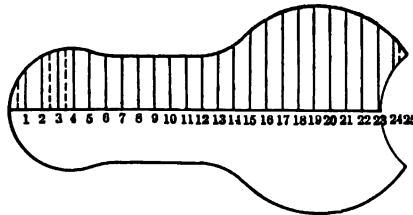

Fig. 193. — Finite Increments of Area.

152. Approximate Computation. — For approximate computations it is usually best to make an accurate drawing of the section, preferably on squared paper. If the section is symmetrical with respect to any line, it is necessary to draw and calculate only one-half, as in Fig. 193.

Each ordinate in Fig. 193 may be taken as approximately the mean altitude of a strip one unit wide extending one-half unit

on each side. The ordinate 3 is the mean altitude of the strip, extending from 2.5 to 3.5 between the dotted lines. To get the area, simply measure each ordinate (from 1 to 24 inclusive in Fig. 193), and multiply the sum of these by the common interval. This gives the entire area from 0.5 to 24.5. The small triangles outside these limits may be computed separately. To get the moment of the area in order to calculate the center of gravity, multiply each ordinate by its abscissa and add.

For the moment of inertia with respect to the origin, multiply each ordinate by the square of its abscissa and add the results. To this sum add one-twelfth of the product obtained by multiplying the sum of the ordinates by the square of the horizontal interval. Also add in the moment of inertia of the limiting triangles.

To get the moment of inertia with respect to a line through the center of gravity, transfer by Formula XXXII.

At 0.5 the ordinate is 2, making the *area* of the triangle 0.5 square unit. The moment arm of this triangle is $\frac{1}{3}$, so that the moment and moment of inertia are nearly negligible. At 24.5 the ordinate is 1; the area is 0.25; the moment arm is 24.67.

The quantity 8.9 which is added to the moment of inertia is the sum of the moments of inertia of the strips about their centers of gravity.

PROBLEMS.

1. In the figure of Table XI, how far is the center of gravity from the origin? *Ans.* 13.66 units.
2. If each unit represents 1 inch, what is the moment of inertia of the half of the figure above the *X* axis with respect to a vertical line through the center of gravity? *Ans.* 5023.8 inches⁴.
3. If each unit represents $\frac{1}{2}$ inch, what is this moment of inertia? *Ans.* 314 inches⁴.
4. Using the ordinates of Table XI, with the addition that 24 extends from 2.5 to 4.4, and 24.5 extends from 3.0 to 4.0, find the center of gravity of the upper half of Fig. 193 from the *X* axis, using the vertical strips.
5. Find the moment of inertia of the upper half of the figure with respect to the *X* axis.
6. Plot the curve $y^2 = 4x$. Find the center of gravity of the area between the positive part of this curve, the *X* axis, and the ordinate $x = 4$ by the approximate method. Use paper ruled 10 lines to the inch and take the first, third, fifth ordinate, etc. Compare result with that obtained by integration.
7. Solve Problem 6 for moment of inertia with respect to axes through the center of gravity parallel to the *X* and *Y* axes.

The calculation of the area of Fig. 193 is shown by Table XI, taking each division as unity.

TABLE XI.
COMPUTATION OF AREA, CENTER OF GRAVITY, AND MOMENT OF INERTIA
OF FIGURE 193.

x	y	xy	x^2y
1	2.8	2.8	2.8
2	3.6	7.2	14.4
3	3.9	11.7	35.1
4	4.0	16.0	64.0
5	3.9	19.5	97.5
6	3.6	21.6	127.6
7	3.4	23.8	166.6
8	3.4	27.2	217.6
9	3.4	30.6	275.4
10	3.4	34.0	340.0
11	3.4	37.4	411.4
12	3.4	40.8	489.6
13	3.5	45.5	591.5
14	4.0	56.0	784.0
15	5.0	75.0	1,125.0
16	5.5	88.0	1,408.0
17	6.1	103.7	1,762.9
18	6.45	116.1	2,089.8
19	6.55	124.4	2,364.5
20	6.5	130.0	2,600.0
21	6.25	131.3	2,756.3
22	6.0	132.0	2,904.0
23	5.3	121.9	2,803.7
24	1.9	45.6	1,094.4
	<hr/>	<hr/>	<hr/>
	105.25	1,442.1	24,526.1
24.5	.25*	6.1	152.1
.5	.5
	<hr/>	<hr/>	<hr/>
	106.0	1,448.2	24,678.2
			8.9
			<hr/>
			24,687.1

* The last two figures are areas of triangles.

153. **Center of Gravity by Experiment.** — The center of gravity of a section may easily be determined by cutting it out of uniform cardboard or sheet metal, and balancing on a knife edge. A better method of finding the center of gravity is that of balancing it on the beam of a platform scale or similar device.

Fig. 194, I, represents a body on a beam balanced by the poise in the position shown. If the body is turned end for end on the beam with the edge O not changed, so as to come into the position shown by the dotted lines, the center of gravity is moved a distance GG' , which is twice its distance from the O . To get a balance, the poise P must be moved to the dotted position P' . If the mass of the body is known in terms of the poise, the dis-

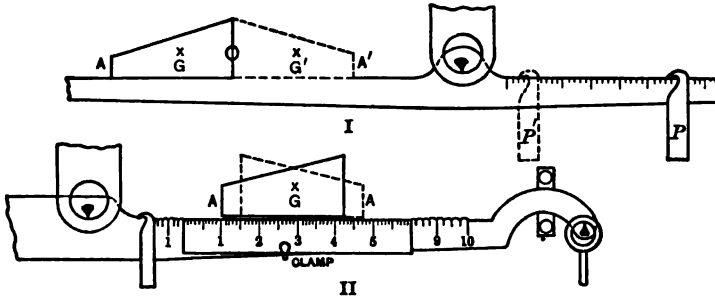

Fig. 194. — Center of Gravity by Balancing.

tance GG' may easily be calculated. Instead of rotating about the end O , any vertical line may be used as the line of reference, whose position on the beam is not changed.

PROBLEM.

1. A body weighing 4.50 pounds is balanced on a scale beam. When turned about a vertical line through the end nearest the knife edge, the apparent change in weight is 0.576 pound. The distance from the central knife edge to the end knife edges is 10 inches. How far is the center of gravity from the line about which it turned? *Ans.* 0.64 inch.

The method just given requires that we know the weight of the poise and the value in inches of a division on the scale, or that we know the distance from the central knife edge to the knife edge, upon which 1 pound weighs 1 pound. Another method is that shown by Fig. 194, II. The body is placed on the beam as before and moved till equilibrium is secured with some convenient weight on the opposite end. It is then turned end for end and moved along the scale beam until the same balance is secured, with all other weights unchanged. The center of gravity is now in the same position which it occupied before turning. If the position of any point such as A is noted before turning and again after turning, the difference of these

two positions is twice the horizontal distance of A from the center of gravity. This may be done with great accuracy on the beam of a platform scale by clamping to the beam a small steel scale for determination of the displacement of the points as shown in the figure.

PROBLEM.

2. A body is balanced on a scale beam. When turned around and again balanced, it is found that the point originally at the left end is displaced 3.32 inches. How far is the center of gravity from this end? *Ans.* 1.66 inches.

154. Moment of Inertia by Experiment. — A common method of finding the moment of inertia of an irregular body is that of determining its effect upon the time of vibration of a torsion pendulum. The time of vibration of a torsion pendulum varies as the square root of the moment of inertia of its mass with respect to the vertical line which is the axis of the supporting wire. This relation may be expressed briefly:

$$T^2 = KI,$$

where T may be the time of a complete period or of a single vibration (with K varying accordingly), and K is a constant

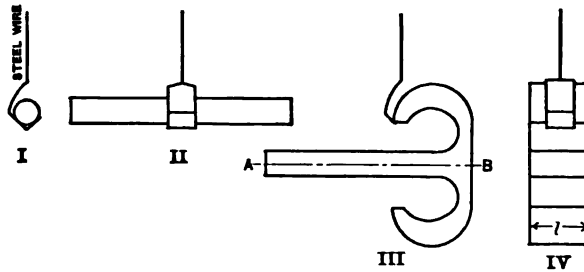

Fig. 195. — Moment of Inertia by Torsional Vibration.

which depends upon the length, diameter, and modulus of shearing elasticity of the supporting wire. The factors which make up K need not be determined separately, as the entire term may be obtained by substitution from the time of vibration of a mass of known moment of inertia.

Fig. 195, I and II, shows a uniform solid circular steel or brass rod in a horizontal position on a light support suspended by a single steel wire. Fig. 195, III and IV, shows a second body on the same support. It is desired to find the moment of inertia

of this second body with respect to an axis through its center of gravity perpendicular to the line AB . If the body can be so supported that AB is horizontal, it will rotate about the desired axis; for the center of gravity of the combined body and support must fall directly under the axis of the wire, and if the support is small relatively this combined center of gravity will practically coincide with that of the body, even if the support does not hang in exactly the position which it occupies when it is not loaded.

When the moment of inertia of the support is small, as in Fig. 195, the unknown moment of inertia is calculated from

$$\frac{I_A}{I_C} = \frac{T_A^2}{T_C^2},$$

where the subscript A refers to the body and the subscript C to the cylinder.

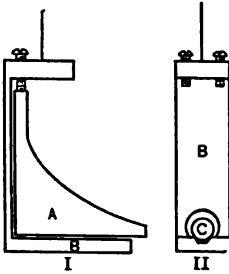

Fig. 196. — Support for Torsional Vibration.

Generally it is not practicable to use a very light support and get the body in the desired position. Fig. 196 shows a relatively large support carrying the unknown body in the side elevation of Fig. 196, I, and the known cylinder in the other. In this case we get the time of vibration with the support alone; and then with the support and each load separately.

$$\begin{aligned} T_B^2 &= KI_B, \\ T_C^2 &= K(I_C + I_B), \\ T_A^2 &= K(I_A + I_B), \end{aligned}$$

where T_C is the time with support and cylinder; T_B , with the support alone, etc.

$$I_A = \frac{(T_A^2 - T_B^2) I_C}{T_C^2 - T_B^2}.$$

PROBLEMS.

1. The time of vibration of a given torsion pendulum with the support alone is 0.46 second; with the support loaded with a cylinder 10 inches long and $\frac{1}{2}$ inch in diameter it is 0.87 second; with an unknown body in place of the cylinder it is 0.94 second. The cylinder weighs 0.556 pound and the body 1.25 pounds. Find the moment of inertia and radius of gyration of the body.

Ans. $k = 2.14$ inches.

2. Under what conditions may the unknown moment of inertia be accurately determined without getting the time of vibration of the support?
3. If any clamp screws are used in the support, they should be vertical. Why?

155. The Moment of Inertia of a Plane Section. — The method of the preceding article affords a method of obtaining the moment of inertia of any plane section when the material can be cut up into pieces. Suppose we have a beam of any irregular section. Cut out a piece of some convenient length and finish the ends to parallel planes perpendicular to the length of the beam. A convenient length for the finished piece is 1 inch. Determine the area of cross section by calculation from the weight and the specific gravity. Get the center of gravity by the method of Article 153. Suspend, and compute the moment of inertia. Divide by the weight for k^2 . This k^2 is the square of the radius of gyration of the solid prism 1 inch long.

From equation (1) of Article 150 we know that the square of the radius of gyration of a prism is equal to the sum of the squares of the radius of gyration as a thin section and the radius of gyration as a rod. In this case the square of the radius of gyration as a rod is one-twelfth of the square of the length.

PROBLEMS.

1. In the case of the unknown section of Fig. 195, III, and IV, the length l is 1 inch, the weight in air 1.524 pounds, the weight in water 1.326 pounds. The water was at the temperature at which the density is 62.2 pounds per cubic foot. What is the area of cross section? *Ans.* 5.50 square inches.
2. On a torsion pendulum with a light support the body in the position shown made 100 vibrations in 83.2 seconds. A rod $\frac{1}{4}$ inch in diameter and 12 inches long weighing 0.668 pound makes 100 vibrations in 163.8 seconds. What is the radius of gyration of the body and of its cross section? *Ans.* k of cross section is 1.127 inches.
3. In Problem 2 what is the moment of inertia of the cross section? *Ans.* 6.99 inches⁴.
4. The center of gravity of the section of Fig. 194, III, is 2.48 inches from A. What is the section modulus?

Lewis P. McGilvary
Elect. Eng. 1916

CHAPTER XIX.

REPEATED STRESSES.

156. **Lag of Deformation behind Stress.**— When force is applied to an elastic solid the deformation lags a little behind the stress. In the test of a rod in tension, if the machine is stopped with the beam balanced, after a short time it is found to be no longer in equilibrium. If the load is increasing when the machine is stopped, the beam drops, showing a continued elongation with a slightly diminished stress. If the stress is below the yield point, the beam drops slowly; if above the yield point, it comes down quickly. If a little more load is applied so as to raise the beam, it comes down more slowly the next time. In any case, an equilibrium can finally be found at which there is no change.

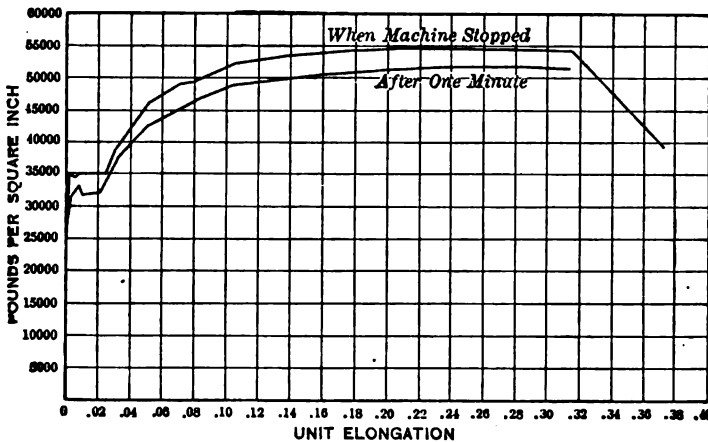

Fig. 197. — Effect of Time on Stress-strain Diagram.

As a result of this lag of deformation there is a considerable variation in the form of the stress-strain diagram of any material depending upon the rate of speed of the testing machine. If the machine runs rapidly the diagram will be higher than if it goes slowly. Frequently the machine is run at a rather high speed until a given load is reached and then stopped to read the extensometers. Table XII gives the results for a bar of soft steel

tested in this way. The poise was set at the load given in the first column and the rod was stretched till equilibrium was secured. It was then stopped for one minute, at the end of which time the poise was moved to get a new balance.

Fig. 197 is plotted from Table XII (together with some intermediate points omitted from the table). If the steel were tested by means of an autographic machine which draws the stress-strain diagram, the curve would be still higher than the upper one of the figure, depending upon the speed of the machine.

TABLE XII.
TEST OF SOFT STEEL IN TENSION.
Area of section, 0.600 square inch.

Total load.		Unit stress per square inch.		Elongation when machine stopped.	
When machine stopped.	After one minute.	When machine stopped.	After one minute.	In 8 inches.	Unit.
Pounds.	Pounds.	Pounds.	Pounds.	Inches.	Inch.
30	30	50	50	0	0
6,150	6,000	10,250	10,000	.0027	.00034
9,000	8,650	15,000	14,420	.00405	.00051
12,200	11,800	20,330	19,670	.0055	.00069
15,000	14,400	25,000	24,000	.00675	.00084
18,000	17,100	30,000	28,500	.0082	.00102
19,200	18,250	32,000	30,420	.0085	.00106
19,800	18,600	33,000	31,000	.0087	.00109
20,400	19,150	34,000	31,920	.0092	.00115
21,000	19,200	35,000	32,000	.0121	.00151
20,600	19,350	34,330	32,250	.0450	.00562
20,600	20,000	34,330	33,330	.0530	.00662
21,000	19,000	35,000	31,670	.0733	.00916
21,000	19,200	35,000	32,000	.1740	.02175
21,600	20,900	36,000	34,830	.2121	.02651
22,800	21,750	38,000	36,250	.2393	.02991
24,000	22,900	40,000	38,160	.2773	.03466
26,400	25,050	44,000	41,750	.3873	.04841
28,800	26,900	48,000	44,830	.5506	.06882
31,200	29,050	52,000	48,520	.83	.104
32,400	30,600	54,000	51,000	1.30	.162
32,800	30,850	54,670	51,420	1.62	.202
32,850	31,200	54,750	52,000	1.89	.236
32,750	30,950	54,580	51,580	2.08	.260
32,600	30,900	54,330	51,500	2.52	.315
23,400	39,000	2.98	.372

Broke at 23,400 pounds. The area of the neck was 0.196 square inch.

The static load which would produce a given deflection would come below the lower curve. The apparent ultimate strength of this steel is 54,750 pounds per square inch. The actual ultimate strength in terms of the original area is less than 52,000 pounds per square inch.

From this table and curve we see that in order to compare the results of tests of materials the speed of the test is an important factor. This is especially the case with very ductile materials. The modulus of elasticity taken rapidly is much larger than if taken slowly.

The form of the stress-strain diagram and the amount of lag of deformation depend somewhat upon the previous treatment of the material. A bar of hot-rolled steel when tested for the first time will generally show some permanent set at loads below the true elastic limit. If it is raised nearly to the yield point and then reduced to zero and again raised, the second test will show no set and will generally give a better curve than the first one. If steel or wrought iron is carried beyond the yield point and the load released, the second test will show a yield point above the previous maximum stress.

TABLE XIII.
SOFT STEEL BEYOND THE YIELD POINT.
Original area, 0.600 square inch.

Total load.		Unit stress per square inch.		Elongation when machine stopped.	
When machine stopped.	After one minute.	When machine stopped.	After one minute.	In 8 inches.	Unit.
Pounds.	Pounds.	Pounds.	Pounds.	Inch.	Inch.
23,400	39,000	— .0576
24,000	23,300	40,000	38,830	— .0441
24,600	23,500	41,000	39,170	— .0148
25,200	24,100	42,000	40,170	.01425	.00178
21,000	21,075	35,000	35,125	.01275	.00159
18,000	18,025	30,000	30,040	.0111	.00139
15,000	15,125	25,000	25,210	.0094	.00117
12,000	12,150	20,000	20,250	.00765	.00096
9,000	9,325	15,000	15,540	.00505	.00076
6,000	6,250	10,000	10,420	.00415	.00052
3,000	3,175	5,000	5,290	.0021	.00026
30	125	50	210	.0001
30	30	50	50	.0	.0
3,000	3,000	5,000	5,000	.00105	.00013
6,000	6,000	10,000	10,000	.0026	.00032

TABLE XIII (Continued).

Total load.		Unit stress per square inch.		Elongation when machine stopped.	
When machine stopped.	After one minute.	When machine stopped.	After one minute.	In 8 inches.	Unit.
Pounds.	Pounds.	Pounds.	Pounds.	Inch.	Inch.
9,000	8,900	15,000	14,830	.00435	.00054
12,000	11,900	20,000	19,830	.0061	.00076
15,000	14,950	25,000	24,920	.00785	.00098
18,000	17,825	30,000	29,710	.00965	.00121
21,000	20,900	35,000	34,830	.0116	.00145
24,000	23,600	40,000	39,330	.01355	.00169
24,600	24,200	41,000	40,330	.0154	.00192
25,200	24,550	42,000	40,920	.01765	.00221
24,000	23,900	40,000	39,830	.01735	.00217
21,000	21,150	35,000	35,250	.0158	.00197
18,000	18,100	30,000	30,170	.0142	.00177
15,000	15,075	25,000	25,125	.0123	.00154
12,000	12,225	20,000	20,375	.0108	.00135
9,000	9,300	15,000	15,500	.0090	.00112
6,000	6,225	10,000	10,375	.0073	.00091
3,000	3,125	5,000	5,210	.0052	.00065
30	120	50	200	.0035
30	30	50	50	.0033	.00041
Test bar rested 40 hours without load.					
30	30	50	50	.0033	.00041
3,000	2,970	5,000	4,950	.00455	.00057
6,000	6,000	10,000	10,000	.0059	.00074
9,000	8,900	15,000	14,830	.00745	.00093
12,000	11,850	20,000	19,750	.00895	.00112
15,000	14,825	25,000	24,710	.01035	.00129
18,000	17,850	30,000	29,750	.01185	.00148
21,000	20,800	35,000	34,670	.0134	.00167
24,000	23,850	40,000	39,750	.01505	.00188
21,000	21,000	35,000	35,000	.01365	.00171
18,000	18,100	30,000	30,170	.01215	.00152
15,000	15,100	25,000	25,170	.01075	.00134
12,000	12,100	20,000	20,170	.00925	.00116
9,000	9,050	15,000	15,080	.00785	.00098
6,000	6,175	10,000	10,290	.00635	.00079
3,000	3,175	5,000	5,290	.00475	.00059
30	30	50	50	.0033	.00041
3,000	3,000	5,000	5,000	.00445	.00056
6,000	5,950	10,000	9,920	.00575	.00072
9,000	8,850	15,000	14,750	.00735	.00092
12,000	11,850	20,000	19,750	.0089	.00111
15,000	14,900	25,000	24,830	.01045	.00131
18,000	17,600	30,000	29,330	.0119	.00149
24,000	23,800	40,000	39,670	.0151	.00189
24,600	24,500	41,000	40,830	.0155	.00194

TABLE XIII (Concluded).

Total load.		Unit stress per square inch.		Elongation when machine stopped.	
When machine stopped.	After one minute.	When machine stopped.	After one minute.	In 8 inches.	Unit.
Pounds.	Pounds.	Pounds.	Pounds.	Inch.	Inch.
25,200	42,00001585	.00198
25,800	25,400	43,000	42,330	.0162	.00202
26,400	26,150	44,000	43,580	.0169	.00212
27,000	26,500	45,000	44,170	.0174	.00217
27,600	26,500	46,000	44,170	.01865	.00233

The unit stress was calculated from the original area of 0.600 square inch. The actual area was 0.578 square inch. The actual length of the gauged portion was 8.3 inches at zero elongation as read.

Table XIII gives some of the results for a test piece from the same rod as Table XII. This test piece was loaded to 36,000 pounds per square inch, producing an elongation of about 0.3 inch in a gauged length of 8 inches. The zero of the extensometer corresponds to 0.3 inch total elongation.

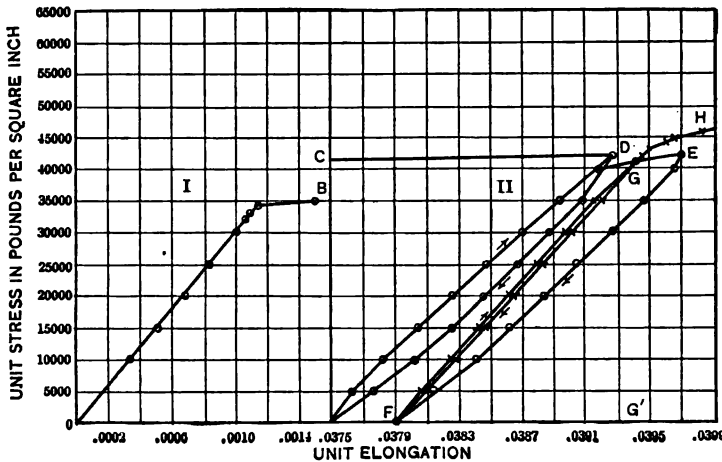

Fig. 198. — Stress-strain Cycles.

Curve I of Fig. 198 is plotted from Table XII. Curve II is plotted from Table XIII. The test of the piece used for Table XIII showed that the curve up to the yield point was practically the same as that of Table XII. The abscissas of curve II begin with 0.0375, which corresponds with the 0 of Table XIII.

After passing the point D on curve II we notice that the descending portion is concave toward the left. The same is true of the descending portion from E to F. All of these lines

are drawn from the readings at the time the machine stopped. If we were to draw the curve for the end of one minute rest, the descending portions from *D* and *E* would lie to the left of the curves as drawn and would be less concave. If we observe the table we notice that in going down from *D* the unit stress with a given elongation *increases* after a short rest. The maximum increase occurs at the unit stress of 9000 pounds. When soft steel is stretched it returns slowly to its original length after the load is removed. The deformation lags behind the stress in both the ascending and descending portions.

In coming from *C* to *D*, the maximum load at stopping the machine was 42,000 pounds per square inch, but the maximum load after one minute was only 40,170. We notice that the curve coming up from zero load is practically straight (except at the lower end) until 40,000 pounds is reached, where its slope drops suddenly. There is a considerable *permanent* deformation in passing from 40,000 to 42,000 pounds at *E*. While the curve has the same ordinates at *D* and *E* the permanent stress is 750 pounds greater at *E*. Below the 35,000-pound ordinate the descending curves from *D* and *E* are the same.

The ascending curve is nearly straight up to 40,000 pounds while the original yield point was less than 35,000 pounds. This is an illustration of the fact, mentioned in Article 25, that stress beyond the yield point raises the yield point of soft steel. The new yield point is found at the *permanent* unit stress which was previously reached.

From *F* to *G* and back to *F* is the cycle after 40 hours' rest without load. These curves are more nearly straight than the others. The descending and ascending portions are close together, and the lag, as shown from the tables, is smaller. The descending curve returns to zero, showing that the true elastic limit is not necessarily the limit of zero set. A stress-strain diagram may be considerably curved and the material show no *permanent* set.

Ascending from *F* to *G* the second time the curves coincide. The effect of the rest is shown by the fact that the curve from *G* to *H* lies considerably above the original curve to *E*.

The ascending portion of the first curve has a less slope than the similar curve after rest, showing the effect of rest in raising the modulus of elasticity. The curve *FG* has a slightly smaller

slope than curve I, showing an apparent decrease in the modulus due to overstraining. The unit stresses for curve II are computed from the original area of 0.600 square inch, while the actual area at the new zero elongation was 0.578 square inch. Also the unit elongations are computed from the original length of 8 inches. If we use the actual area in computing the stress and the actual length of 8.3 inches in calculating the unit deformations the modulus is practically the same for curve I and for curve II from F .

PROBLEMS.

1. From Table XII calculate E for at least three readings.
2. From Table XIII calculate E for at least two readings beginning with the initial load, and for two readings beginning with 3000 pounds, with the actual area and original length.

157. Watertown Arsenal Tests of Eyebars. — An interesting set of tests illustrating the behavior of steel and wrought iron

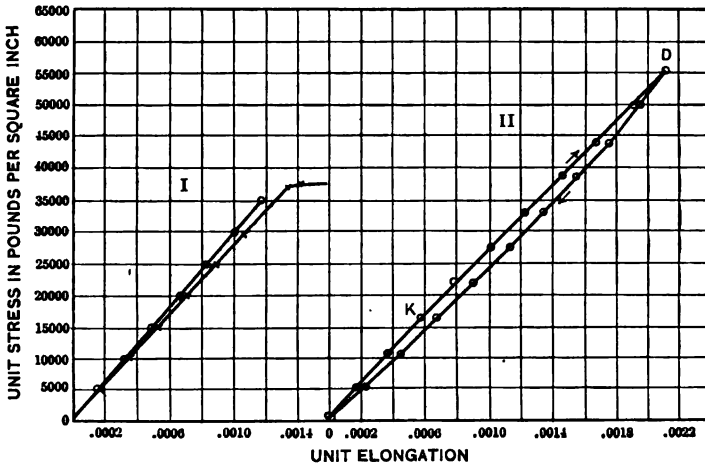

Fig. 199.

was made at the Watertown Arsenal in 1886 (Tests of Metals, 1886, Part 2, pp. 1571-1617). These tests were made on eyebars about 25 feet long. The gauged length was 260 inches, enabling the unit deformation to be read with great accuracy. Table XIV gives some of the results for the first loading of test piece No. 4136 (p. 1578). The initial load (as is customary in the Watertown tests) was 1000 pounds per square inch. After

each load the machine was reversed to the initial load to get the permanent elongation which is given in the table as "Set under

TABLE XIV.
WATERTOWN TESTS OF STEEL EYEBAR.

Total load.	Unit stress per square inch.	Elongation.		Set under initial load.	Net unit elongation.	E
		In 260 inches.	Unit.			
Pounds.	Pounds.	Inches.	Inch.	Inches.	Inch.	
5,250	1,000	0	0			
26,250	5,000	.0456	.000175	.0065	.000150	26,670,000
52,500	10,000	.0915	.000352	.0085	.000319	28,210,000
78,750	15,000	.1369	.000526	.0089	.000485	28,860,000
105,000	20,000	.1815	.000698	.0096	.000661	28,750,000
131,250	25,000	.2264	.000871	.0101	.000832	28,850,000
157,500	30,000	.2720	.001046	.0109	.001004	28,880,000
183,750	35,000	.3194	.001229	.0147	.001172	29,010,000
196,000	37,330	.3459	.001330			
198,000	37,710	.3700	.001423			
200,000	38,090	.5665	.002179			
204,750	39,000	1.07	.0041			
210,000	40,000	2.35	.0090			
369,000	70,286	30.42		

The bar was again tested to a total load of 262,500 pounds, or 50,000 pounds per square inch in terms of the original area. After this load the set was negative, and equal to 10 divisions. After a further rest of one hour at the initial load the reading was -0.0150 inch.

The micrometer was reset to zero and the bar was again loaded to 262,250 pounds. The elongation under this load was 0.6263 inch in the original length of 260 inches. The immediate set was 0.0028 inch. After 10 minutes the set was 0.0005 inch, and after 12 minutes it was zero.

The micrometer was reset to zero and the bar was tested the fourth time to a load of 341,250 pounds and back at intervals of 5000 pounds per square inch in terms of the original area. The elongation was 0.8660 inch. The immediate set was 0.0301 inch. After 20 minutes the set was 0.0215 inch.

The micrometer was reset and the bar was tested to 262,500 pounds. The elongation in the gauged length was 0.6257 inch. The immediate set was 0.0041 inch and the set after 6 minutes was 0.

The micrometer was reset to zero and the bar again tested to 262,500 pounds. At each load the elongation was taken immediately and again after an interval of 3 minutes. The results are given in Table XV, which shows the change in deformation with constant stress, while Tables XII and XIII show the change in stress at nearly constant elongation. In computing the unit stresses for this table the permanent area at the end of the first test is used instead of the original area. This permanent area is given as 4.70 square inches. Also in computing the unit elongations the length is taken as 290.4 inches.

REPEATED STRESSES

TABLE XV.

WATERTOWN TEST OF STEEL EYEBAR.

Area, 4.70 square inches. Gauged length 290.4 inches.

Bar previously stretched from 260 inches by a load of 369,000 pounds.

Total load.	Unit stress per square inch.	Elongation in 290.4 inches.		Immediate unit elongation.
		Immediate.	After 3 minutes.	
Pounds.	Pounds.	Inch.	Inch.	Inch.
5,250	1,117	0		
26,250	5,585	.0503	.0504	.000173
52,500	11,170	.1093	.1099	.000376
78,750	16,755	.1685	.1690	.000582
105,000	22,340	.2299	.2309	.000792
131,250	27,925	.2922	.2935	.001006
157,500	33,510	.3562	.3575	.001226
183,750	39,095	.4209	.4222	.001449
210,000	44,680	.4868	.4885	.001676
236,250	50,265	.5533	.5549	.001905
262,500	55,850	.6209	.6230	.002148
236,250	50,265	.5660	.5659	.001949
210,000	44,680	.5082	.5080	.001750
183,750	39,095	.4491	.4489	.001546
157,500	33,510	.3886	.3880	.001338
131,250	27,925	.3262	.3252	.001123
105,000	22,340	.2631	.2620	.000906
78,750	16,755	.1980	.1971	.000682
52,500	11,170	.1331	.1319	.000455
26,250	5,585	.0655	.0627	.000225
5,250	1,117	.0048	.0030	.000016
Bar rested 15 hours under initial load.				
5,250	-.0054		
5,250	1,117	0	(Micrometer reset to 0)	
26,250	5,585	.0504000173
52,500	11,170	.1084000373
78,750	16,755	.1660000572
105,000	22,340	.2250000775
131,250	27,925	.2870000988
157,500	33,510	.3510001209
183,750	39,095	.4157001431
210,000	44,680	.4839001666
236,250	50,265	.5493001891
262,500	55,850	.6180002128
236,250	50,265	.5621001935
210,000	44,680	.5047001739
183,750	39,095	.4459001535
157,500	33,510	.3857001328
131,250	27,395	.3241001082

TABLE XV (Continued).

Total load.	Unit stress per square inch.	Elongation in 290.4 inches.	Unit elongation.
Pounds.	Pounds.	Inch.	Inch.
105,000	22,340	.2609	.000898
78,750	16,755	.1973	.000679
52,500	11,170	.1321	.000455
26,250	5,585	.0644	.000222
5,250	1,117	.0065	.000023

initial load." To get the net elongation we subtract this set from the total elongation before dividing by the original length. The results are given graphically by curve I of Fig. 199. The net unit elongations are represented by the circles and the gross unit elongations by the crosses.

Curve II of Fig. 199 represents the first portion of Table XV. The curve is plotted from the immediate unit elongation. The curve is practically straight from *K* to *D*. (*D* is considerably below the maximum stress of Table XIV.) From *O* to *K* the curve is nearly a straight line. A consideration of the table shows that the bar continued to stretch at a constant stress when the load was ascending and shortened under a constant stress on the descending curve. The greatest difference in 3 minutes in the descending portion occurred at the apparent unit stress of 5000 pounds. The effect of the lag in deformation is further shown by the fact that the zero fell 0.0102 inch in 15 hours of rest.

PROBLEMS.

1. From the curve of unit stress and net unit elongation of Fig. 198, I, determine the modulus of elasticity of this steel.
2. Plot the stress-strain diagram from the second part of Table XV which gives the results after 15 hours rest. Calculate E .
3. Using the original area and the original length calculate E from the last part of Table XV.

158. Failure under Repeated Stress.— There is a considerable area between the ascending and descending portions of the stress-strain diagram in Figs. 198 and 199. The greater the limits of stress the greater this area. This inclosed area is a measure of the work expended in stretching the bar which is not recovered as mechanical work when the load is released.

This energy is lost as mechanical energy, being transformed into heat or expended in changing the molecular condition of the material.

PROBLEMS.

1. From the readings of Table XIII find the lost energy in a portion of the bar one inch in length in passing through the cycle from *F* to *G* and back to *F* (Fig. 198, II). *Ans.* 0.8 inch pound.

2. From Table XV find the total energy expended in the entire gauged length during one cycle. Also solve after 15 hours' rest.

Since energy is lost in a cycle of this kind it is natural to expect that a great number of repetitions of stress would cause failure at a maximum stress less than the ultimate strength of the material. The experiments of Wöhler and others show that this is the case.*

When the stress varied from zero to a maximum it was found that if this maximum was less than one-half the ultimate strength the piece would fail under a great number of repetitions of load. If a steel bar having an ultimate strength of 60,000 pounds per square inch is loaded from 0 to 40,000 pounds it will probably break after a few thousand applications. If loaded from 0 to 35,000 it will last much longer. If from 0 to 30,000 it *may* fail after several million repetitions. If loaded from 0 to 25,000 it will last indefinitely.†

When the stress does not return entirely to zero the area of the figure representing the lost energy is less. The experiments with repeated stresses show that the maximum stress can be greater without failure under an indefinite number of repetitions. Steel having an ultimate strength of 60,000 pounds per square inch will stand a stress varying from 25,000 to 40,000 pounds, or from 20,000 to 35,000 without failure.

If the stress changes from compression to tension the maximum is less than for the case of one kind of stress only. Experi-

* See Goodman's "Mechanics Applied to Engineering," under the head "Wöhler's Experiments." Unwin's "The Testing of Materials of Construction," pages 356-394, gives an excellent discussion of this subject. Also see paper by Henry B. Seaman, Transactions of the American Society of Civil Engineers, Vol. XLVI (1899), pages 141 to 150, and discussion on pages 166 to 257.

† See paper by J. H. Smith entitled "Some Experiments on Fatigue of Metals." The Journal of the Iron and Steel Institute, 1910, Vol. II, pp. 246-318.

ments show that when a bar is tested in one direction its elastic limit in the other is lowered, so that the raising of the elastic limit which occurs when a bar of ductile material is overstrained in one direction is lost when the reverse stress is applied. The experiments of Wöhler show that steel having an ultimate strength of 60,000 pounds per square inch when tested in tension will fail under a stress which changes from 16,000 compression to 16,000 pounds tension. If the stress changes from 14,000 tension to 14,000 compression the piece will probably stand an indefinite number of repetitions.

159. Design for Varying Stresses. — A number of methods have been proposed for designing members subjected to repeated stresses. This may be done by lowering the allowable unit stress or adding a suitable increment to the applied load.

The formula of Launhardt is an empirical formula based on Wöhler's experiments, which until recently was considerably used for calculating the allowable working stress for varying loads. This formula contains a factor depending upon the ratio of the ultimate static strength to the ultimate repetition strength when the load varies from 0 to the maximum. If we take this ratio as 2 which coincides reasonably well with the results of the tests, the formula may be written

$$s_v = \frac{s_w}{2} \left(1 + \frac{\text{minimum load}}{\text{maximum load}} \right),$$

where

s_w = static allowable unit stress,

s_v = maximum allowable unit stress with varying load.

When the minimum load is 0, $s_v = \frac{s_w}{2}$.

When the minimum load equals the maximum load, $s_v = s_w$.

PROBLEMS.

1. If the allowable unit stress for a given steel for a static load is 15,000 pounds per square inch, what is the maximum allowable unit load and the required area of cross section when the load varies from 20,000 to 30,000?

Ans. 12,500 pounds per square inch, 2.4 square inches.

2. Find the area of cross section to carry safely a load which varies from 120,000 to 360,000 pounds if the allowable static unit stress is 15,000 pounds per square inch.

Ans. 36 square inches.

Launhardt's Formula applies to stresses in one direction only. Goodman * recommends a simple rule which is easy to remember and convenient to apply. *Add to the maximum load the difference between the maximum and minimum load and treat the sum as a static load.*

PROBLEMS.

3. Solve Problem 1 by Goodman's "dynamic" rule.
Ans. 2.67 square inches.
4. What is the cross section required to carry a load which varies from 30,000 pounds compression to 60,000 pounds tension if the allowable static unit stress is 12,000 pounds per square inch?
Ans. 12.5 square inches.
5. A shaft is supported between bearings 4 feet apart and carries a load of 600 pounds at the middle. If the allowable static unit stress is 12,000 pounds, what is the minimum diameter of the shaft to allow for the alternate tension and compression as the shaft rolls over?
 If the shaft makes 100 revolutions per minute in what time will the stress reverse one million times?

160. Impact Stresses. — In order to determine the magnitude of the stress due to a given load it is necessary to know how the load is applied.

Loads which are fixed in position and constant in magnitude are *dead loads*. The weight of a structure is a dead load. A load which is applied gradually, as the weight of falling snow, is treated as a dead load. A load which varies in position, such as the weight of a moving train on a bridge, is a *live load*. Any load which changes in position or magnitude will produce *impact stresses*. The magnitude of this impact factor depends upon the speed of application.

Fig. 200, I, represents a suspended spring. In II a load is attached to the spring but supported by *B* so that it exerts no pull on the spring. In III the support *B* is lowered gradually; a part of the weight *W* is carried by *B* and the remainder by the spring *S*. In IV the spring supports the entire weight. The upward pull exerted by the spring is equal to the weight. If *P* is the pull required to stretch the spring unit distance, the total pull in position IV is $P y_1$ where y_1 is the total elongation. If the support *B* is lowered gradually so that the average value of

* Goodman's "Mechanics Applied to Engineering," page 535. For a discussion of the various formulas see Johnson's "Materials of Construction," Article 389.

the sum of the pull of the spring and the reaction of the support is equal to W , the body will come to rest without vibration.

$$Py_1 = W,$$

$$y_1 = \frac{W}{P}.$$

The energy stored in the spring is $\frac{Py_1^2}{2}$, which is only one-half of the work of gravity on the mass W . The remaining half of the energy is expended on the support B which moves a distance y with an average push of $\frac{Py_1}{2}$.

If the support B is suddenly removed from W in the position II, the entire force of gravity is effective throughout the whole distance. At first the spring offers no resistance and the entire load goes to accelerate the mass (provided the mass of the spring is negligible). As it is stretched, the resistance of the spring increases. At the position IV the pull of the spring is equal to the weight and the acceleration is zero. The mass has its highest velocity at the point where it would come to rest under a gradually applied load. Beyond this point, represented by IV, the upward pull of the spring is greater than the weight and the body is negatively accelerated. It finally stops at the position of Fig. 200, V, with an elongation of the spring y_2 . To calculate this elongation, we have

$$Wy_2 = \frac{Py_2^2}{2},$$

$$y_2 = \frac{2W}{P} = 2y_1,$$

$$Py_2 = 2W.$$

The deflection due to a suddenly applied load is twice as great as when the load is gradually applied, and the maximum force is twice the load. After reaching the maximum elongation the body vibrates back to its original starting point (provided the spring is perfectly elastic).

Fig. 200, VI, shows the mass W lifted a distance h above the position of II, in which it exerts no pull on the spring. If released suddenly, it falls this distance before it begins to stretch the

spring. The total work done by gravity is the weight multiplied by the total distance $h + y$. At the lowest position VII this work has been transformed to energy of the spring.

$$W(h + y) = \frac{Py^2}{2}.$$

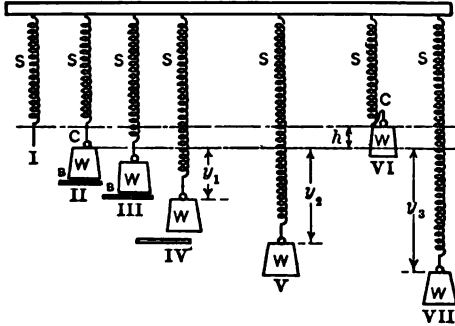

Fig. 200. — Effect of Sudden Loads and Impact.

PROBLEMS.

1. A force of 6 pounds stretches a given spring 1 foot. A 4-pound mass is placed on the spring and gradually lowered. What is the elongation of the spring when it comes to rest? *Ans.* 8 inches.
2. In Problem 1 the load is applied suddenly. What is the elongation of the spring and the maximum pull? *Ans.* 16 inches; 8 pounds.
3. In Problem 1 the load is lifted 1 foot and then released suddenly. How much does it stretch the spring, and what is the maximum tension? *Ans.* 2 feet; 12 pounds.
4. A springboard is made of a plank 12 inches wide and 2 inches thick as a cantilever 10 feet long. What is the maximum fiber stress when a boy weighing 60 pounds steps on it suddenly from a point at the same level as the end? *Ans.* 1800 pounds per square inch.
5. What is the maximum fiber stress in Problem 4, if the boy jumps down from a point 6 inches above the end of the plank, if the modulus of the timber is 1,200,000? *Ans.* 5545 pounds per square inch.

In most cases a varying load requires some time for its application, so that the stress produced by a live load is something less than twice that of an equal static load. When a locomotive runs on a bridge, the effective stress produced may be 50 per cent greater than that due to its weight alone. We say then that an impact factor of 50 per cent should be added to the live-load stress. If the speed is reduced, the impact factor is smaller.

For the impact factor which should be added to the live-load stress in the case of bridges, consult the specifications of the American Railway Engineering and Maintenance of Way Association.*

* The formula used is an empirical one based on experiments. For a description of the experiments upon which the formula is based, see the paper of F. E. Turneaure in the Transactions of the American Society of Civil Engineers, Vol. XLI, pages 410-466.

Lewis P. McGilvary

Elect. Eng. 1916

INDEX.

- A.
- Actual unit stress, 24.
Allowable unit stress, 4, 5.
American Railway Engineering and Maintenance of Way Association:
allowable stress, 5.
column formula, 208-211.
impact rule, 290.
American Society of Civil Engineers:
reference to transactions, 197, 199, 285, 290.
American Society for Testing Materials:
reference to transactions, 23, 32.
Apparent elastic limit, 21.
Apparent unit stress, 24.
Approximate computations, 161, 268, 269, 270.
Axes, principal, 177, 178, 263.
Axis, neutral, 85, 89, 90, 162.
- B.
- Beams, 66-168.
cantilever, 66, 104 *et seq.*
cast-iron, 158-162.
constant moment, 100, 102-104, 114-116.
constant strength, 153-158.
continuous, 66, 128-135.
counterflexure in, 124-128.
dangerous section, 83.
deflection, 99-138, 156-158.
deformation, 86.
differential equation, 101-102.
distribution of stress, 93-96.
external moment, 69.
failure of, 150, 151, 168, 219, 220.
modulus of rupture, 96-98.
- Beams, modulus of section, 91-94.
moment diagrams, 77 *et seq.*
points of inflection, 124-128.
radius of curvature, 99.
reinforced concrete, 151, 164-168.
resilience of, 231-235.
shear diagrams, 74-77, 80.
shear in, 68, 132, 139-150.
stiffness of, 117, 118.
stresses in, 67, 85, 87-96.
Bearing stress, 3, 49-51, 55-57, 154.
Breaking strength, 22.
Building laws, 5, 92, 210, 216.
butt joint, 58.
- C.
- Cambria Steel handbook, 4, 5, 23, 91, 93, 143, 217, 222, 249, 250, 258.
Cantilevers, 66, 104 *et seq.*
constant strength, 153-156.
deflection of, 104-108, 156-158.
supported at end, 119, 121.
Cast iron:
beams, 158-162.
stress-strain diagrams, 25, 160.
test, data of, 27.
Center of gravity, 239-250, 270-271.
by experiment, 270-271.
by moments, 240-243.
of continuous bodies, 243-245.
of plane areas, 245-250.
Cold-rolled steel, 34-36.
test data, 35.
Columns, 180-222.
American railway formula, 208.
classification of, 193, 194.
curves for, 188, 203, 209, 215.
definition, 180.
differential equation, 182.

- Columns, end conditions, 195-201.
 Euler's formula, 189-192, 218.
 Pencoyd tests, 197, 199-201.
 Rankine's formula, 212-217.
 Ritter's constant, 213, 214.
 Secant formula, 183-188.
 straight-line formulas, 202-211.
 theory, 181 *et seq.*
 Watertown tests, 207.
- Compression, 2, 48-50.
- Compressive stress, 3, 161.
 caused by shear, 43, 44, 144-150.
- Concrete, 29, 30, 48.
 reinforced, 151, 164-168.
 stress-strain diagram, 29.
 test data, 30.
- Counterflexure, 124-128, 194.
- Cover plates, 59.
- D.
- Dangerous section, 83.
- Deflection in beams, 99-138, 156-158.
 cantilevers, 104-108.
 constant strength, 156-158.
 fixed at ends, 119-128.
 supported at ends, 108-116.
- Deflection in columns, 183.
- Deformation, 5, 6, 39.
 lag behind stress, 275.
 of beams, 86.
 shearing, 39.
 unit, 5, 6, 225.
- Density of materials, 4.
- Department of Agriculture, 4, 32.
 timber tests, 5, 143.
- E.
- Eccentric loads, 170-179.
- Efficiency of riveted joint, 63.
- Elasticity:
 modulus, 7.
 shearing modulus, 39.
- Elastic limit, 6, 18.
 Johnson's apparent, 21.
 proportional, 20.
 true, 18-20.
- Elastic line, 104.
- Elongation, 15.
 per cent, 23.
Engineering News, 208, 210.
- Euler's formula, 189-192 *et seq.*
 curves for, 188, 203.
 derivation, 190.
 limits to use, 191, 218.
 relation to Rankine's formula, 213.
 relation to straight line, 202-205.
- Experimental tables, 17, 27, 28, 30,
 35, 200, 207, 276, 277, 282, 283.
- Eyebar tests, 282-284.
- F.
- Factor of safety, 29, 31.
 in columns, 189 *et seq.*
- Failure, 46-53.
 by cutting, 49-51.
 in beams, 150, 151, 168, 219.
 in compression, 48, 49, 50.
 of riveted joint, 60, 64.
 under repeated loads, 285.
- Fatigue, 285, 286.
- Fixed-end beams, 120-128.
- Fixed-end columns, 198.
- Flange failure, 219.
- Franklin Institute, 5.
- G.
- Graphic representation of stress distribution, 93-96.
- Goodman's impact rule, 287.
- Goodman's Mechanics, reference,
 285-287.
- Gyration, radius of, 253.
- H.
- Helical springs, 228-230.
- Hickory beams, 151, 152.
- Hinged-end columns, 195 *et seq.*
- Hooks, 174-176.
- Horizontal shear, 140-143.
- Horse power, 225.
- Hoskins' Mechanics, 172.

- I.
- Illinois, University of:
 timber tests, 21, 98, 143.
- Impact stress, 287-290.
- Infection, points of, 124-128.
- Intensity of stress, 3, 140.
- Internal work, 232.
- Iron and Steel Institute, reference, 285.
- J.
- Johnson's apparent elastic limit, 21.
- Johnson's "Materials of Construction," 16, 21, 287.
- L.
- Lap joint, 57.
- Launhardt's formula, 286.
- Limit, elastic, 6, 18.
- M.
- Maurer's Mechanics, 172.
- Modulus of elasticity, 7.
 calculation of, 21.
 in shear, 39, 46.
 of volume, 14.
- Modulus of resilience, 10.
- Modulus of rupture, 96-98.
- Modulus of section, 91-94.
- Moment, 69 *et seq.*
 diagrams, 77.
 due to eccentric loading, 172, 173.
 experimental illustrations of, 71-73.
 external, 69.
 general equation in beams, 122, 124.
 positive direction of, 70.
 relation to shear diagram, 79, 81-83.
 relation to stress, 87.
 resisting, 69, 166.
 resultant, 137.
- Moment of inertia, 251 *et seq.*
 axis for maximum, 262.
 by experiment, 272-274.
 change of direction of axis, 259.
 definition, 251.
 in thin plate, 255.
- Moment of inertia, of plane area, 257-274.
 polar, 257.
 principal, 138, 263.
 transfer of axis, 254.
- N.
- Neutral axis, 85.
 location of, 89-90, 161-162.
- Neutral surface, 85.
- New York building laws, 5, 92, 210, 211, 217, 222.
- Notation, xi-xii.
- P.
- Pencoyd column tests, 197-200.
- Philadelphia building laws, 216, 217, 222.
- Pin-end connections, 195 *et seq.*
- Poisson's ratio, 11.
- Polar moment of inertia, 257.
- Product of inertia, 260-262.
- Punching, 52.
- R.
- Radius of curvature, 99.
- Radius of gyration, 253.
- Railway Engineering and Maintenance of Way Association, 5, 208-211, 290.
- Rankine's formula, 212-217.
- Reduction of area, 23.
- Reinforced concrete, 151, 164-168.
- Repeated stress, 275-287.
- Resilience, 9, 10, 231-238.
 in beams, 234-238.
 modulus of, 10.
 sections for maximum, 237.
 torsion, 237.
- Ritter's constant, 213.
- Riveted joints, 54-65.
 butt joints, 58, 64.
 efficiency, 63.
 lap joints, 57.
 tests, 59-61.
- Round-end columns, 195 *et seq.*

S.

- Section modulus, 91.
- Shear, 37-47, 68, 74, 139-150.
 caused by tension, 41.
 deformation in, 39, 45.
 forces in pairs, 42, 43.
 in beams, 68, 74, 132, 139-150,
 154.
 maximum resultant, 145.
 modulus of elasticity, 39.
 stress caused by torque, 223.
- Shear diagrams, 74 *et seq.*
 relation of area to moment, 81,
 83.
- Shearing stress, 37.
 in beams, 69, 140, 144.
 in shafting, 223-225.
- Society of Civil Engineers, 197, 199,
 285, 290.
- Society for Testing Materials, 23,
 33.
- Specifications, Manufacturers', 23.
- Springs, 229, 234, 235, 289.
- Square-end columns, 198.
- Steel tests, 17, 35, 59-64, 276, 277,
 282.
 stress-strain diagrams, 18, 19, 275,
 279, 281.
- Stress, 2.
 allowable unit, 4.
 bearing, 3, 55-57.
 beyond elastic limit, 96.
 beyond yield point, 15, 33.
 compressive, 3.
 in beams, 67, 85 *et seq.*
 in riveted joints, 54.
 resultant, 144-150, 168.
 shearing, 37, 139-150, 224.
 tensile, 3.
 unit, 3, 88.
 working, 4.
- Stress-strain diagrams, 15.
 cast iron, 25, 160.
 concrete, 29.
 steel, 18, 19, 279, 281.
 yellow pine, 25, 29.

T.

Tables, calculated:

- VI. resultant stress in beams, 149.
 VII. eccentric loaded columns, 187.
 VIII. Euler's formula, 192.
 XI. computation of center of grav-
 ity, etc., 270.

Tables, experimental:

- I. machine steel, 17.
 II. cast iron, 27.
 III. yellow pine, 28.
 IV. concrete, 30.
 V. cold-rolled steel, 35.
 IX. Christie's column tests, 200.
 X. a wrought-iron column, 207.
 XII. soft steel, 276.
 XIII. soft steel, 277, 278.
 XIV. structural steel, 282.
 XV. structural steel, 283, 284.
- Tensile stress, 3.
 caused by shear, 43, 144, 168.
- Tension, 1, 12, 47, 55.
- Testing Materials, Society, 23, 32.
- Theorem of three moments, 128-135.
- Torque, 223-230.
 relation to angle of twist, 225, 226.
 relation to stress, 224, 225.
 relation to work, 227.
- Torsion, 223 *et seq.*
 combined with bending, 227, 228.
- Total stress, 2.

U.

- Ultimate strength, 22.
 effect of form on, 32, 33.
- Unit stress, 3.
 actual, 24.
 apparent, 24.
 in beams, 88.
- United States Department of Agri-
 culture, 4, 5, 32, 143.
- Unwin's "Testing of Materials," 285.

V.

- Volume change, 12.

W. .

Watertown Arsenal tests, 7, 13, 26,
28, 59-64, 159, 206, 230, 281.
Web failure, 220.
White oak, 48, 50.
White pine, 151, 152.
Wöhler's experiments, 285.
Working stress, 4.

Wrought iron, 49.

Wrought-iron columns, 200, 206.

Y.

Yellow pine, 3, 28, 47, 50, 152.
column formula, 211.
Yield point, 18-20, 23.
Young's modulus, 6.

89080442221



b89080442221a

SDH
B694
1911

252246